

Improve your skill level with these 1/72 Scale Books  
by AMMO of MIG JIMENEZ

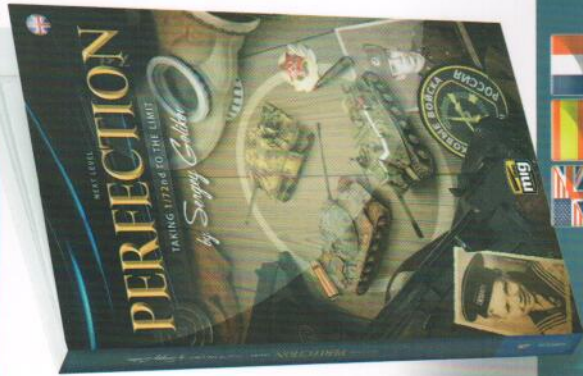

A.MIG-6122

NEXT LEVEL: PERFECTION -

Taking 1/72 scale to the next level

Sergey Golikov shows how to take these little models to the next level, a truly comprehensive guide to assembly, detailing, conversions, and the most realistic painting techniques suited to this scale. This book is ideal for any modeler wishing to improve and raise their skills to a professional standard.

A wide range of subjects and variables are covered including climatic and weather conditions, and theatres of conflict ranging from North Africa to Northern Europe.



A.MIG-6019

TWM SPECIAL - HOW TO PAINT 1:72 MILITARY VEHICLES

With this ground breaking book, AMMO enters the world of 1:72 scale modeling with authority. This book is the essential painting and weathering guide for 1:72 scale modelers. Beginning with a history of the scale, we will explore the many fascinating and refreshing aspects of modeling in this increasingly popular scale. Featuring a collection of the world's best modelers demonstrating the latest techniques, these pages are lush in technical detail, explaining in depth painting and weathering processes with numerous step by step examples including: scratchbuilding, assembly, camouflage painting, weathering, and the effects of dust and mud!



# T-54B

## INSTRUCTIONS GUIDE

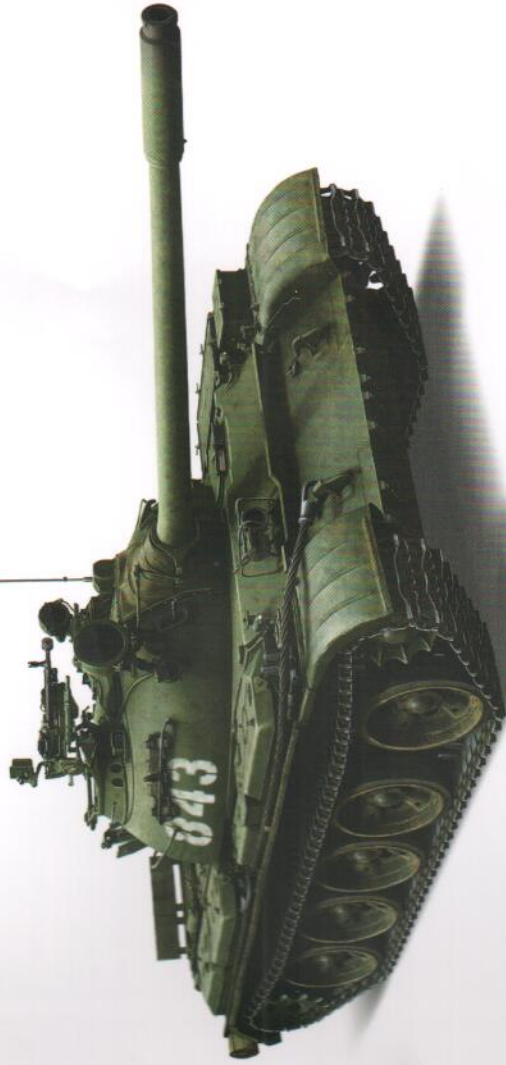

@AMMOMIG

www.migjimenez.com



# REFERENCE PHOTOS

## T-54 AMMO KIT

In your hands you hold the 1st independently designed AMMO by Mig Jimenez plastic model kit in 1:72 scale. For this momentous product release, we have chosen the world renowned Russian designed T-54B, an equally exciting subject. This universally admired battle tank has served scores of nations around the globe and endured more than a half century of conflict. Our professional vehicle research and access to running examples for measurements has resulted in a marvel of accuracy in this fine scale replica.

The thoroughly researched camouflage and markings guide included with this kit faithfully reproduce a host of attractive options. Because of the prolific service record of this vehicle, the choices of camouflage colors and markings are limited only by references and your imagination.

## T-54B SERVICE

Going into production in 1957, the T-54B was developed in 1955, and featured a new 100mm D-10T2S main gun fitted with the Tsyklon 2-axis stabilizer, which could fire specially developed APFSDS rounds to dramatically improve armor penetration.

The T-54B was the first Soviet tank to be fitted with night-fighting equipment, which consisted of the L-2 Luna infrared gun sight and OU-3 infrared searchlight for the commander. The T-54 successfully served the North Vietnamese in combat and made international headlines in 1972 during the Easter Offensive and once again in 1975 photographed crashing through the gates of the Presidential Palace in Saigon, signaling the end of Vietnam's civil war.

Variants of the T-54 saw action during the Hungarian Revolution in 1956, served Egypt and Syria during the Six-Day War of 1967, and were captured during the 1973 Yom Kippur war to be updated and serve as the Tiran-4. The tank was also heavily used by Iraq during the 8-year long Iran Iraq War of the 1980's, and several are currently serving in the Syrian Civil War in the Aleppo area.



The Vietnam war is very important to modelers, and has been a fountain of inspiration for me over the years. But it was after a recent trip to Saigon that I was able to gain a real sense of the country and her people, and I fell in love with Vietnam's military history. The T54 tank number 843 was the first tank to enter Saigon's Presidential Palace and is now a symbol of heroism and a national monument. Although the tank on display is not the original vehicle, it represents a similar model. I want to share this walk around with you to help you improve your own model. I sincerely hope that you enjoy this kit and share my passion for Vietnam, thank you.





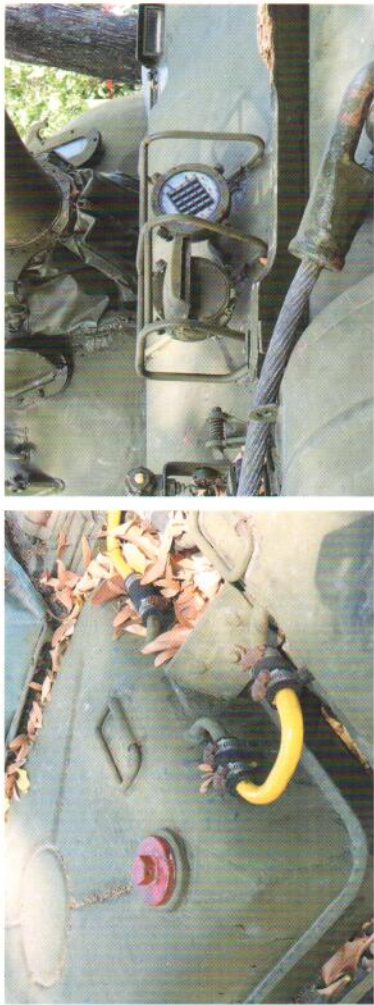



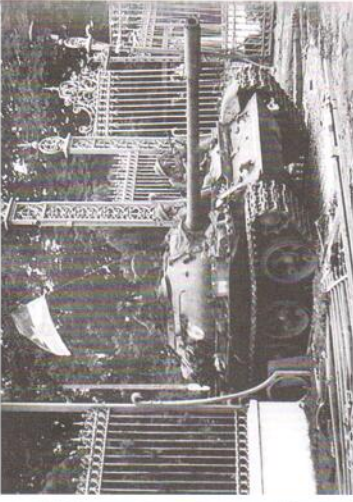
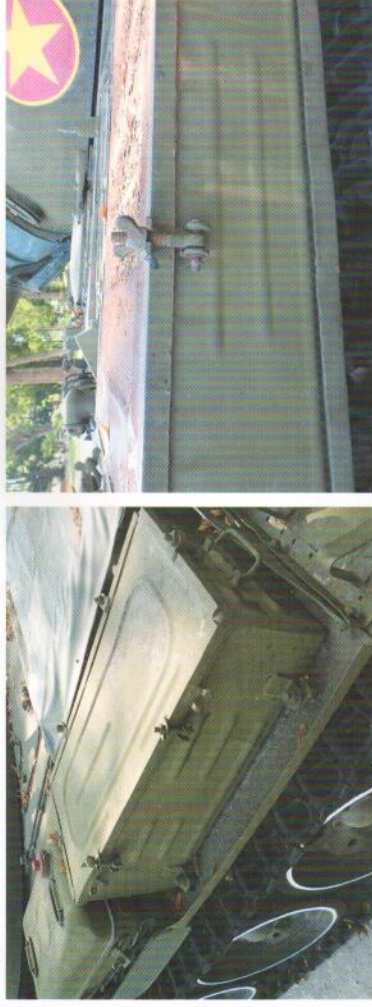



# PARTS

## READ THIS BEFORE YOU BEGINNING YOUR MODEL!

1. This scale model is intended for hobbyists 14 years and older.
2. Carefully read all instructions for this kit and suggested finishing and painting products (not included with this product) before you begin assembly of this scale model.
3. Adult supervision may be required when using hobby knives, abrasives, and any tools not included with this kit during assembly.
4. This kit includes small parts and plastic bags that can be a dangerous choking hazard. Keep out of reach of children.

### ICONS



## HOW TO ASSEMBLE THIS KIT

Carefully read the instructions for each step before beginning the assembly.

- Separate the kit pieces from the sprue using a blade while resting the sprue on a cutting board. Remove the remaining sprue with a fine file.
- Dry fit and test for proper alignment of pieces before applying Slow Dry Cyanoacrylate A.MIG-8013 which offers the necessary work time and accurate placement. We advise lightly sanding the contact surface of the parts to be joined to improve adhesion.
- Permanently join pieces with styrene glue Extra Thin Cement A.MIG-2025 or Medium Dense Cement A.MIG-2039.
- For the assembly of pieces that do not need rigid joints, or require some flexibility such as tool clamp supports and handles, we recommend using Ultra Fixer A.MIG-2031 to create joints more resilient to manipulation and handling during assembly.
- Apply corrective filler Putty A.MIG-2036 to level any gap or step between pieces. Let the putty dry and level the area with fine files and sandpaper.

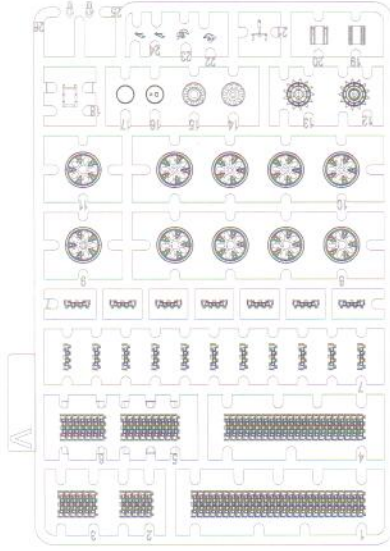
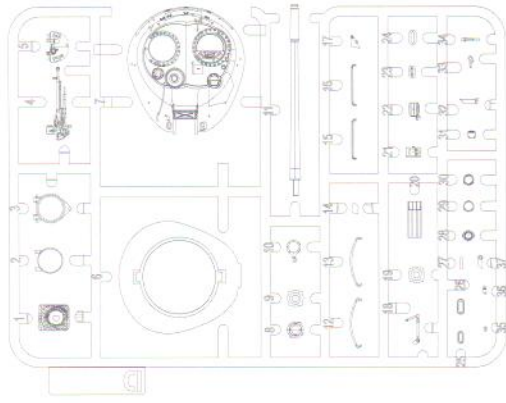

X2

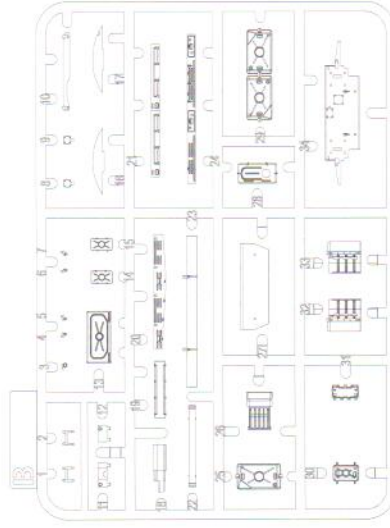
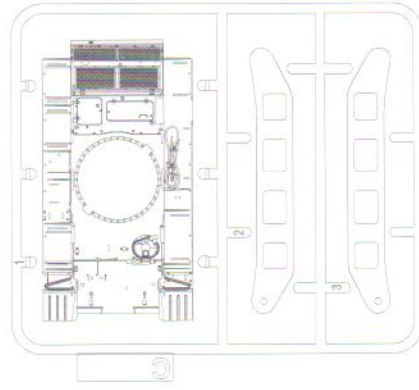

Cable

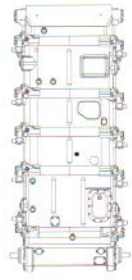

Lower Hull



TP

Decal



1

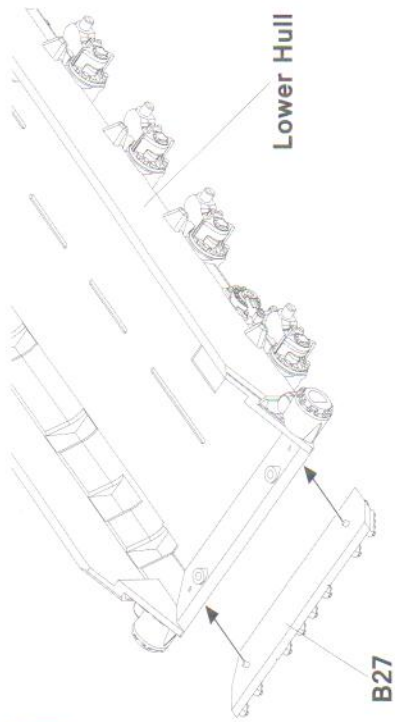

2

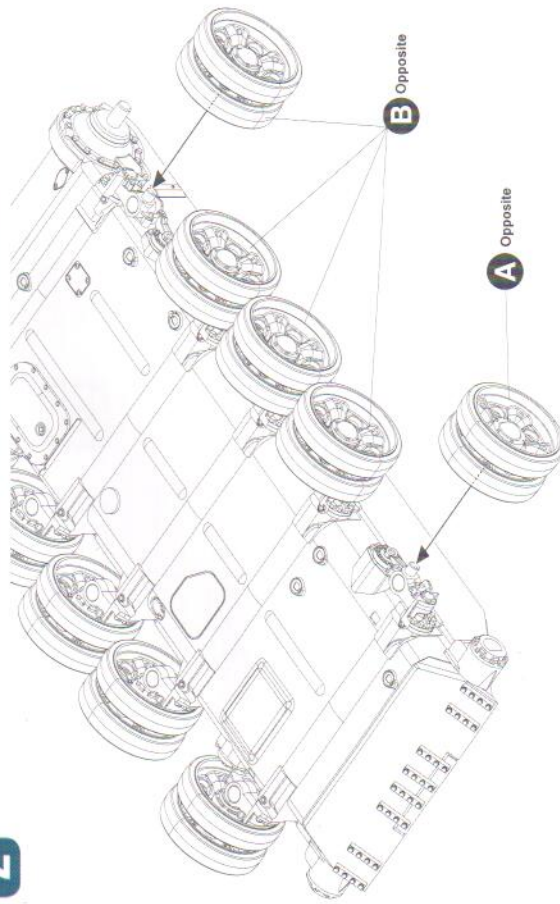

**Make 2**

**Make 8**

3

**Make 2**

**Make 2**

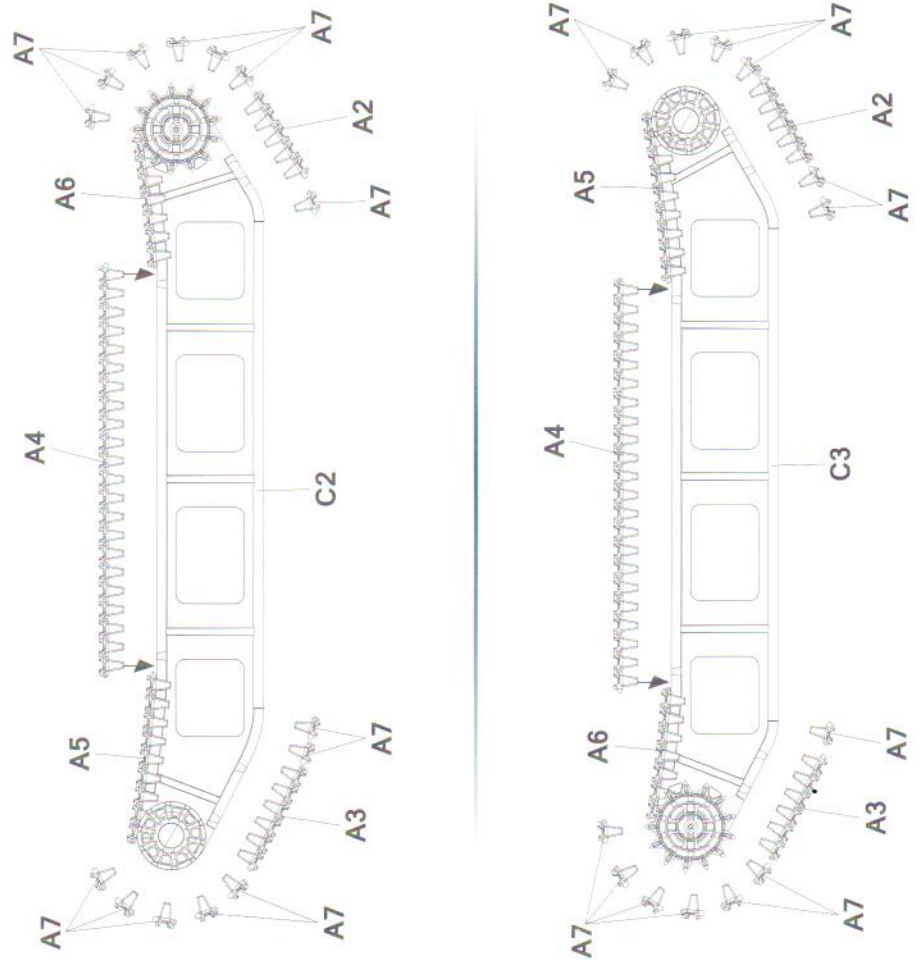



4

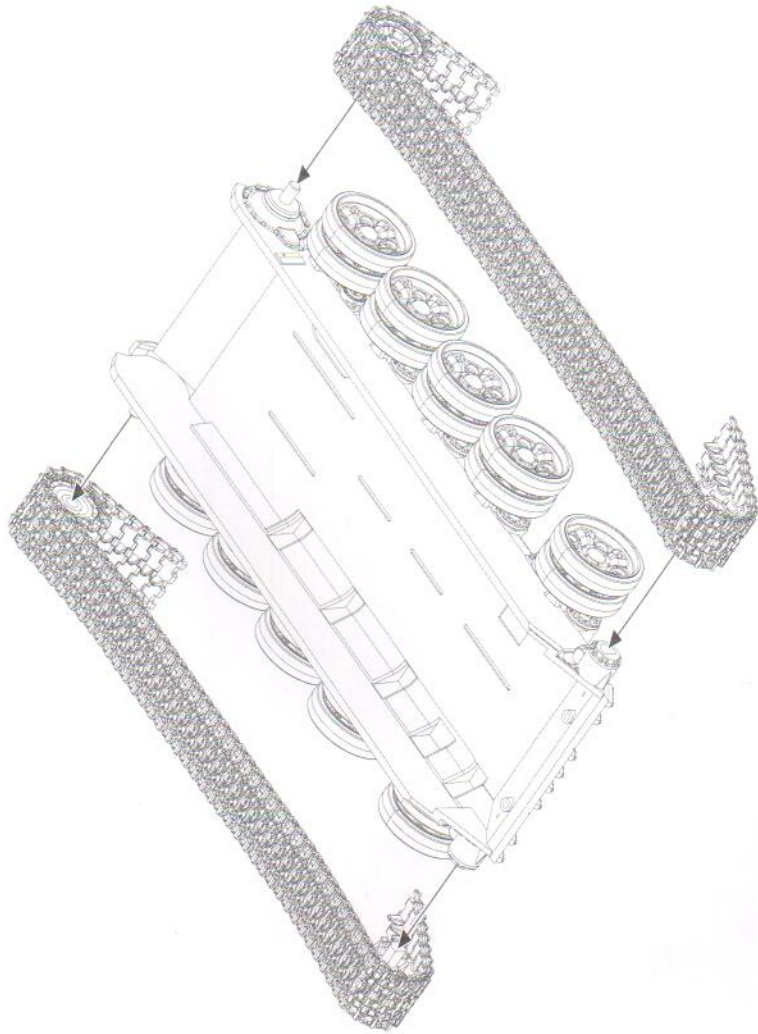

5

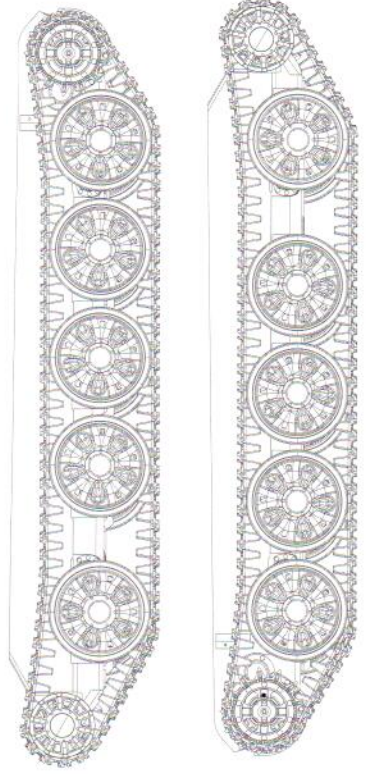
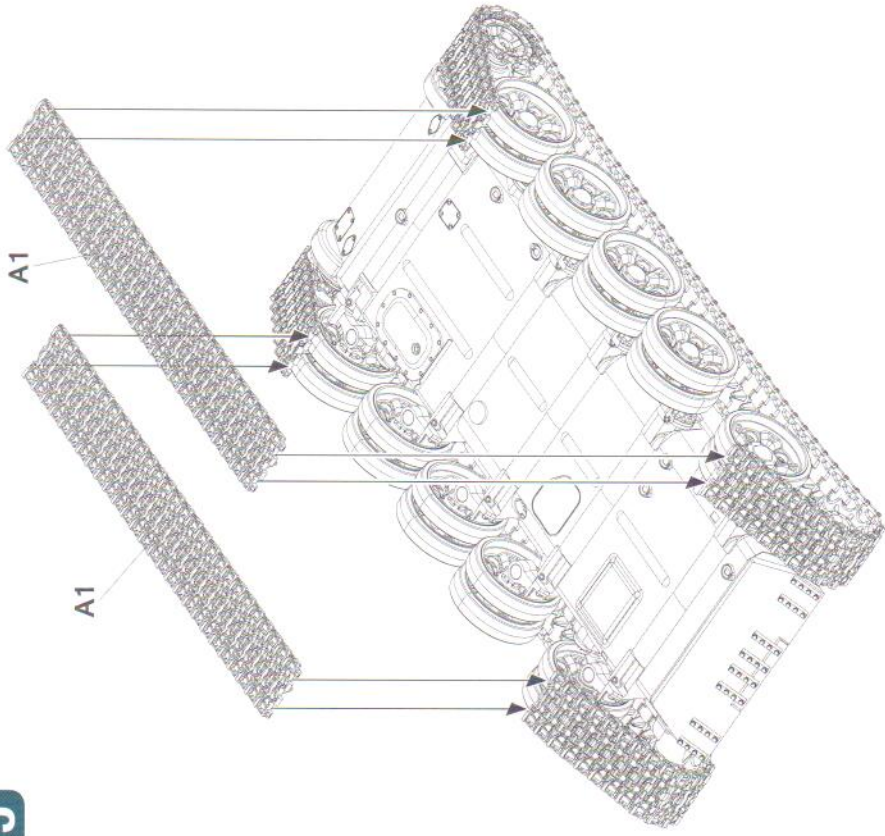

6

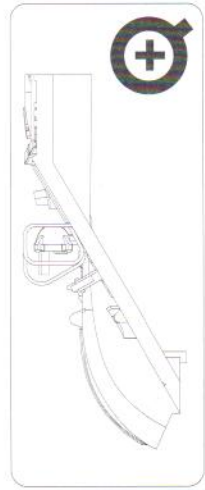
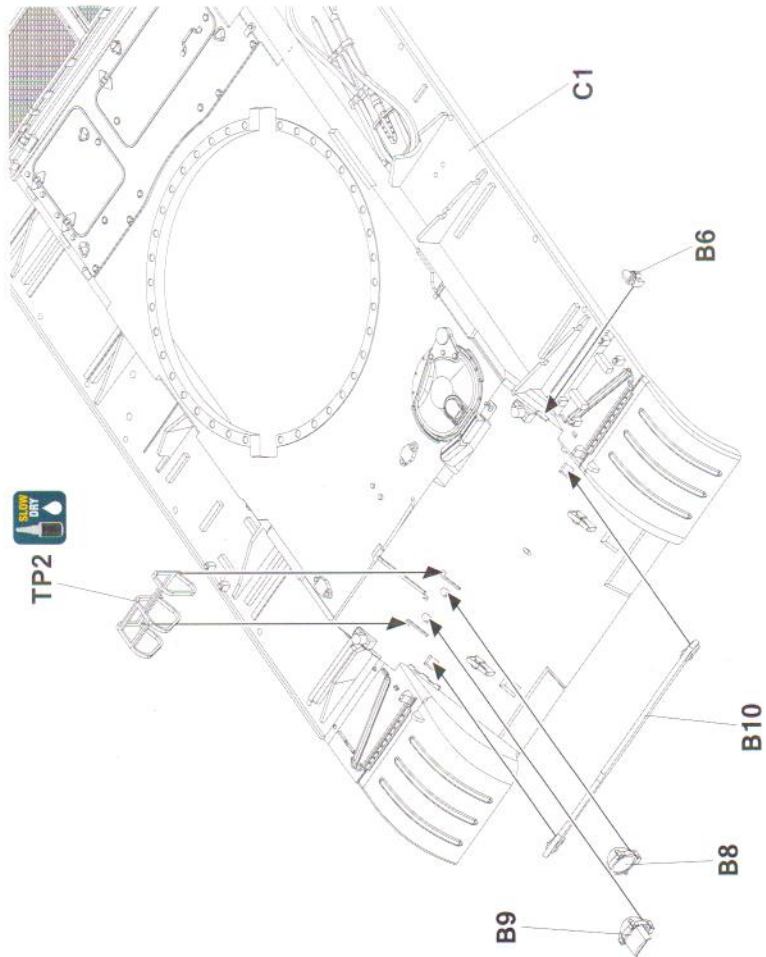

7

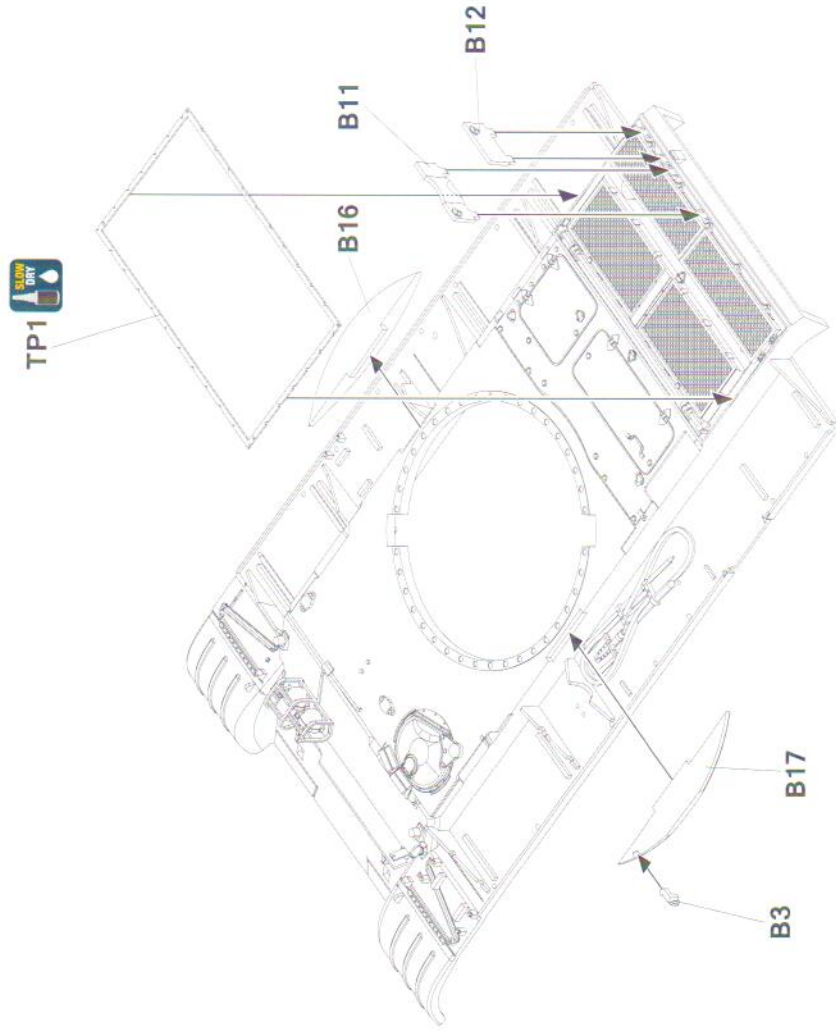



8

A

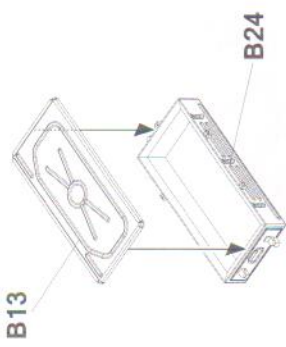

9

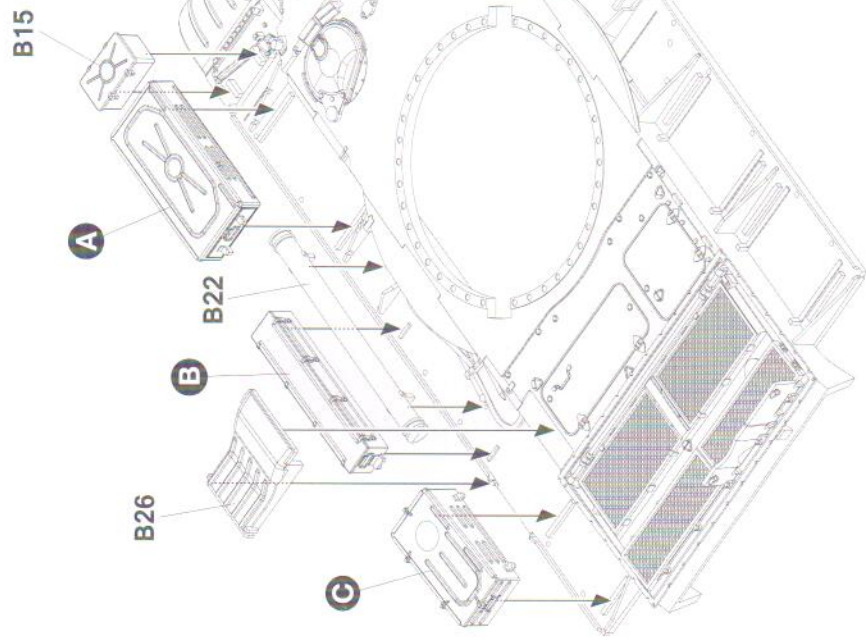

B

B21



B19

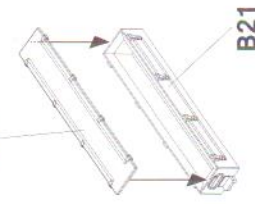

C

B20



B28

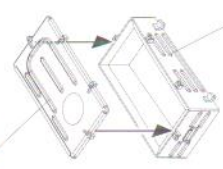

B21

B20



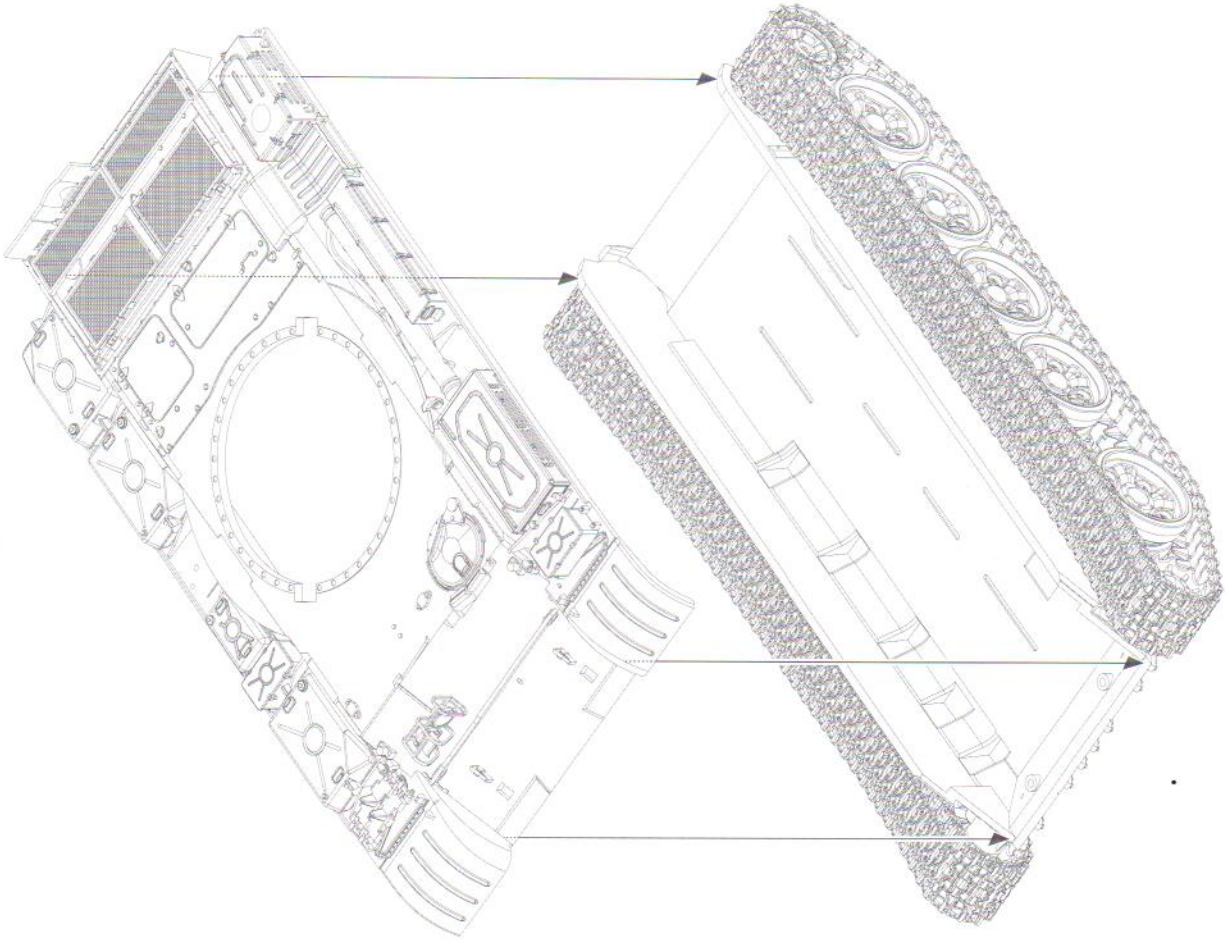
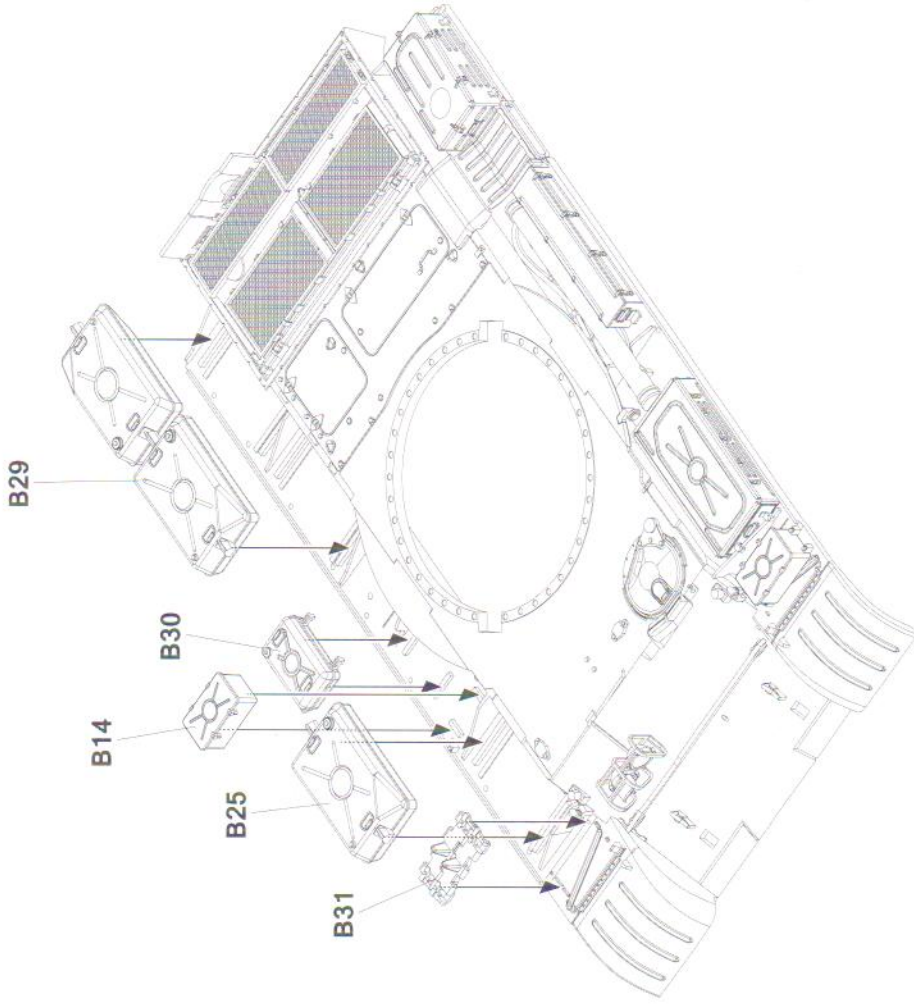



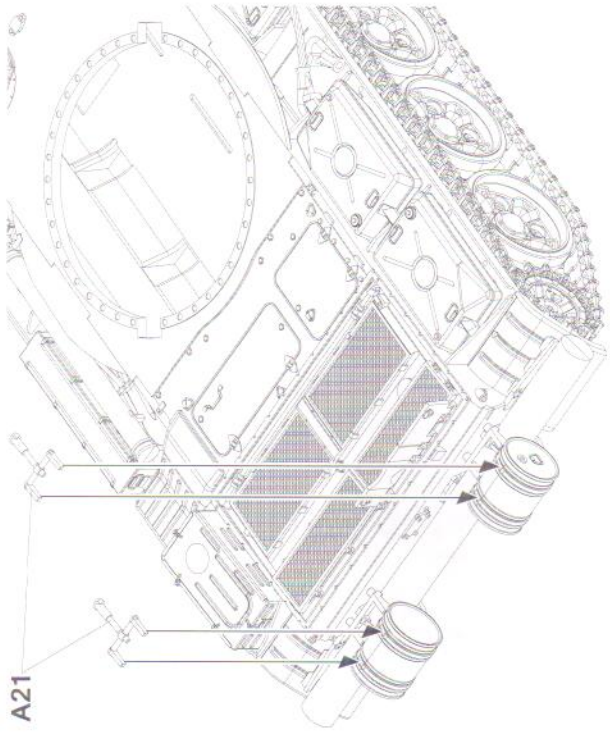

A21

13

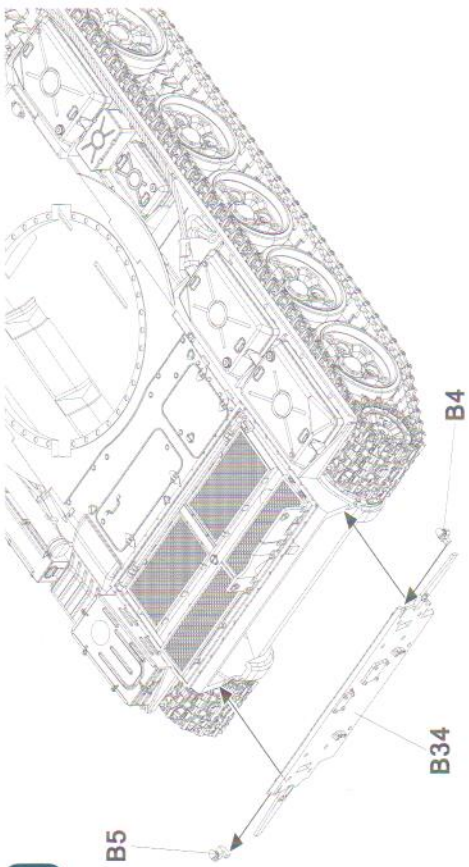

B5

B34

B4

12

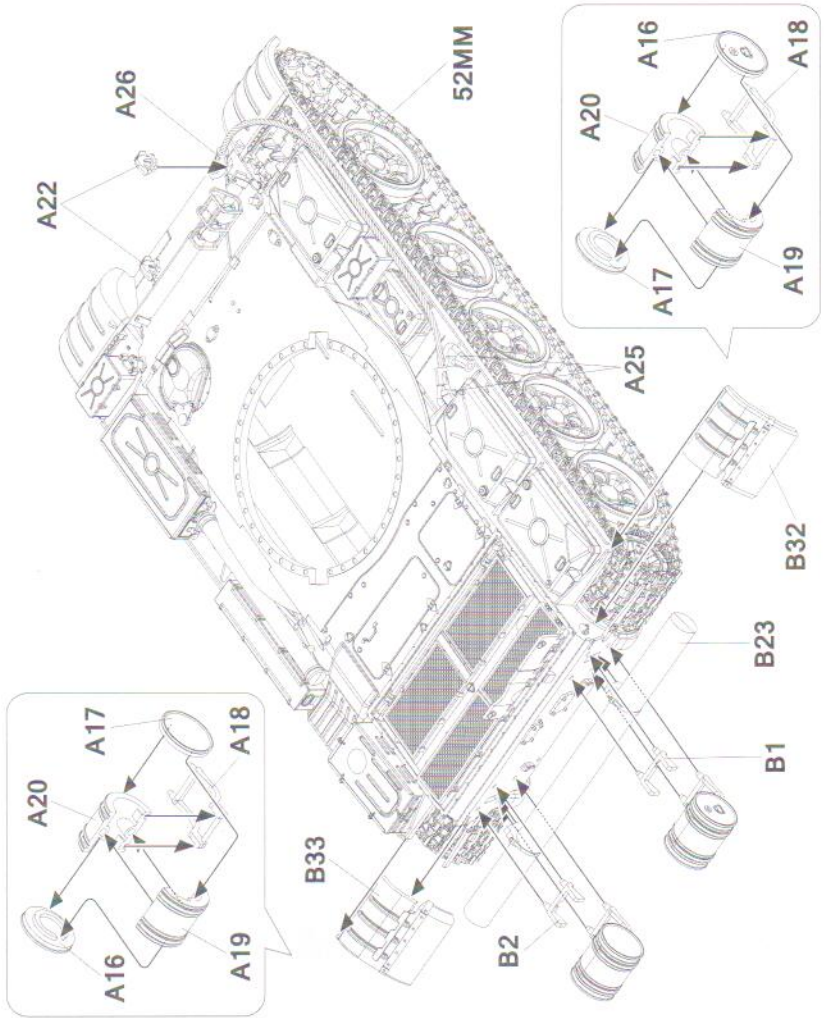

A22

A26

52MM

A20

A16

A17

A18

A19

A25

B32

B23

B1

B2

B33

A20

A16

A17

A18

A19

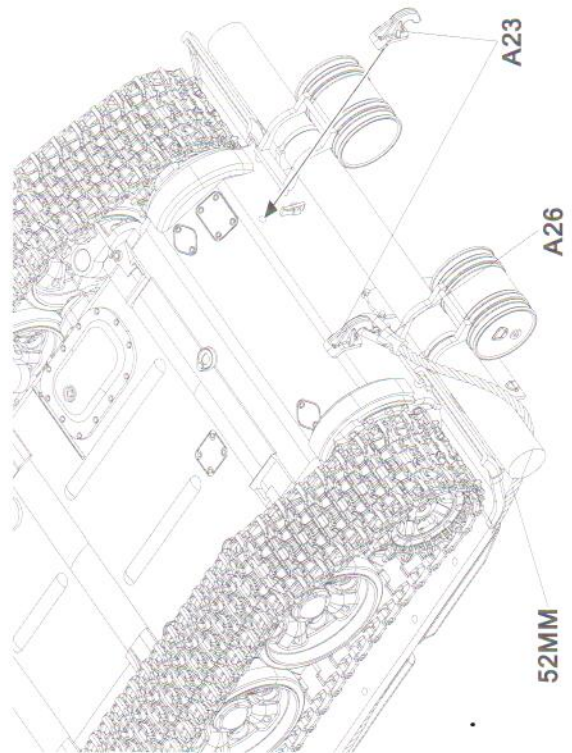

A23

A26

52MM

14



15

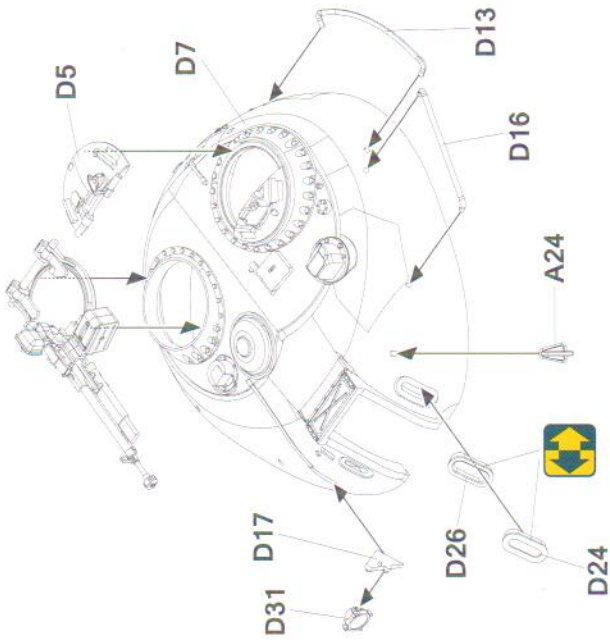
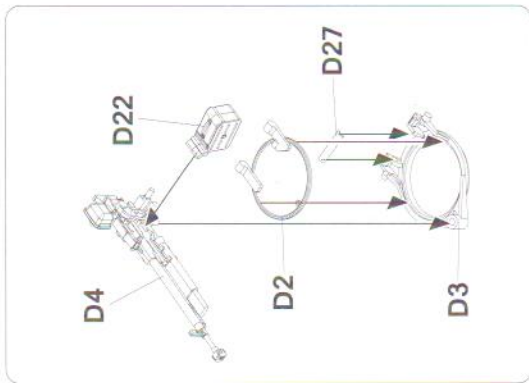

16

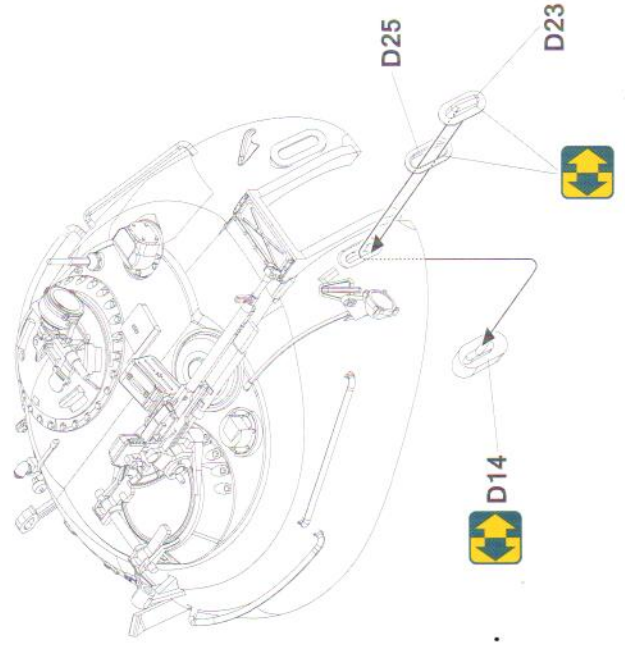
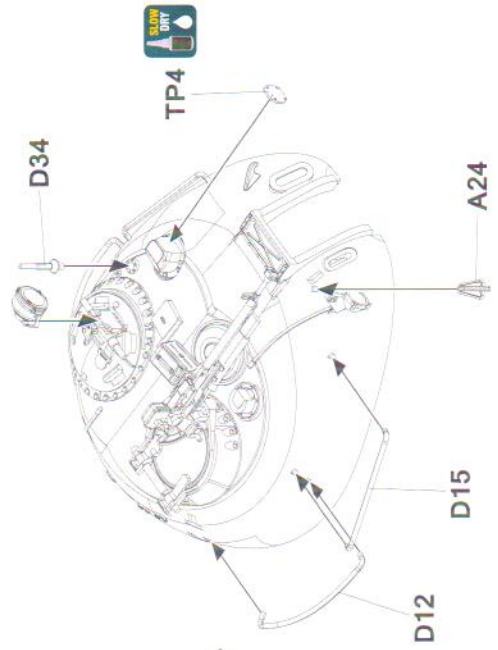
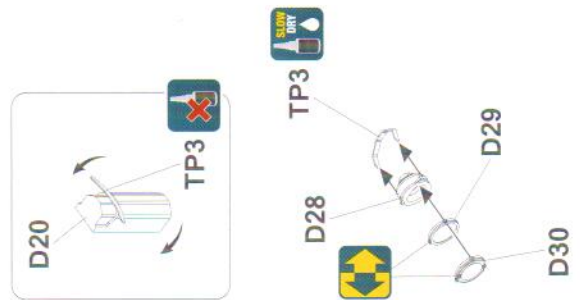
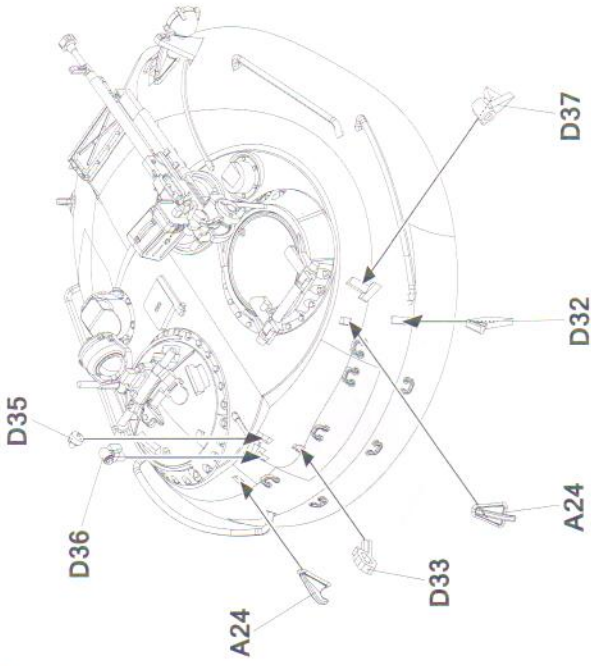



17

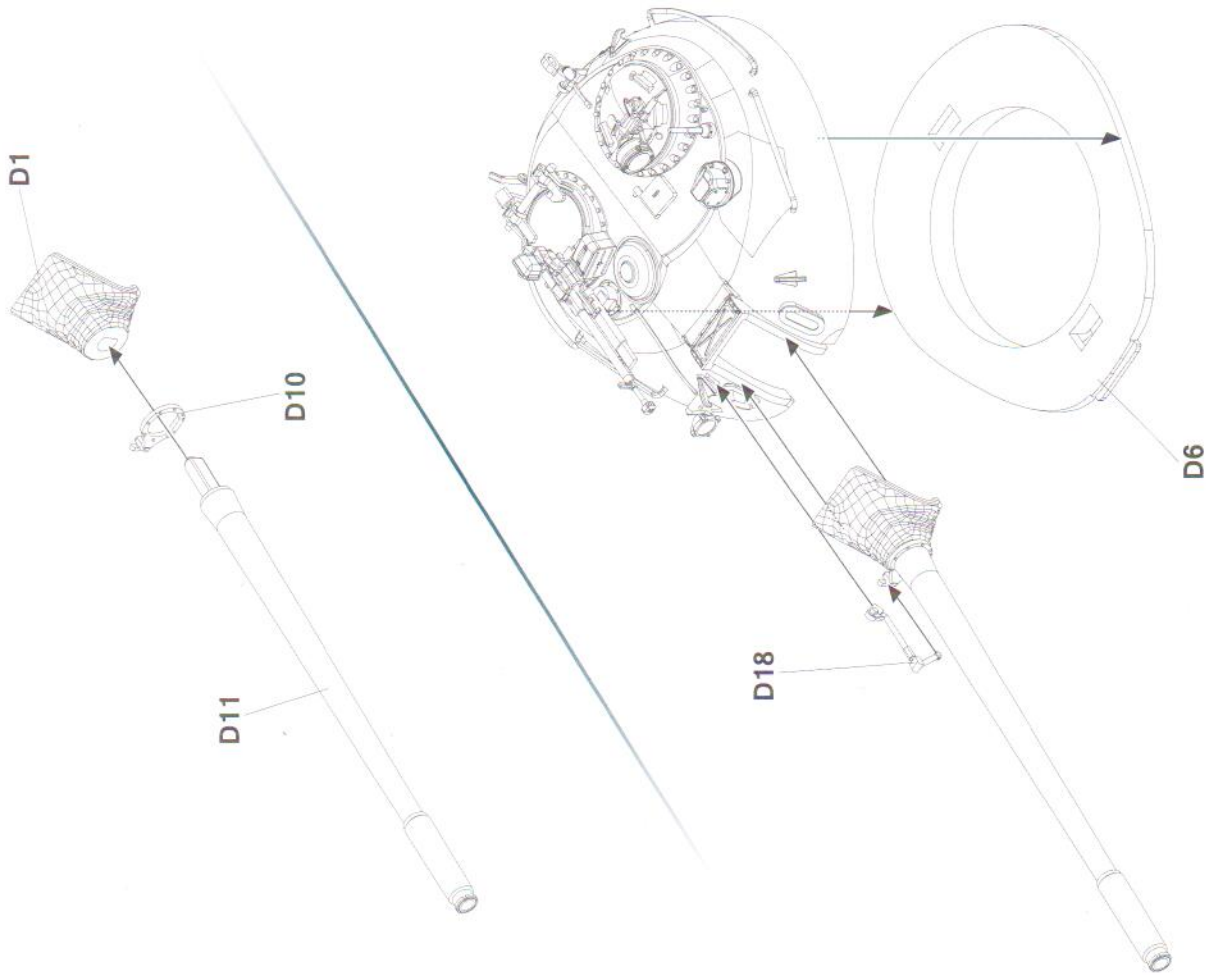

18

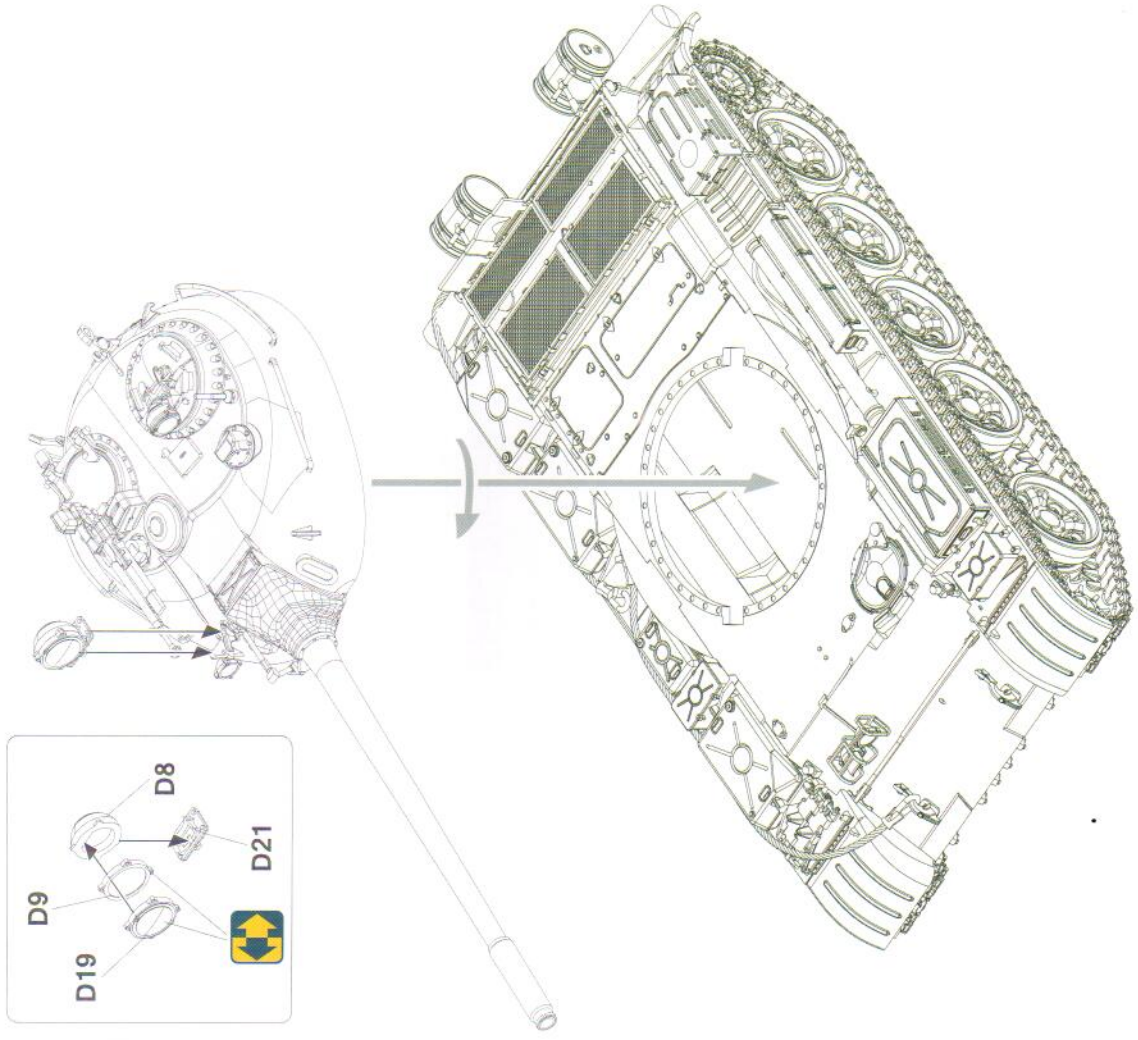



## PAINTING TIPS

- Always apply a layer of primer using a color similar to the camouflage that you are going to apply to your model. A gray primer is suitable for any camouflage. We recommend using acrylic One-Shot Primer from AMMO by Mig Jimenez.
- Apply the base coat of the main color of the camouflage. Dilute paint for correct flow through the airbrush. Typically, dilute paint to the consistency of skim milk, although exact measurements depend on your airbrush, the air pressure used, and the type of application.
- Apply the paint in thin layers, allowing each to dry for a few seconds to avoid flooding the surface. Apply several layers until the color covers properly. Let the paint dry thoroughly before continuing.
- Apply the remaining camouflage colors using the same instructions. To mask individual areas, we recommend Camouflage Masking Putty A.MIG-8012. To mask periscopes, windows, and other small details we recommend Liquid Mask Maskol A.MIG-2032.



## WEATHERING RECOMMENDATIONS

- Apply chips with the color Chipping A.MIG-0044 on edges and other areas exposed to scratches and wear.
- Apply fading effects, highlights, and shadows using Oilbrusher colors. For highlights and fading effects, use a tone lighter than the color of the camouflage. For shadows use a darker shade.
- Apply a wash on the panel lines and around the raised features to highlight all details and imitate the dirt embedded in the recesses. For the best effects, use the color accurately recommended in the color profile guide.
- Apply a filter to integrate the different colors of the camouflage, create tonal variation, and to alter a camouflage color. Always use the color recommended in the color profile guide for best results.
- Apply draining and streaking to recreate the effects left by dirt and rust on the vertical and horizontal areas of the vehicle. For the best effects, use the color accurately recommended in the color profile guide.
- Apply dusting effects with pigments to represent the dust and dirt accumulated on the horizontal zones and recesses of the vehicle. Always use the color recommended in the color profile guide for best results.
- Add mud effects and splashes to the undercarriage, tracks, and the lower areas of the vehicle. You will find the correct colors and textures accurately listed in the color profile guide.
- Include authentic fresh oil spills or spilled fuel by using the special products Fresh Engine Oil A.MIG-1408 and Fuel Stains A.MIG-1409.
- Always add polished metal effects on the tracks, machine guns, and other metal components by gently rubbing Polished Metal pigment A.MIG-3021 with a brush or other suitable tool.

## HOW TO PLACE DECALS



Remove each individual decal from the backing paper with the aid of scissors or a tipped cutting tool.



Immerse the decal in water for 15 to 20 seconds. Slide the decal from the backing paper and position the decal using a brush.



Carefully align the decal to its final position with the tip of a toothpick. If the decal is resistant to repositioning, moisten the area with water.



Press gently with a cloth or absorbent paper to dry excess water and remove any air bubbles that can appear under the decal. Once placed do not disturb the positioning and allow the decal to dry completely.



For the best results, apply Aqua Gloss Clear A.MIG-8212 before and after the process of placing the decals to improve adaptation to the surface and facilitate the following steps.

We recommend the combined use of the Ultra Decal Set A.MIG-2029 and Ultra Decal Fix A.MIG-2030 products for perfect adhesion and surface conformity of your decals.





# T-54B



A.MIG-8502

### Painting and Marking Guide

- A.MIG-033 Rubber & Tires
- A.MIG-034 Rust Tracks
- A.MIG-036 Old Wood
- A.MIG-046 Matt Black
- A.MIG-917 Light Green
- A.MIG-083 Zashchimiyy Zeleno

Vietnam Army 80's

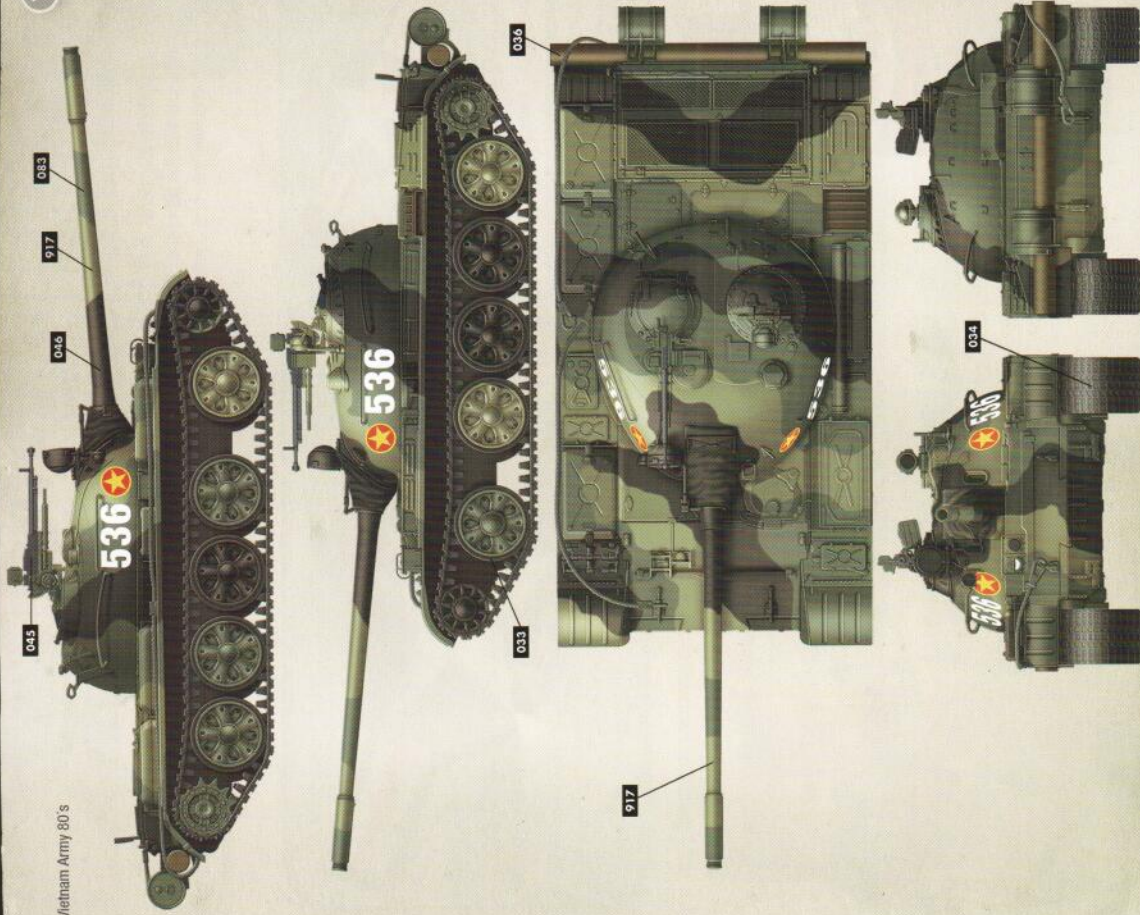

1



# T-54B



A.MIG-8502

### Painting and Marking Guide

- A.MIG-033 Rubber & Tires
- A.MIG-034 Rust Tracks
- A.MIG-036 Old Wood
- Zashchimiyy Zeleno
- A.MIG-083

Vietnam War, NVA Saigon, April 1975

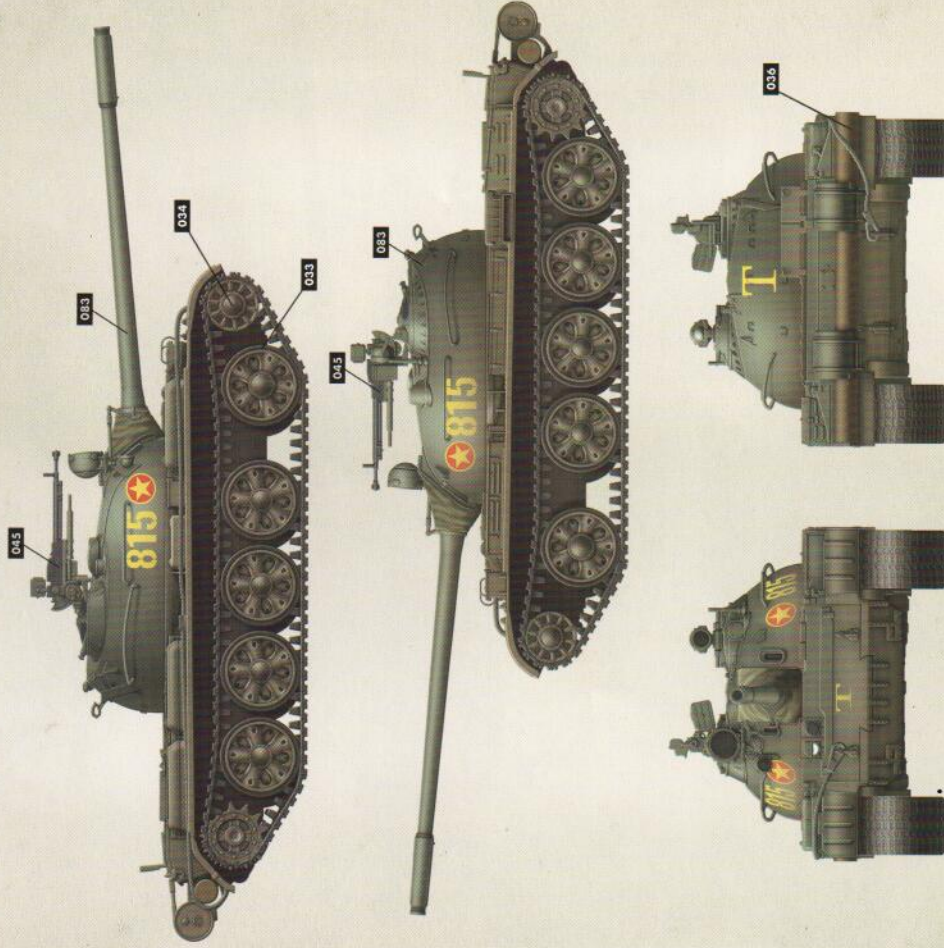

2





# T-54 B



A. MIG-8502

### Painting and Marking Guide

A. MIG 033 Rubber & Tires

A. MIG 034 Rust Tracks

A. MIG 036 Old Wood

A. MIG 045 Gun Metal

A. MIG-083 Zashchitny Zeleno

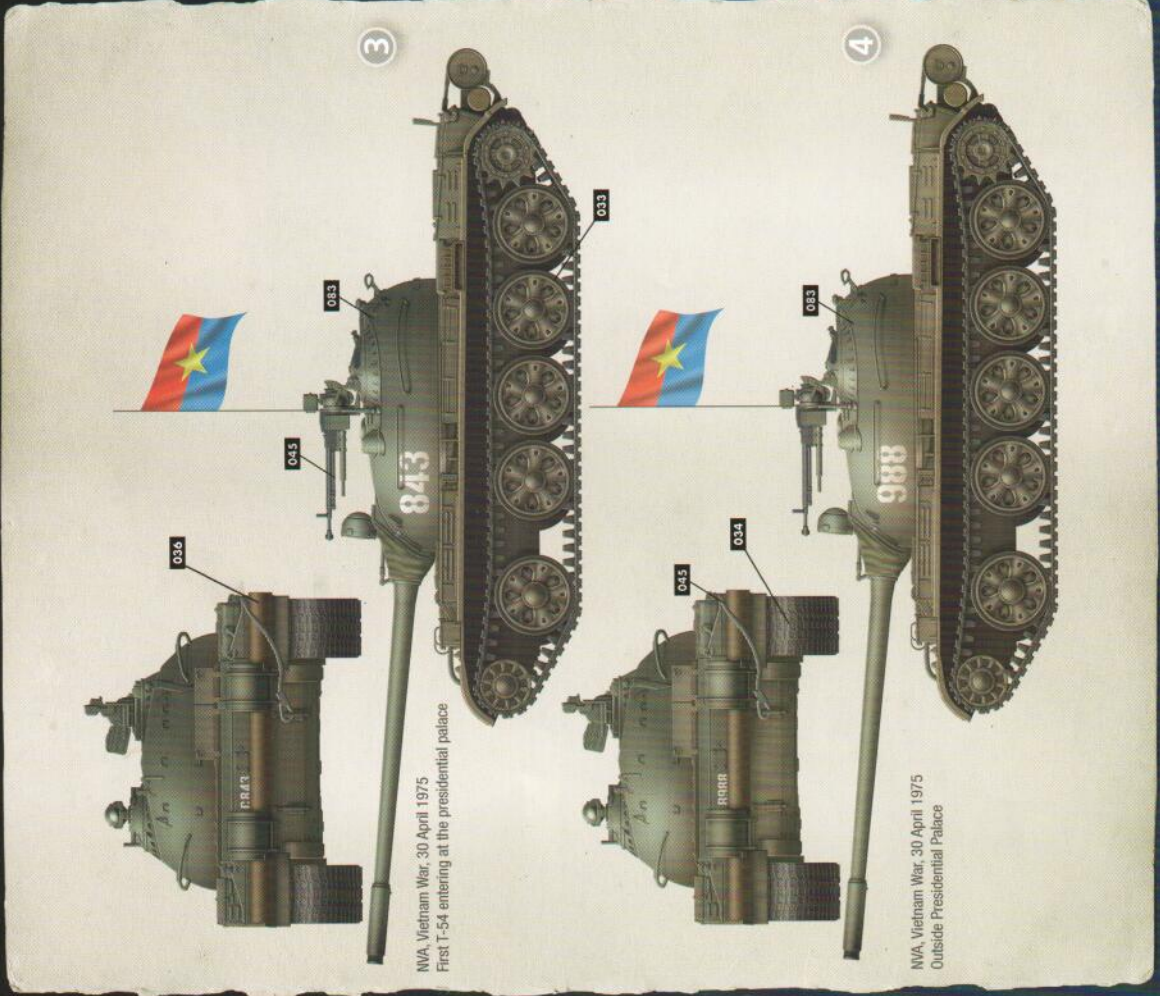

# T-54 B



A. MIG-8502

### Painting and Marking Guide

A. MIG 033 Rubber & Tires

A. MIG 034 Rust Tracks

A. MIG 036 Old Wood

A. MIG 045 Gun Metal

A. MIG 029 New Iraqi Army Sand

A. MIG-083 Zashchitny Zeleno

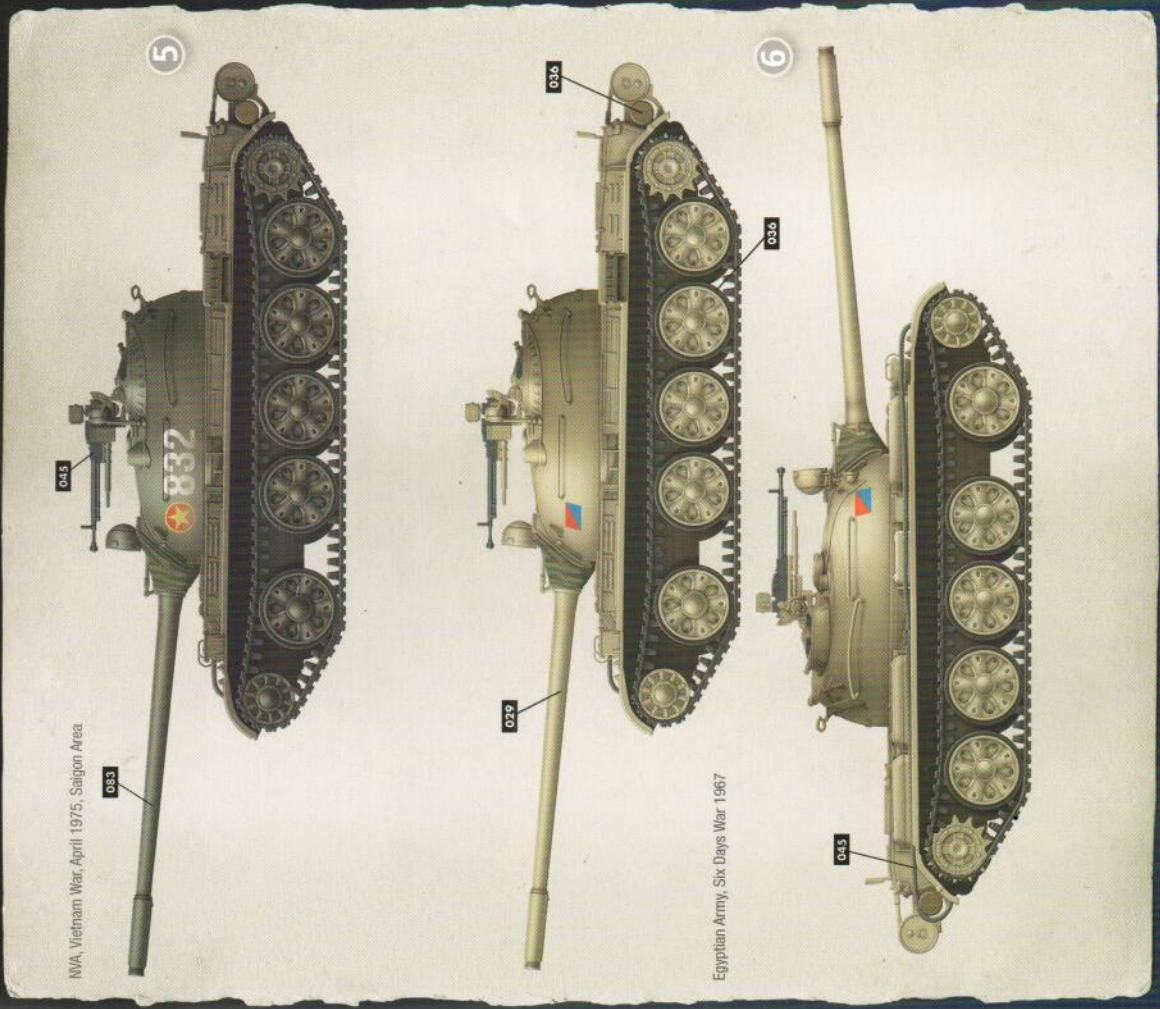



# T-54B



A.MIG-8502

## Painting and Marking Guide

- A.MIG 033 Rubber & Tires
- A.MIG 034 Rust Tracks
- A.MIG 036 Old Wood
- A.MIG 045 Gun Metal
- A.MIG 931 Russian Dark base
- A.MIG 930 Sand Yellow
- A.MIG 913 Red Brown Base

Syrian Army Yom Kippur War 1973

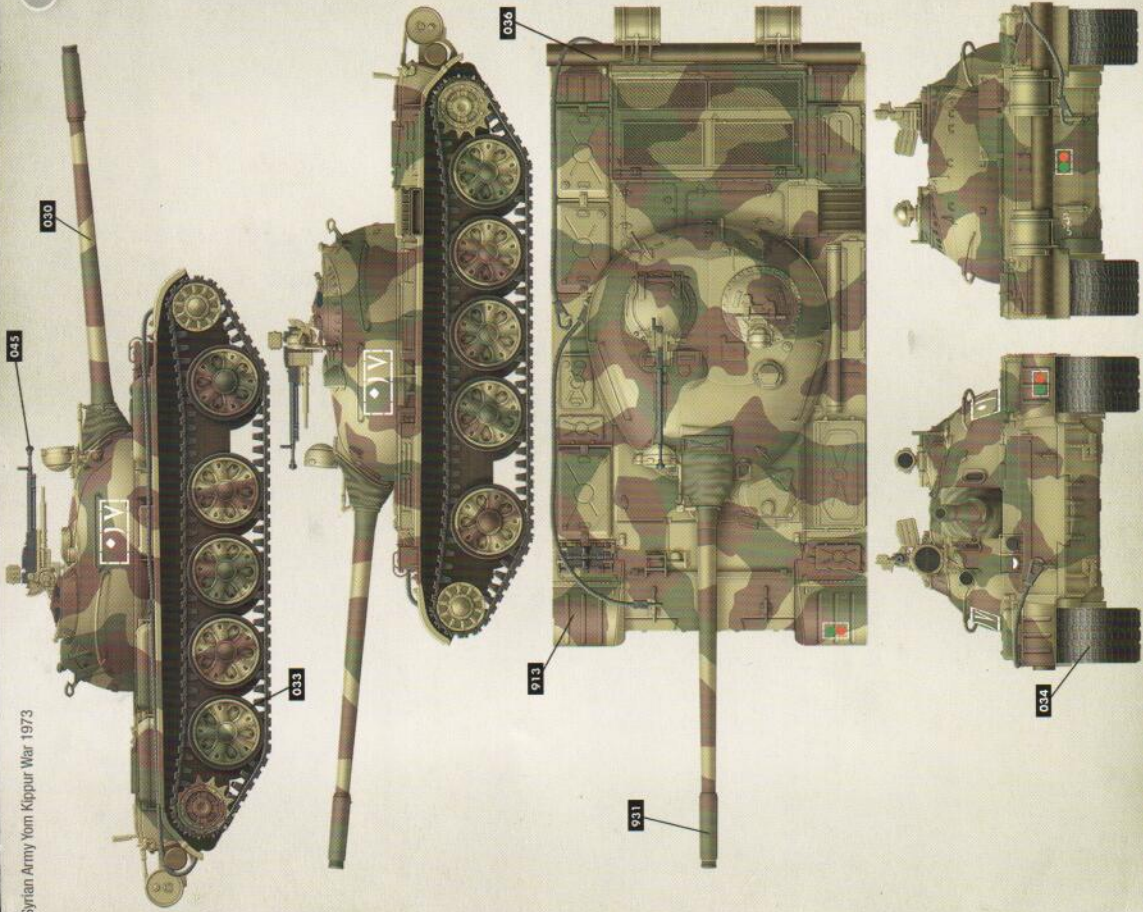

7

# T-54B



A.MIG-8502

## Painting and Marking Guide

- A.MIG 033 Rubber & Tires
- A.MIG 034 Rust Tracks
- A.MIG 036 Old Wood
- A.MIG 045 Gun Metal
- A.MIG 915 Dark Green
- A.MIG 029 New Iraqi Army Sand
- A.MIG 914 Red Brown light

Yom Kippur War October 1973, Suez Canal, Sinai Side

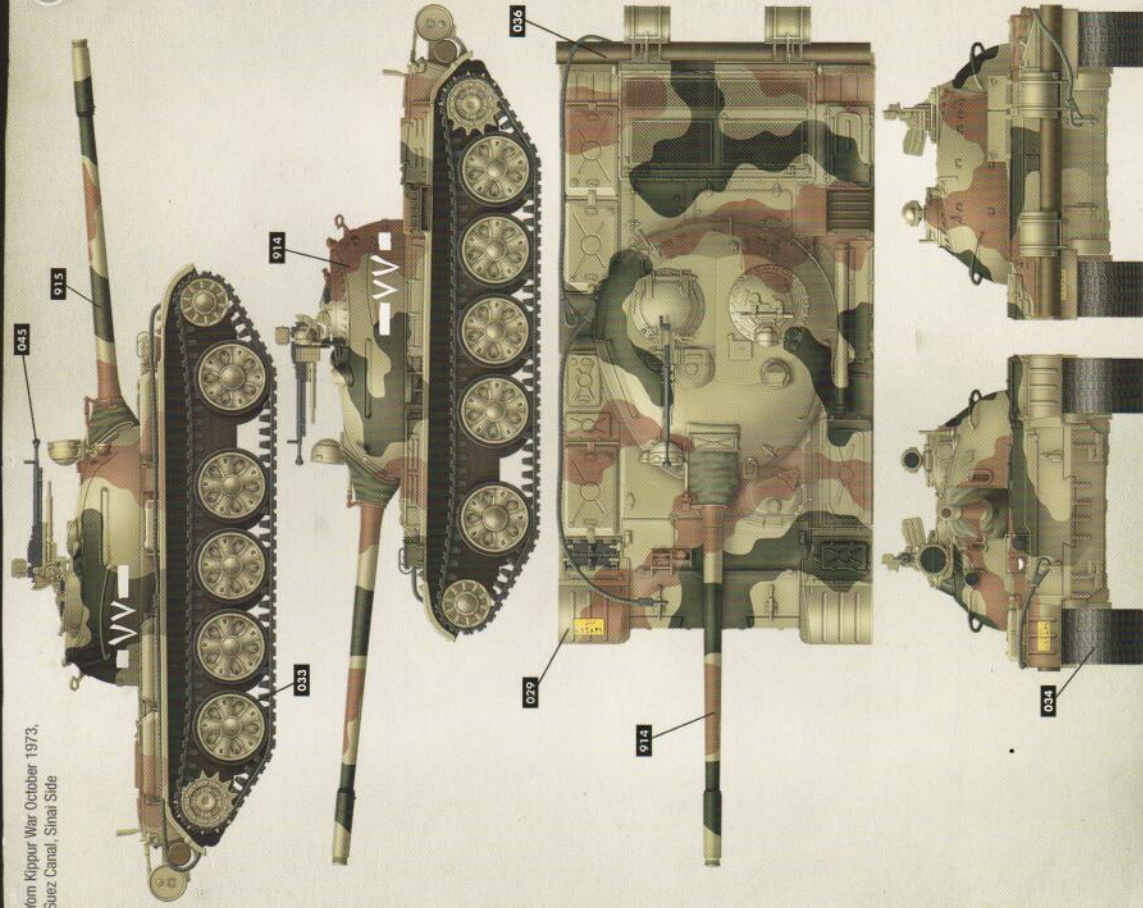

8



# T-54B



A.MIG-8502

## Painting and Marking Guide

- A.MIG 033 Rubber & Tires
- A.MIG 034 Rust Tracks
- A.MIG 036 Old Wood
- A.MIG 045 Gun Metal
- A.MIG 045 Old Rust
- A.MIG 067 Light Sand Grey
- A.MIG 083 Zaphchimy Zeleno
- A.MIG 935 Russian Shine

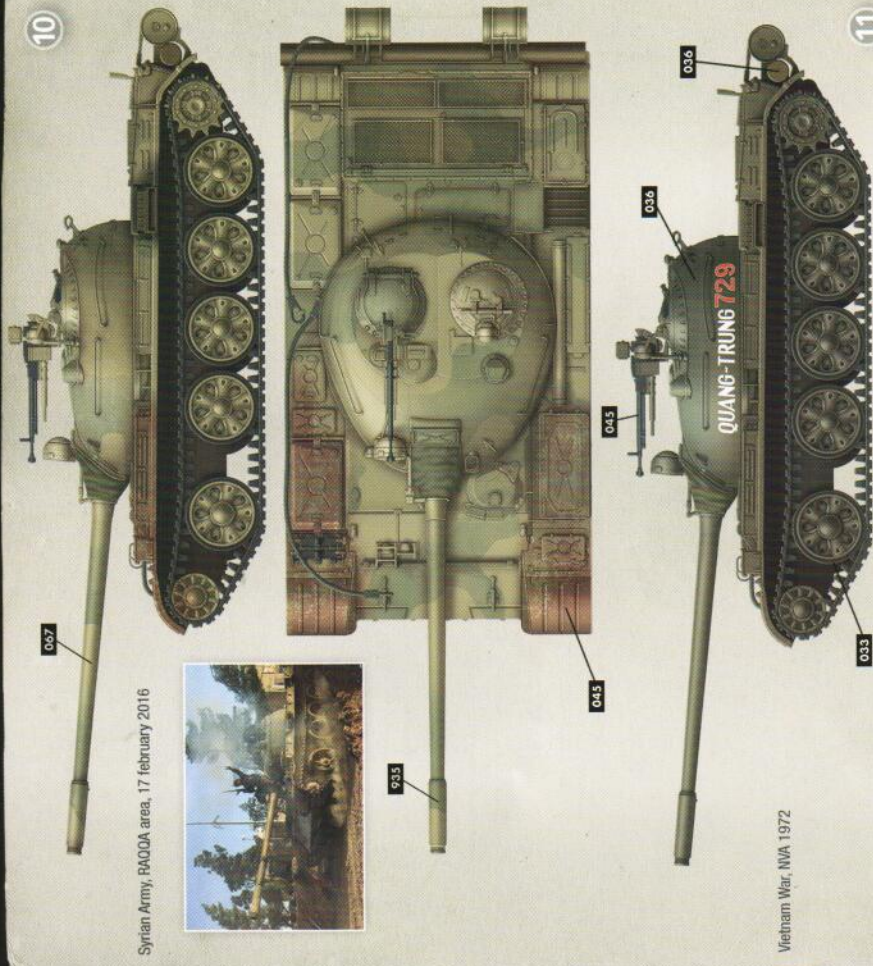

Syrian Army, RAQQA area, 17 february 2016

Vietnam War, NVA 1972

11



# T-54B



A.MIG-8502

## Painting and Marking Guide

- A.MIG 033 Rubber & Tires
- A.MIG 034 Rust Tracks
- A.MIG 036 Old Wood
- A.MIG 045 Gun Metal
- A.MIG 933 Russian Light Base
- A.MIG 935 New Iraqi Army Sand
- A.MIG 914 Red Brown Light

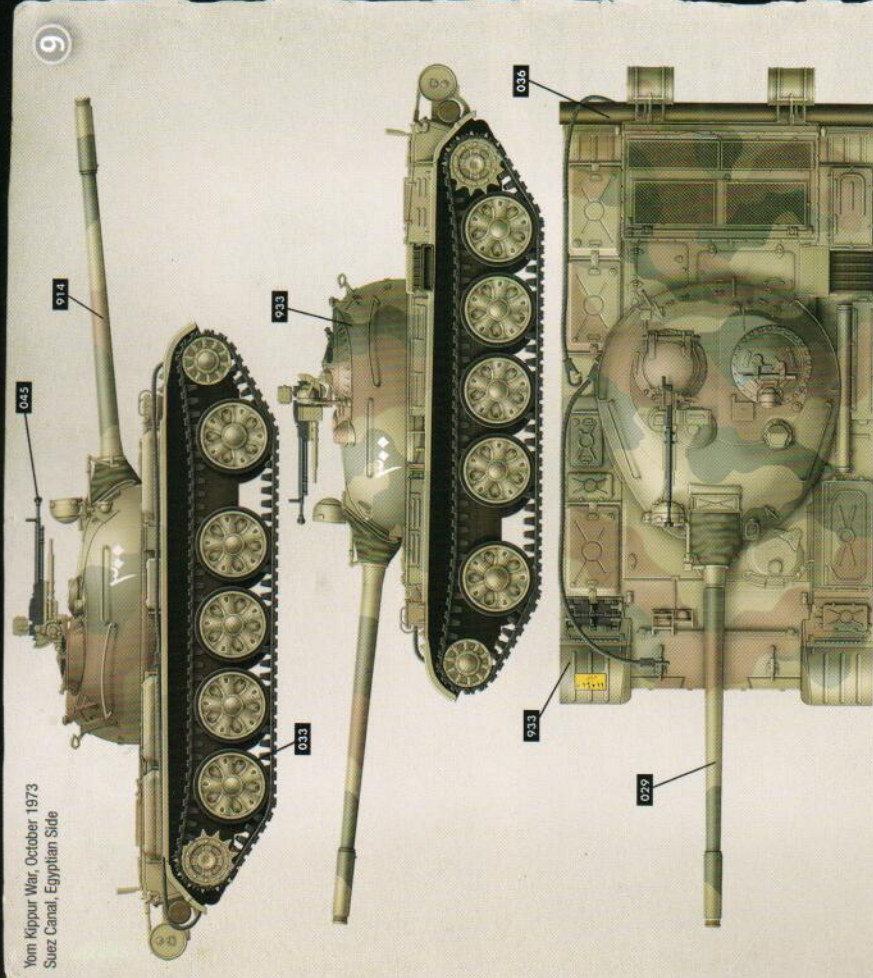

Yom Kippur War, October 1973  
Suez Canal, Egyptian Side

9

