

# KC-135A STRATOTANKER

STOCK No. 8848

Form No. 099 - 8848

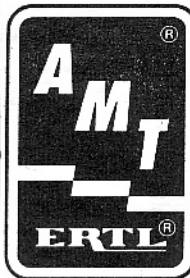

The ERTL Co. would like to express our gratitude to the following individuals for their assistance in the development of this model kit; Alan Griffith, Major Bill Strandberg ( U S A F ), Tom Bly, Jennings Heilig and Al Lloyd.



The KC-135 can trace its heritage back to the first successful attempt at air-to-air refueling, when two DH-4 biplanes transferred fuel from one to the other. This was done the old fashioned way, one pilot dangling a hose out so the other plane could catch it and fill the tanks.

In the early fifties, Boeing aircraft came up with a concept to market a jet transport that could be used by both the military and civilian aviation companies. Further, Boeing felt that it should be a jet powered plane to keep step with future military planes and faster airliners. Their experience with the B-47 gave them good cause to believe this.

Research and development of the new jet transport was included with another Boeing project, the Model 367 series, to hide it from competitor's prying eyes. They even went so far as to show a C-97 fuselage mated to swept wings and tail with double pod jet engines slung under the wings.

The actual design was, of course, an all new aircraft, model number 367-80 (or dash 80 for short). It was longer and more streamlined than its predecessor, the Boeing KC-97G, a piston powered tanker. The wings were swept back at 35 degrees and both the wings and tail had a pronounced dihedral. The first prototype was rolled out at Renton, Washington on 14 May, 1954. It made its first flight on 15 July of the same year. Nicknamed the Dash-80, this first prototype served as the forerunner to both the KC-135 and the civilian version, the well-known Boeing 707.

In August of 1954, the USAF announced it would purchase twenty-nine tanker/transports under the designation of KC-135. In July of 1956, the first production KC-135 rolled out of the Renton plant. It was over 8 feet longer and 12 inches

bigger in diameter than the dash-80, but was similar in appearance of course. This first KC-135 Stratotanker, the City of Renton, is remarkably still in service, retrofitted to the EC-135K configuration.

The KC-135 began operational service on 30 April, 1957. It has a crew of four, pilot, copilot, navigator and boom operator, known as the "boomer". The boomer also serves as the loadmaster when the plane is loaded with fuel. The flying boom refueling system is what the KC-135 is all about. The refueling system is controlled and operated from a pod located under the aft end of the fuselage. Access to the pod is through a door in the floor of the cabin which stretches the full length of the fuselage. The boomer lies on his stomach on a padded pallet in the pod, looking down through an observation window facing the rear of the plane. He operates the flying boom with a pair of control handles, moving the ruddervators which "fly" the boom down to a thirsty plane flying in formation. The boom is housed against the bottom of the fuselage when not in use. The KC-135 has two fuel tanks in each wing (plus a reserve), another tank is in the wing center section. In the fuselage there are nine fuel cells under the cabin deck and a large tank is located in the rear of the fuselage as well. The wing tanks are for the KC-135 itself, while the fuselage tanks are for refueling other aircraft.

KC-135 is still very much in active service and will probably continue well into the next century, not a bad life span for a plane that was originated in the middle of the twentieth century. Enjoy your model of this remarkable flying fuel station, the KC-135 Stratotanker.

# IMPORTANT

Before you begin to assemble your model kit, study the instructions carefully. This will help you to familiarize yourself with the part locations as you proceed. Prior to cementing parts together, be sure to "TEST FIT" them in order to assure proper alignment and also to check for excess "FLASH" that may occur along parting lines. Use a sharp hobby knife or file to remove flash if necessary.

If you wish to paint your model, various sub-assemblies and components should be painted before any parts are attached. During assembly, you may note that the recommended color is stated after the part name.

This model kit is molded from the finest high-impact styrene plastic. Use only paints and cements which are specifically formulated for styrene. Read all labels and warnings carefully.

Because the cement will only adhere to bare plastic, it is necessary to remove any paint or "plating" from the area to which the cement is to be applied.

## BUILDING TIPS FOR THE ADVANCED MODELER

For the best possible finish, your kit should be painted, even if molded in color. Paint should be applied evenly, in several thin coats rather than one heavy coat. The first coat should not completely cover the surface. Each layer should be allowed to thoroughly dry before the next is applied. Also, each coat should be "wet sanded", except for the final coat, using No.1200 wet or dry sandpaper which is slightly damp. Be careful not to remove any detail while sanding.

It is important to keep your hands clean when working with your model and wash parts thoroughly before painting to remove any mold release agent that may have been used during manufacture, body oil from your hands, sanding residue, and dust, which is naturally attracted to plastic by static electricity. Use a mild solution of dishwashing detergent and water. A tack rag should be used to dry the parts, DO NOT use paper towels or tissues, since they will leave lint on the part.

Parting lines and glue joints should be sanded or filed prior to painting and cementing. Because paint has a tendency to draw away from sharp edges, they should be lightly filed. Use filler putty designed for plastic to fill small gaps that may occur between parts and to blend contours. This should be done only after the first, or "primer," coat of paint is applied.

When painting a two-tone body, the lightest color should be painted first. Use frosted, or "magic," tape to mask off the area you do not want painted. After the second color is dry to the touch, the tape can be removed. Use a very fine brush to touch up edges if necessary. If decals are to be added, do so before adding any gloss coat. A gloss coat will help even out the edges between the two colors as well as set the decals.

## RECOMMENDED TOOLS

### HOBBY KNIFE

Use a sharp hobby knife to remove parts from the trees. The knife may also be used to remove parting lines and flash.

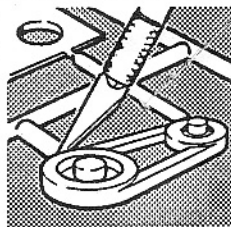

### TWEEZERS

Use tweezers to hold small parts during assembly, painting and when applying cement.

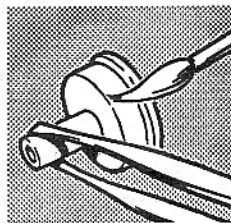

### BRUSH

We recommend the use of liquid polystyrene cement. Apply with a fine brush. Use sparingly or a sloppy job will result.

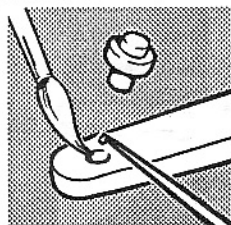

## READ ALL LABELS AND WARNINGS CAREFULLY

We take great pride in providing the finest model kits available, giving strong attention to detail and craftsmanship. Should you have any difficulty with assembly or missing parts, please call the appropriate number listed below between the hours of 8:00 am to 4:30 pm central time, Monday through Friday.

In the U.S.A. call toll free

800 - 553 - 4886

Outside of the United States call

1 - 319 - 875 - 2000

When in the Midwest, please visit the ERTL Company for a tour of the AMT production facilities, 10am & 1pm weekdays. Reservations suggested.

# STEP 1

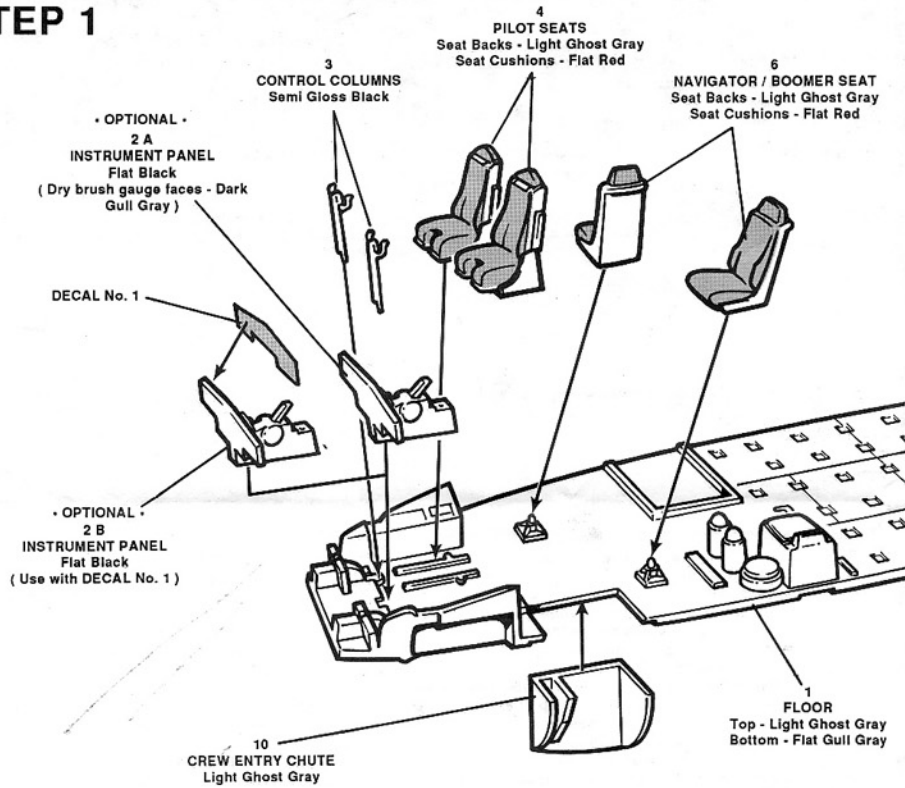

# STEP 2

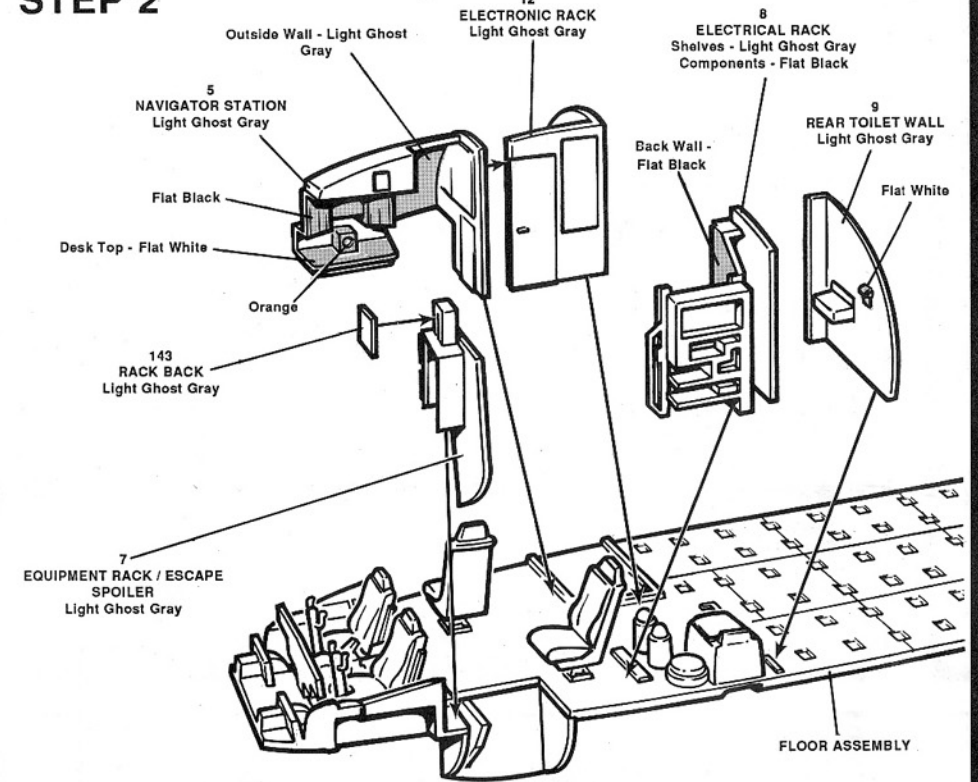

# STEP 3

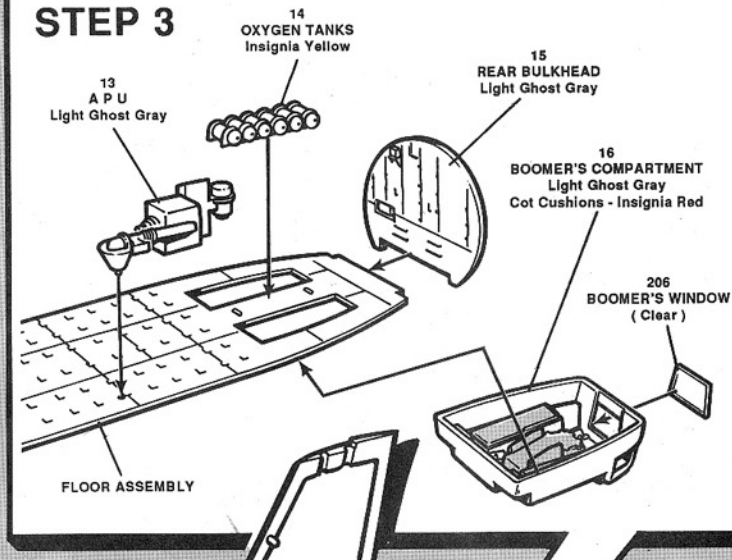

# STEP 4

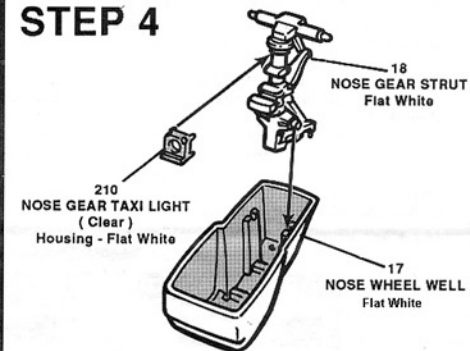

# STEP 5

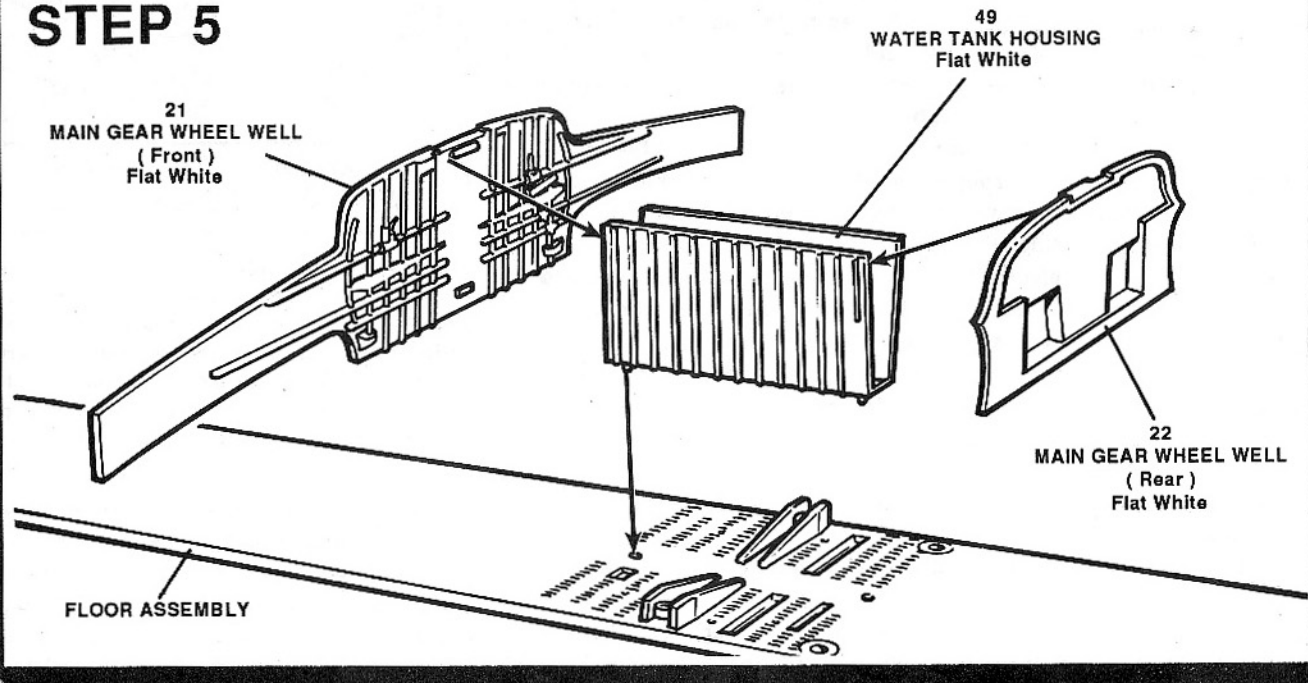

# STEP 6

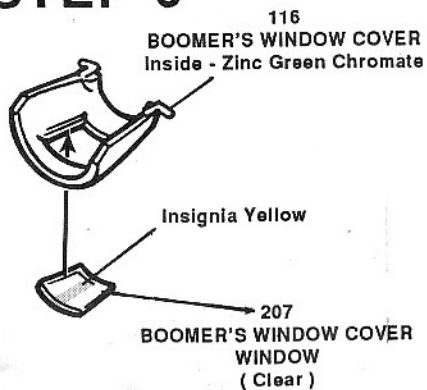

# STEP 7

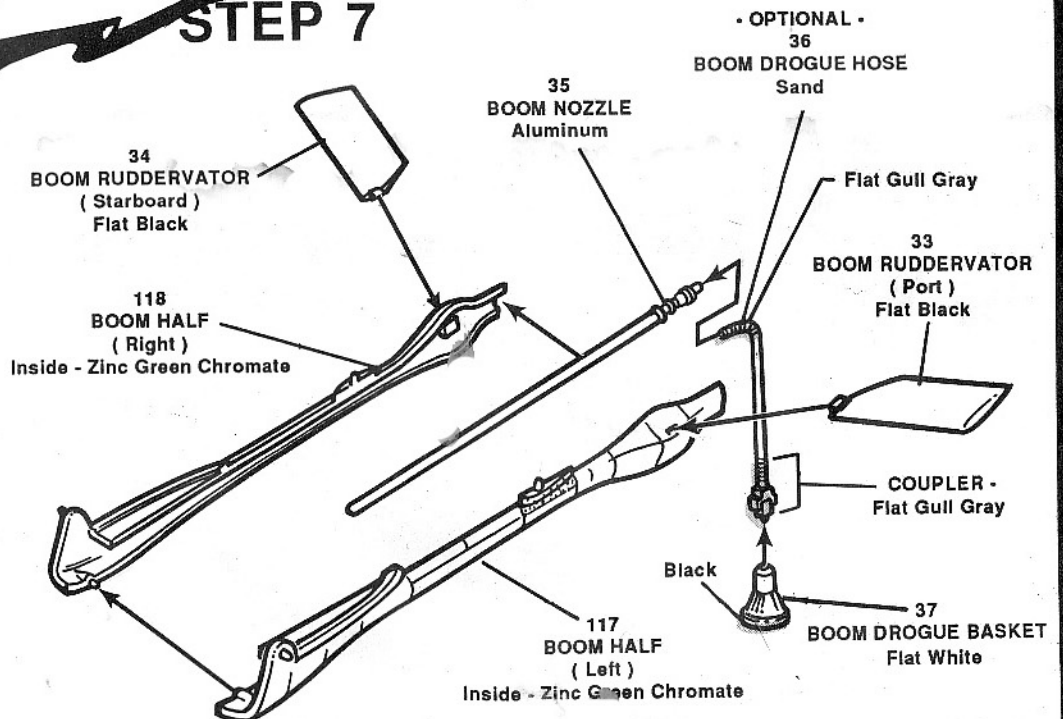

# STEP 1

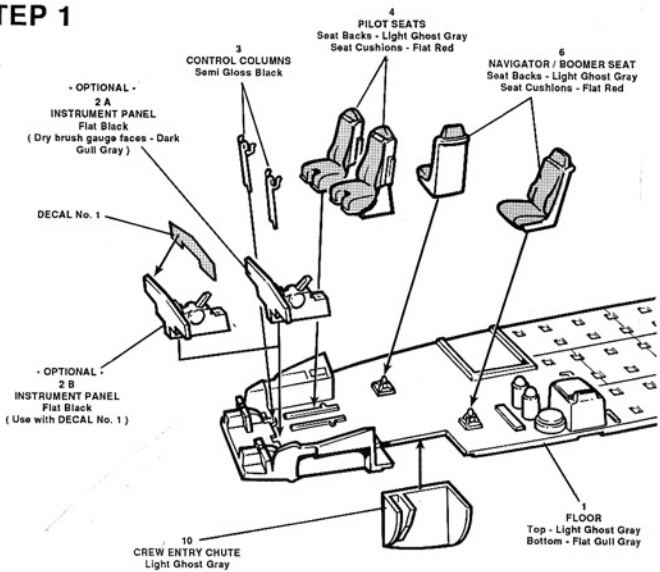

# STEP 2

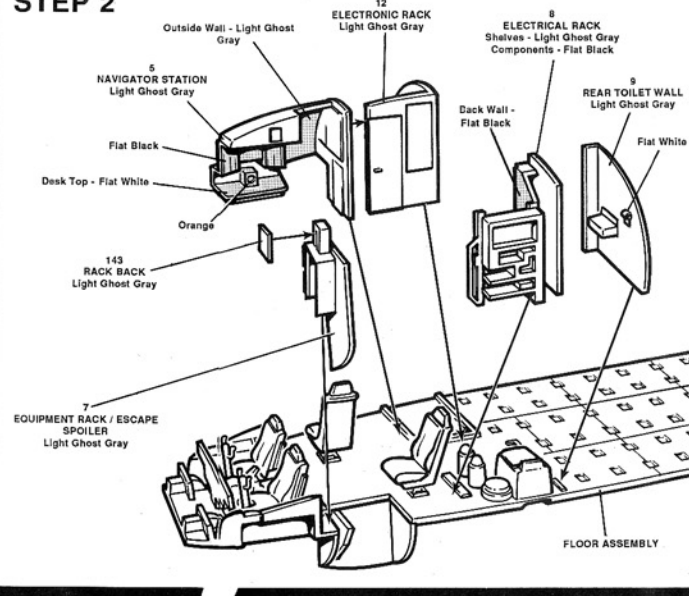

# STEP 3

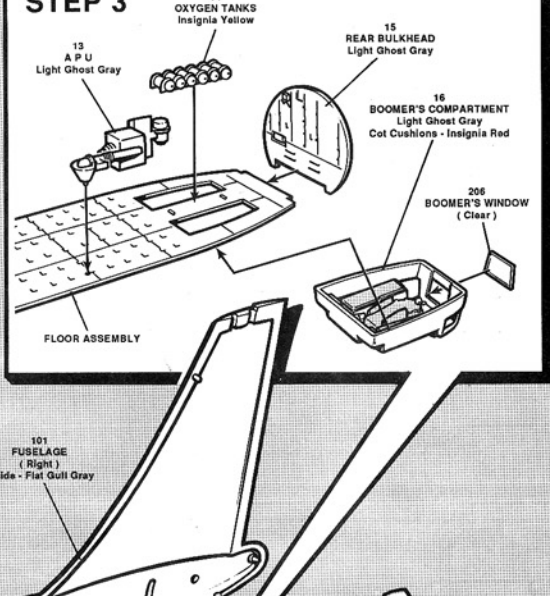

# STEP 4

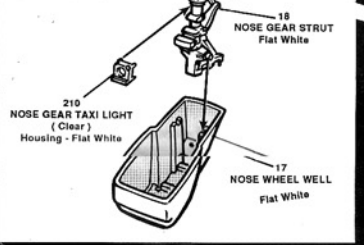

- Flat Gull Gray - FS 36440
- Flat White - FS 37875
- Flat Black - FS 37038
- Light Ghost Gray - FS 36375
- Insignia Red - FS 31136
- Insignia Yellow - FS 35538

## ASSEMBLY SEQUENCE

- FINISH STEPS 1 THROUGH 7.
- IF BUILDING CREW DOOR (#112), CARGO DOOR (#114) OR GEAR WELL DOORS (#S 113, 127, 128, 129 and 130) IN THE CLOSED POSITION, CEMENT THESE PARTS TO THE FUSELAGE NOW (SEE STEPS 11 and 12).
- PAINT THE INSIDE OF THE FUSELAGE Flat Gull Gray.
- IF BUILDING WITH LANDING GEAR IN THE LOWERED POSITION, CEMENT THE ASSEMBLED NOSE GEAR WELL TO THE RIGHT FUSELAGE (#101).
- CEMENT THE ASSEMBLED FLOOR TO THE LEFT FUSELAGE (#100).
- ADD 20 GRAMS OF WEIGHT TO THE INSIDE OF THE NOSE OF THE AIRCRAFT.
- CEMENT BOTH FUSELAGE HALVES TOGETHER TRAPPING THE ASSEMBLED BOOM AND BOOMER'S WINDOW BETWEEN THEM.
- CEMENT THE BOOMER'S HOUSING (115) TO THE ASSEMBLED FUSELAGE.

# STEP 5

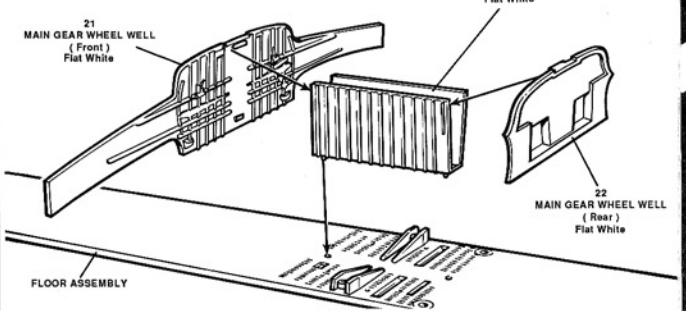

# STEP 6

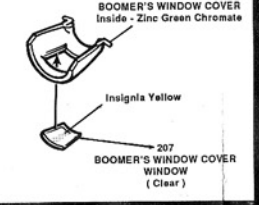

# STEP 7

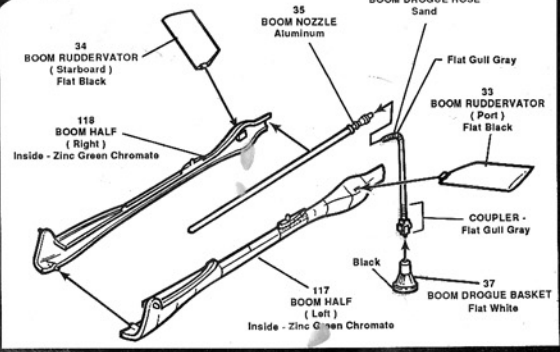

The ERTL COMPANY, Inc.  
Highways 136 & 20  
P. O. Box 500  
Dyersville, Iowa 52040 - 0500  
Printed in the U. S. A.

## STEP 8

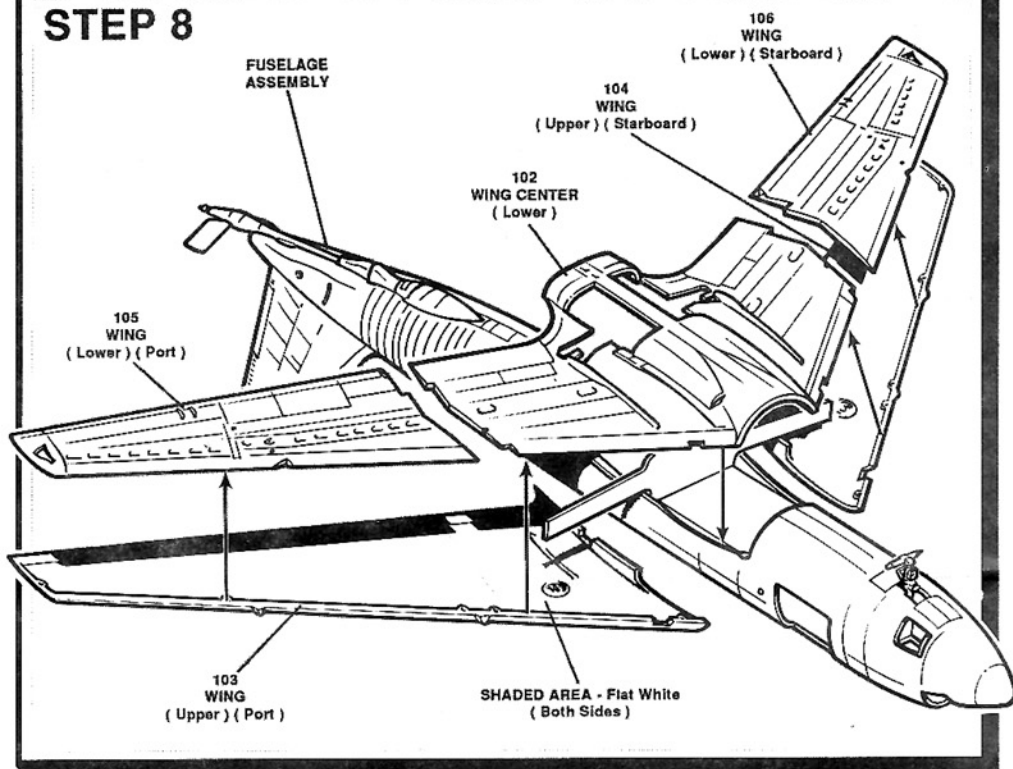

## STEP 9

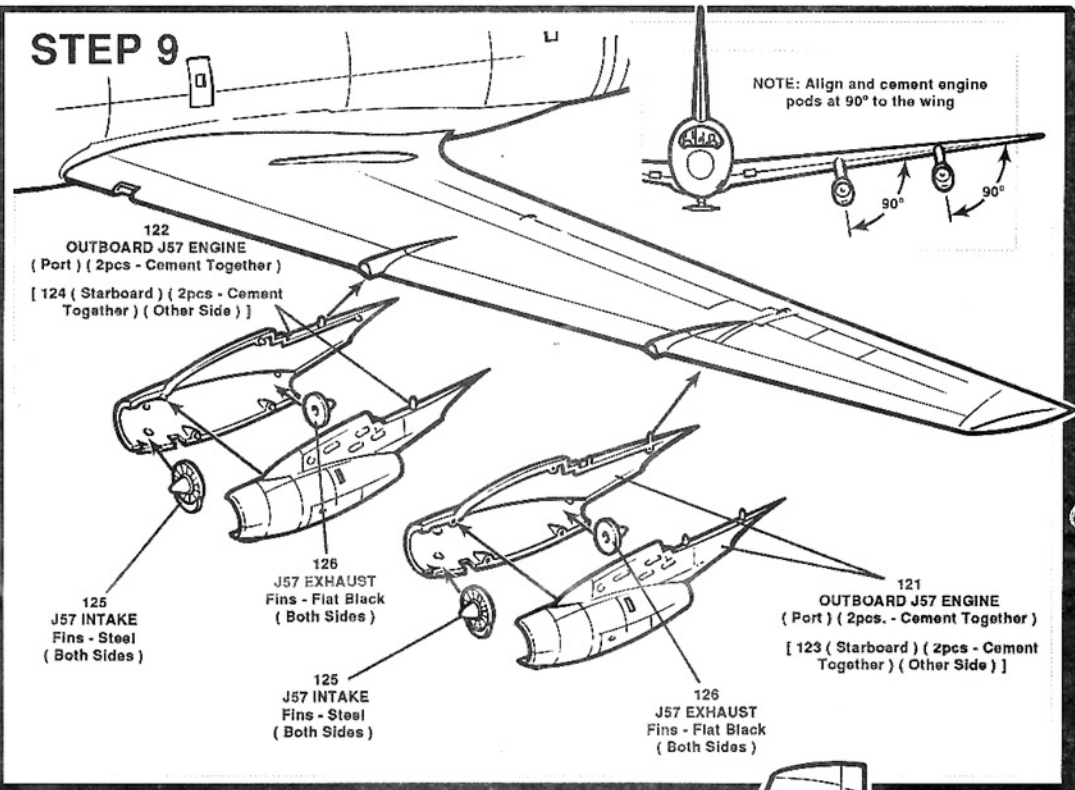

## STEP 10

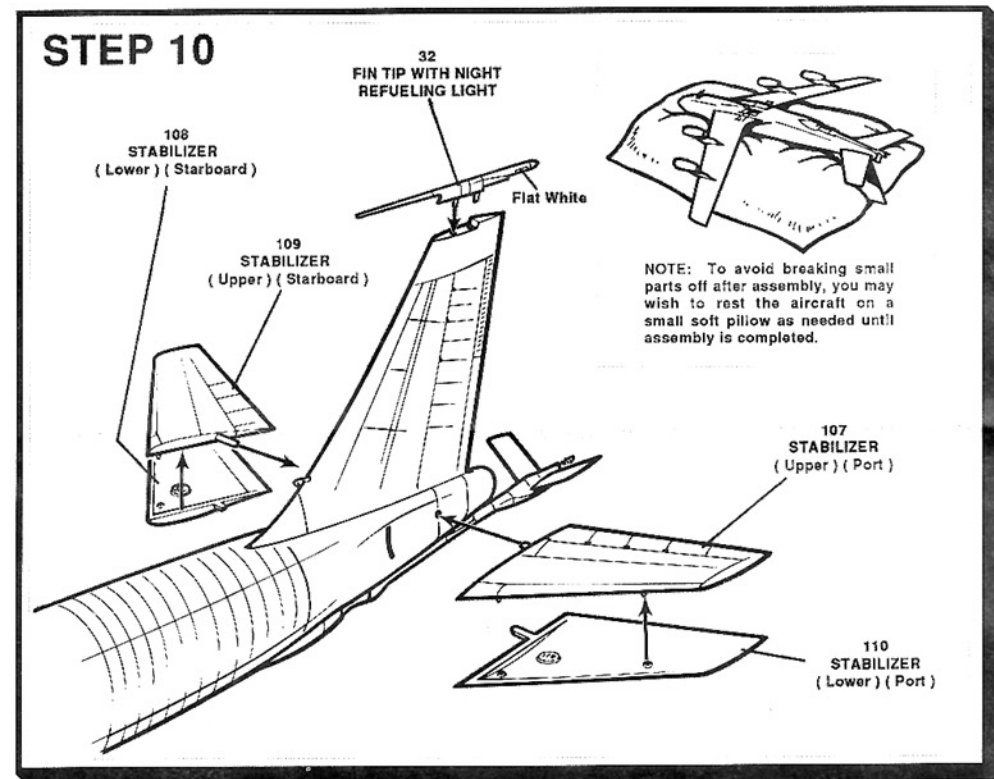

## STEP 11

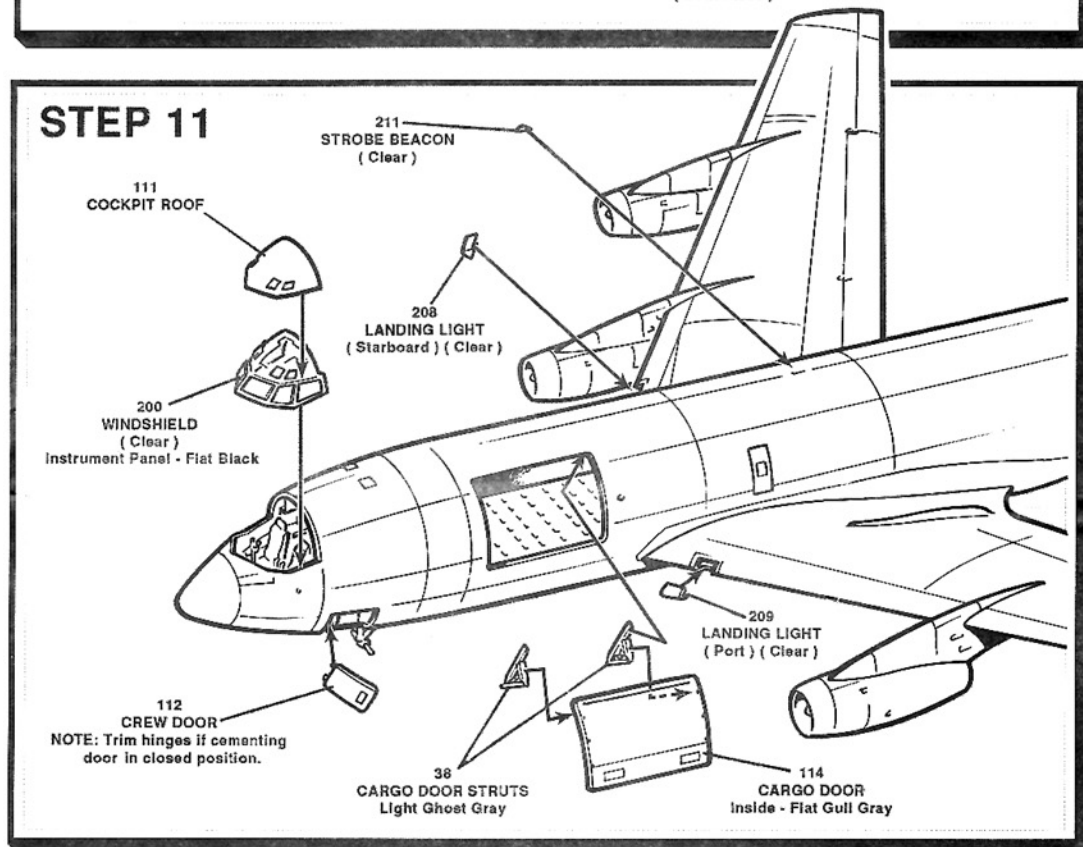

# STEP 12

NOTE: Assemble eight main gear wheels.

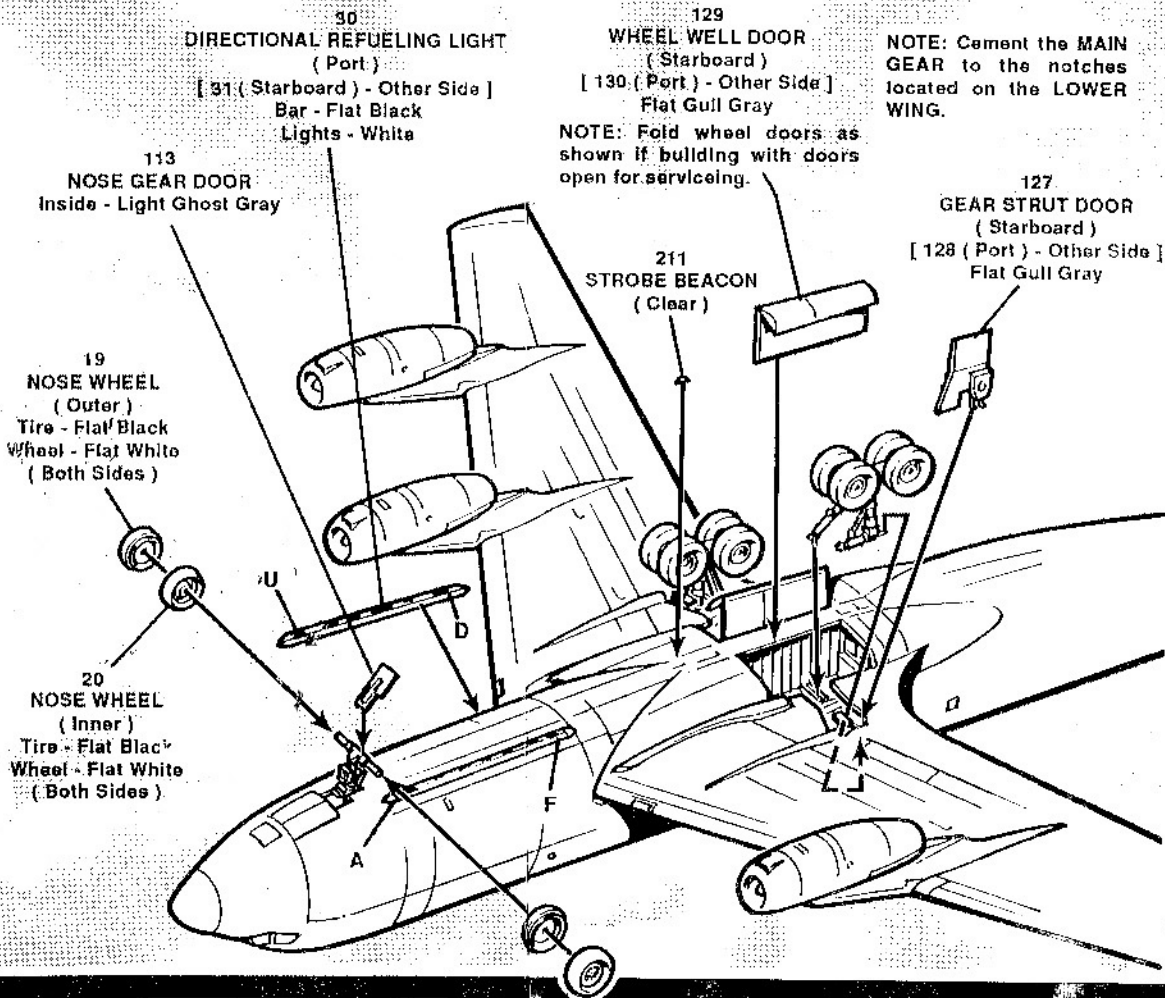
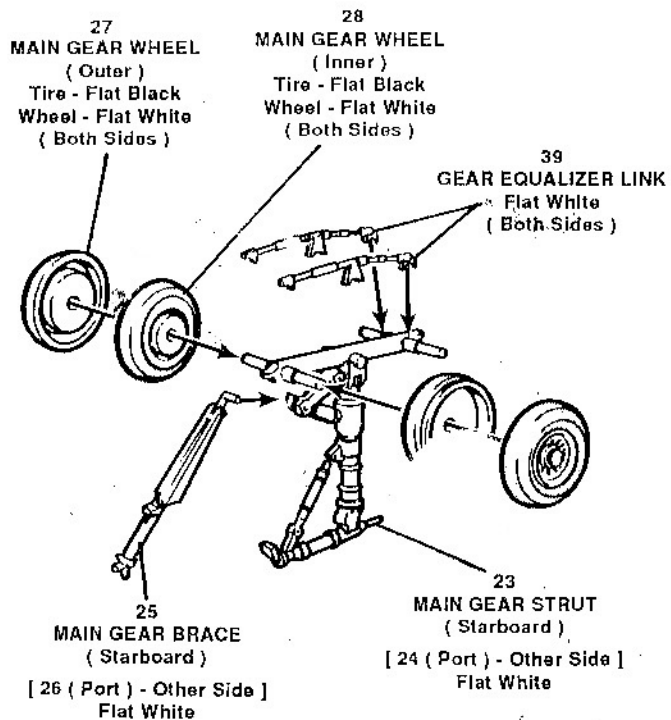

# STEP 13

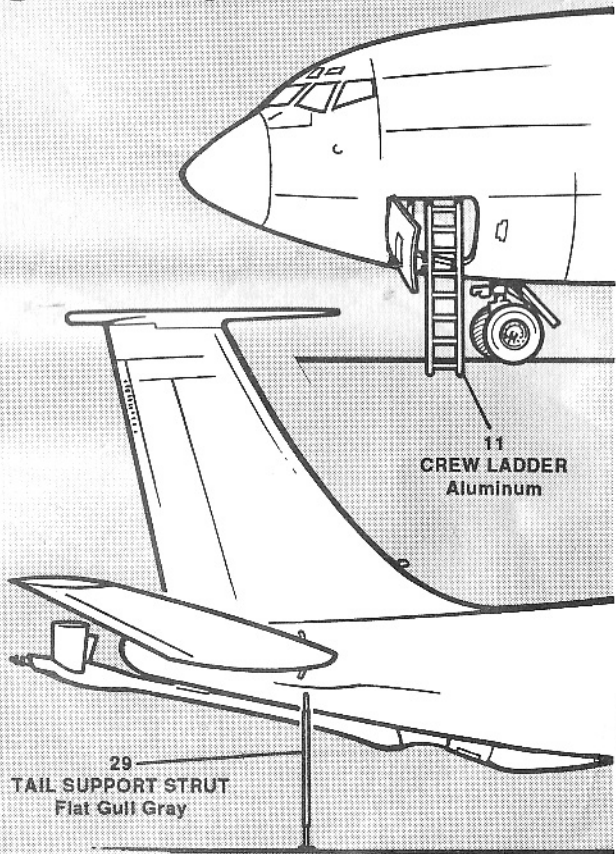



# KC 135A STRATOTANKER "JAVELINA"



Stock No. 8848

- DECALS**
- Choose the decals you want to put on your kit and use a seissors to cut it from the decal sheet.
  - Dip the decal in a cup of luke warm water for about fifteen seconds to loosen the decal from the backing paper.
  - Place the decal in position and slide the decal off the backing paper and onto the model.
  - Use a soft, damp cloth to gently rub away any water bubbles under the decal.

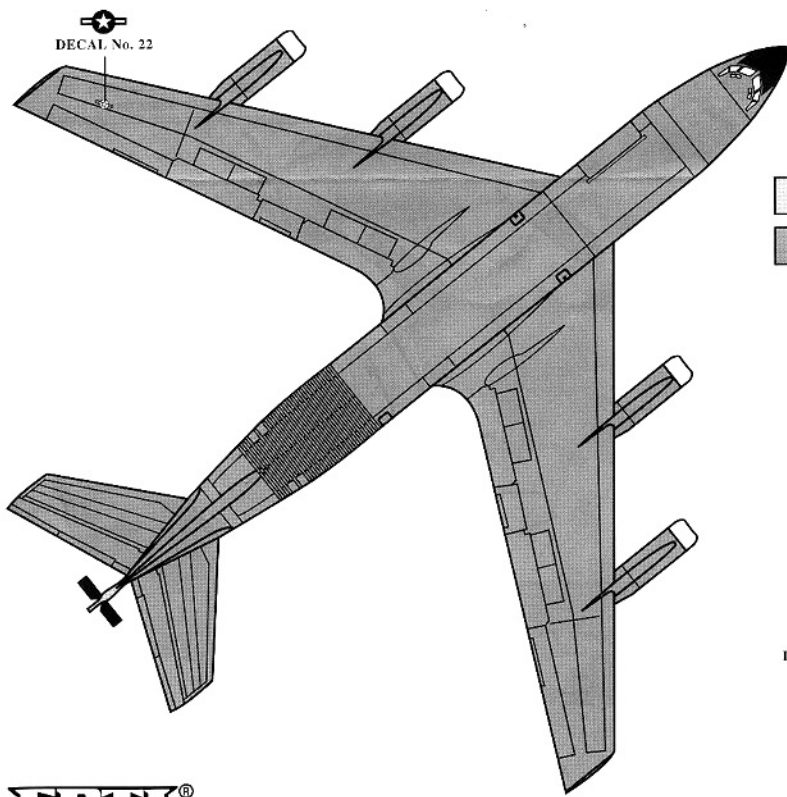
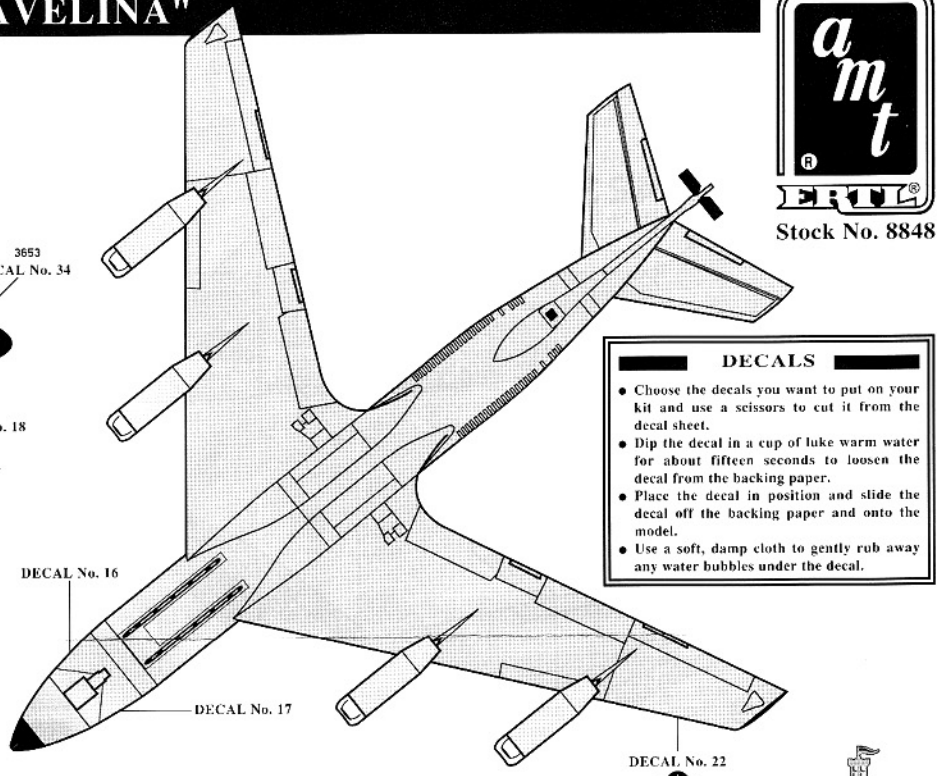
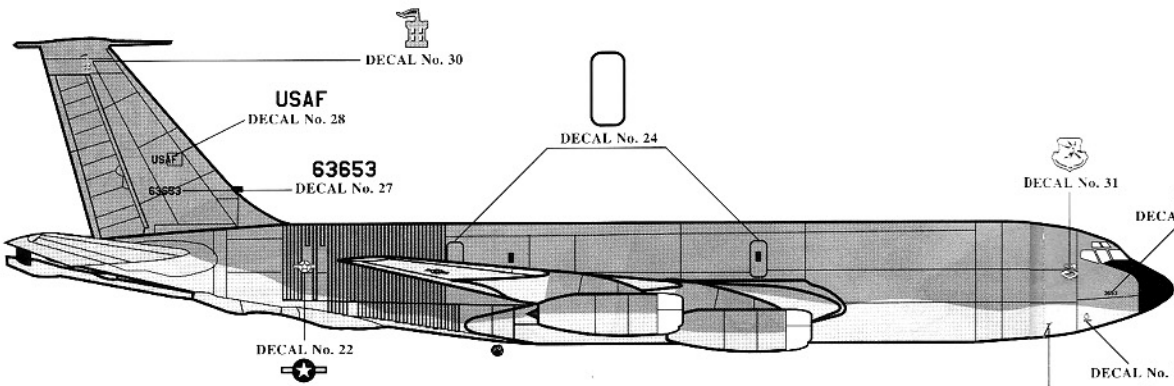

- |  |                       |  |               |
|--|-----------------------|--|---------------|
|  | Light Gray FS 16473   |  | Flat Black    |
|  | Gunship Gray FS 36118 |  | Natural Metal |

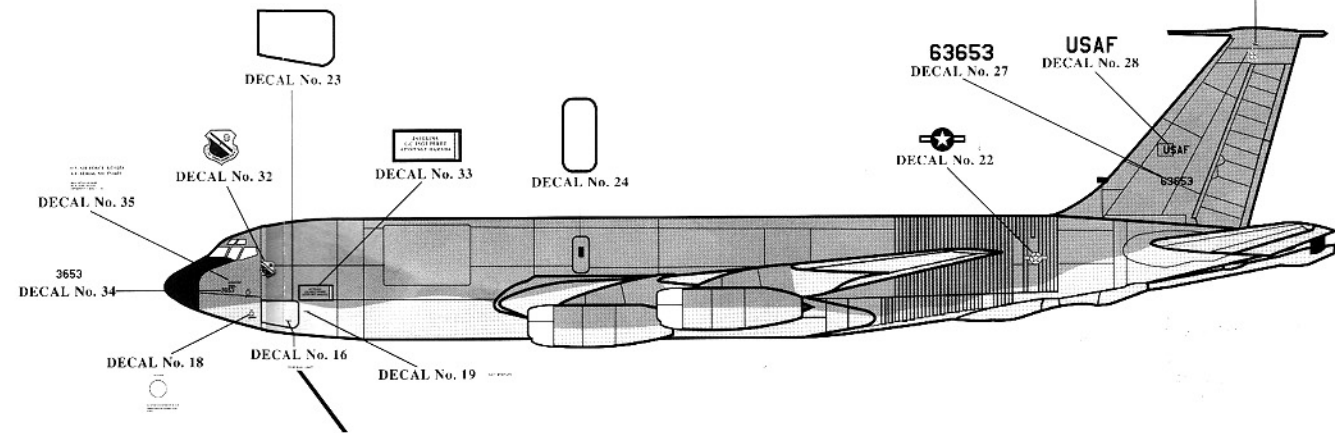

# KC 135A STRATOTANKER "EYORE"



Stock No. 8848

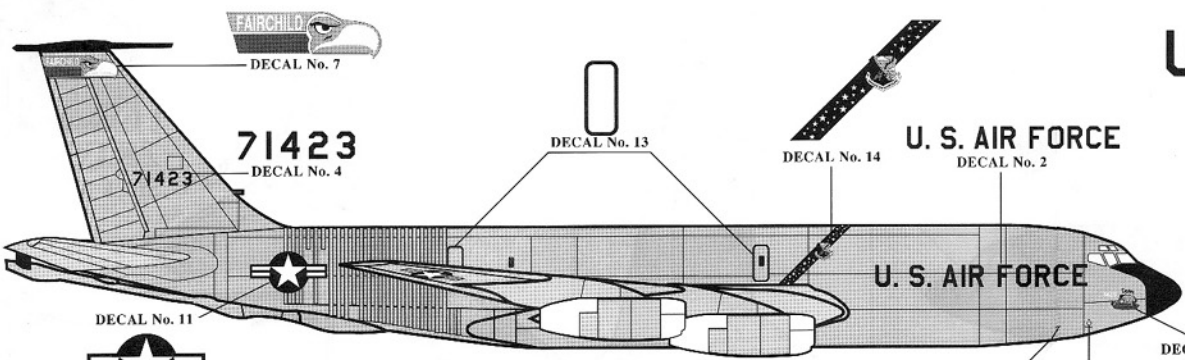



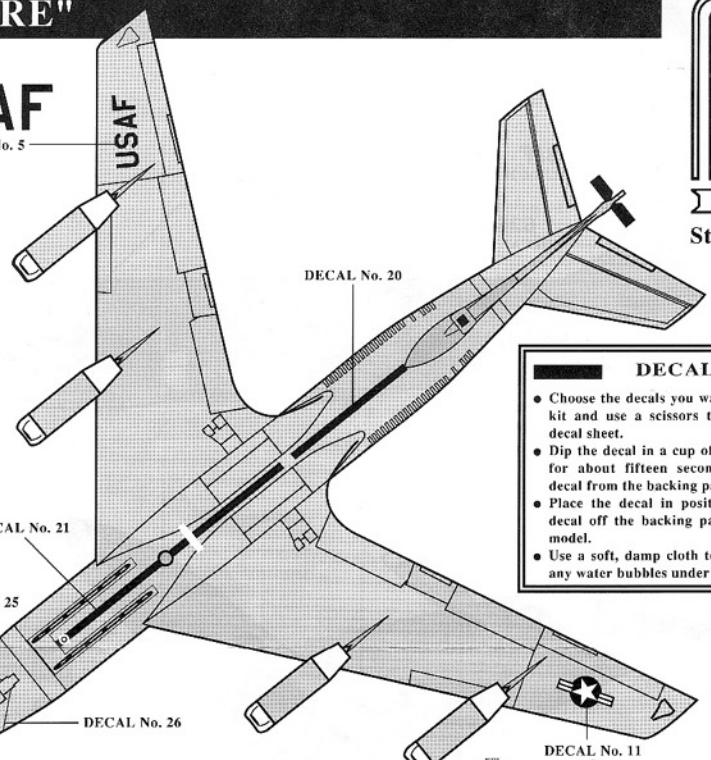

**USAF**  
DECAL No. 5

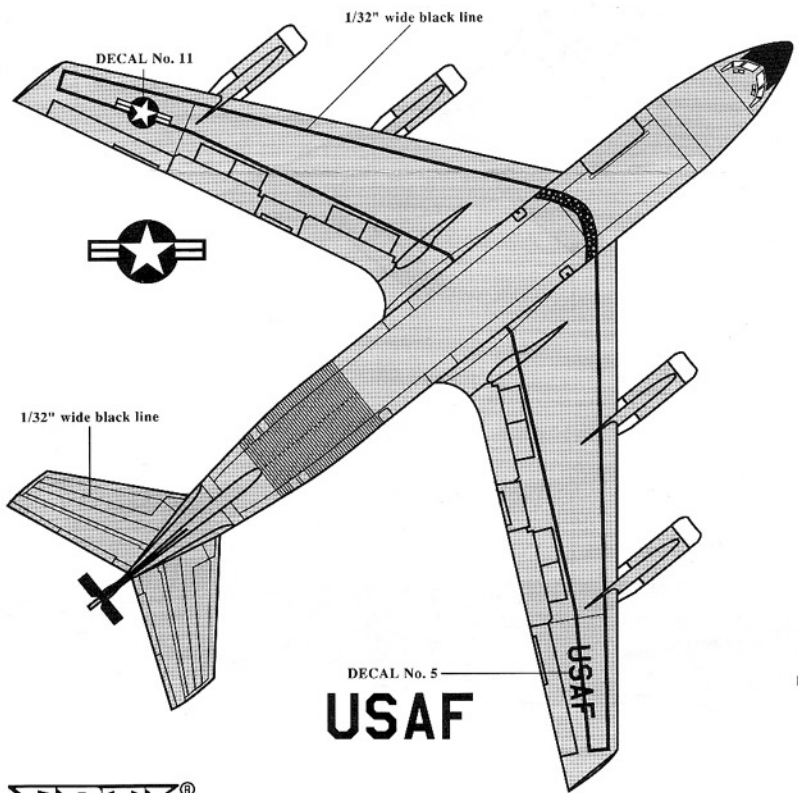

**DECALS**

- Choose the decals you want to put on your kit and use a scissors to cut it from the decal sheet.
- Dip the decal in a cup of luke warm water for about fifteen seconds to loosen the decal from the backing paper.
- Place the decal in position and slide the decal off the backing paper and onto the model.
- Use a soft, damp cloth to gently rub away any water bubbles under the decal.



-  Light gray FS 16473
-  Flat black
-  Natural metal

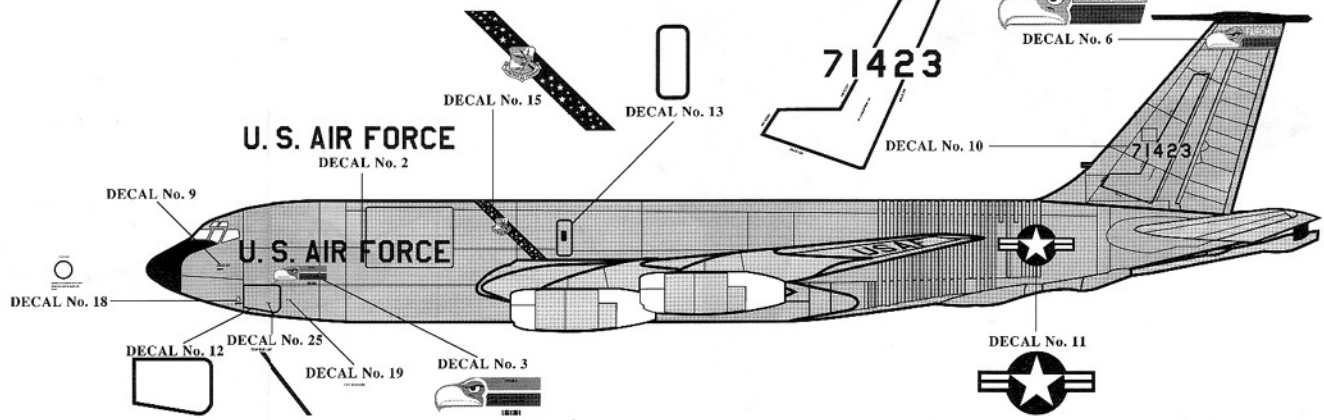

# U.S. AIR FORCE

# U.S. AIR FORCE



4 71423

# USAF

# USAF

28 USAF  
28 USAF  
71423



34 3653  
35 3653



33

JAVELINA  
CIC TSOT PEREZ  
ADIST SOT MANADA

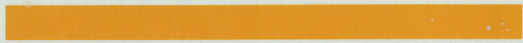

20



31



32



26

17



8



9

22

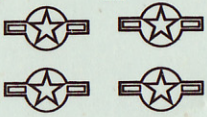

11



21

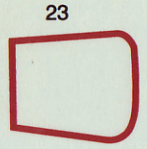
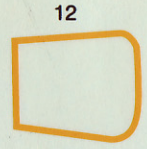

1

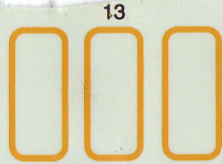

24



14

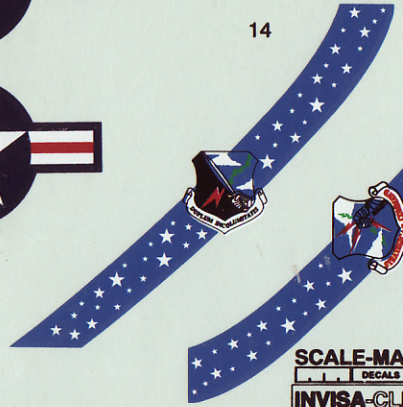

15

SCALE-MASTER®  
DECALS  
INVISIBLE-CLEAR®

16

25