

# Messerschmitt Bf 109G-14

MINISTRY of SMALL AIRCRAFT PRODUCTION

Bf 109G-14, W.Nr 16224, of an undetermined unit. This aircraft is finished in mid-war colours consisting of grey-green 74 and grey-violet 75 with light blue 76 undersurfaces. The spinner is black-green 70 with a white spiral. Note that this machine does not have an antenna mast.

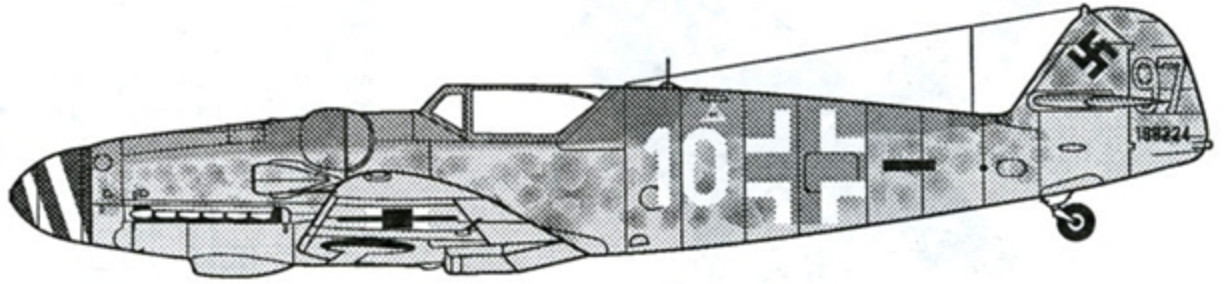

Bf 109G-14, W.Nr 464549, of an undetermined unit, Munich, 1945. This aircraft is also finished in mid-war colours consisting of grey-green 74 and grey-violet 75 with light blue 76 undersurfaces. The spinner is black-green 70 with a white spiral, and the nose aft of the spinner appears to be yellow. Note that this machine does not have an antenna mast, and has the late style fin and rudder.

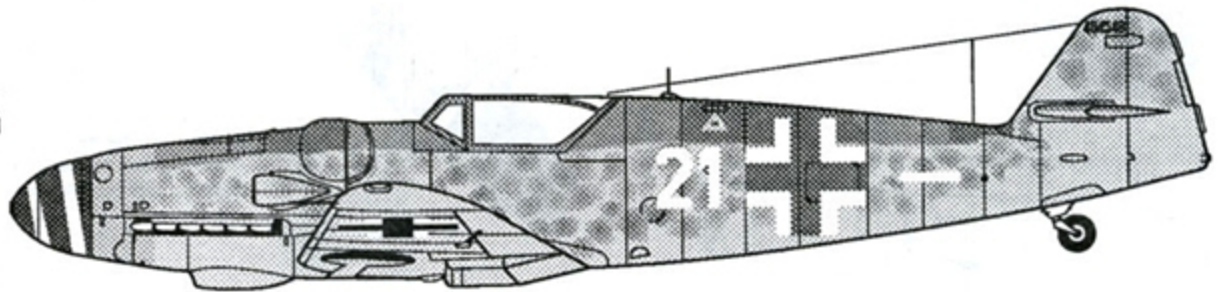

Bf 109G-14 of the Aeronautica Nazionale Repubblicana flown by Magg. Carlo Miani, II<sup>o</sup> Gr. C., December 1944. This aircraft is in standard grey-green 74/grey-violet 75/light blue 76 finish. Exhaust staining is quite heavy, carrying back along the fuselage sides and down aft of the wing root. Spinner is black-green 70 with a white spiral. RSI fasces insignia are carried on the wing uppersurfaces.

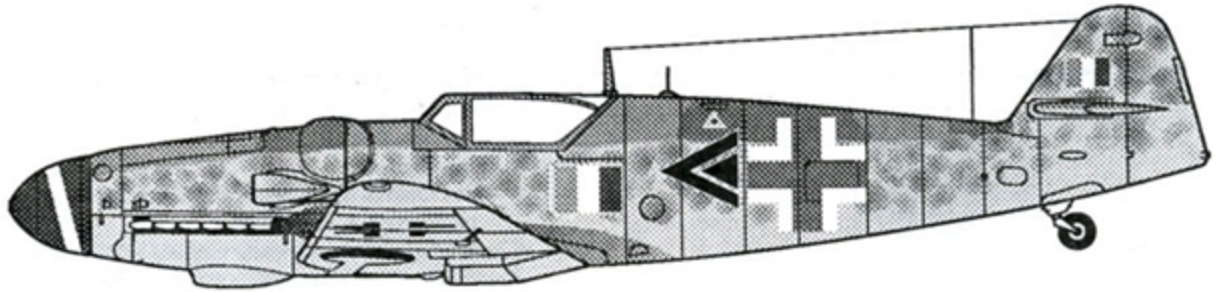

Bf 109G-14 of Lt. Ewald, 7/ JG 52, December 1944. Aircraft is in mid-war colours of grey-green 74, grey-violet 75 and light blue 76. The spinner is black-green 70 with a white spiral.

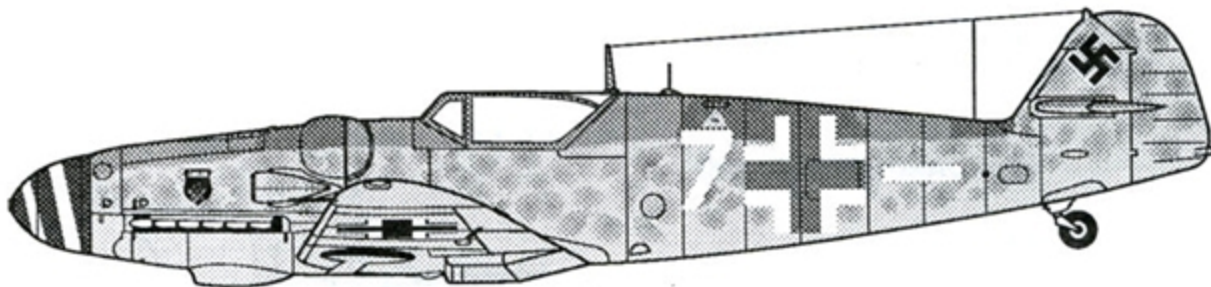

Bf 109G-14, W.Nr 782192, of JG 53. Aircraft appears to be finished in a late-war combination of brown-violet 81 and dark green 82 with light blue 76 undersurfaces. The spinner is black-green 70 with a white spiral, and the band around the nose aft of the spinner is yellow.

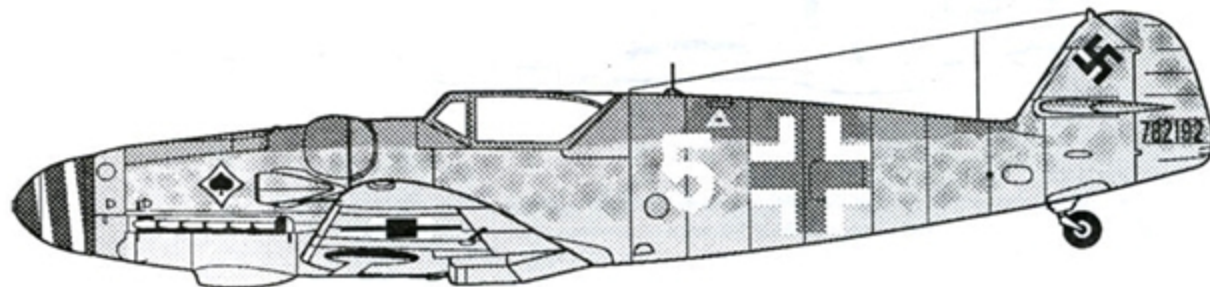



## TYPICAL CAMOUFLAGE PATTERN

### Camouflage notes:

The Bf 109G-14 appeared in several 'standard' finishes. Early aircraft carried the mid-war scheme, i.e. an uppersurface pattern of grey-green 74 and grey-violet 75 with the undersurface of wings and tailplane as well as the fuselage sides finished in light blue 76. The fuselage sides were further camouflaged with a sprayed mottling of grey 74, RLM grey 02 and black green 70. Late war finishes replaced the 74/75 pattern with one of brown-violet 81 (darker tone) and bright green 82 or dark green 83, the 76 undersides being retained.

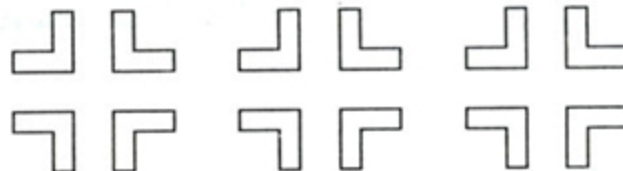

TEMPLATES FOR PAINTING IN FUSELAGE CROSSES

To ensure a perfect colour match, fill in the fuselage crosses on your model with the same colour (grey-green 74 or brown-violet 81) used to paint the rest of the model. Using these templates cut a mask from frisket or your preferred masking materia, carefully position on the model and spray the fill colour. With the white cross applied on top of the painted area you will have a most realistic looking insignia.

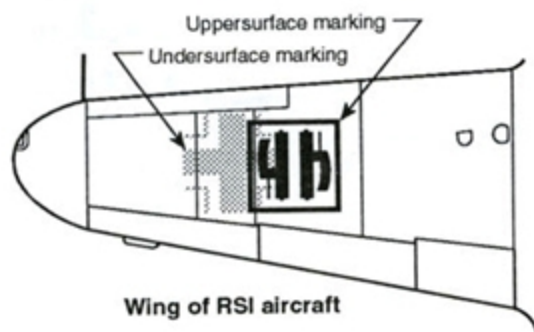
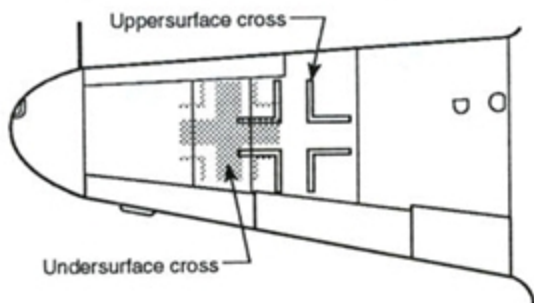
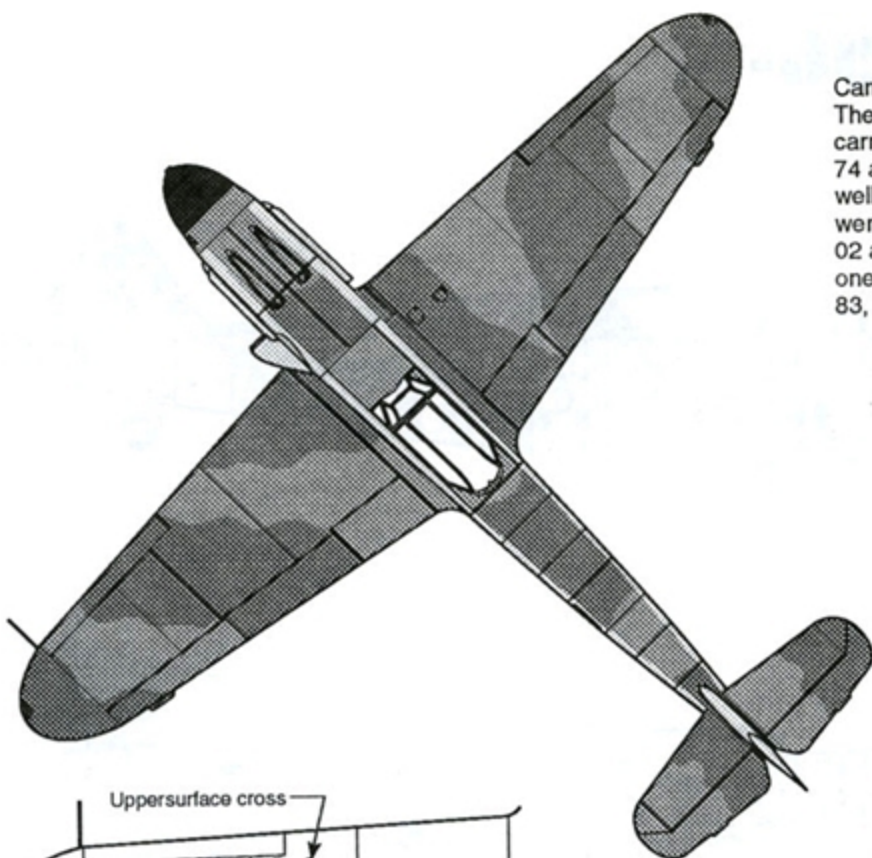

Wing of RSI aircraft

### REFERENCES

References on the Bf 109 and its sundry camouflage schemes and markings abound. Among those most useful for building and finishing the aircraft on this decal sheet are the following:

- 1 - Messerschmitt Bf 109 in Action, part 2 (Squadron/Signal #1057)
- 2 - The Messerschmitt 109 in Italian Service 1943-1945, by D'Amico & Valentini
- 3 - German Aircraft Markings 1939-1945, by K.A. Merrick
- 4 - The Modeller's Luftwaffe Painting Guide, by Smith, Pentland, & Lutz
- 5 - The Official Monogram Painting Guide to German Aircraft 1935-1945, by Merrick & Hitchcock
- 6 - Aircraft of the Luftwaffe Fighter Aces, vols. 1 & 2, by Bernd Barbas
- 7 - Model Art - Messerschmitt Bf 109G/K
- 8 - Monogram Close-Up #7, Bf 109G part 2, by T.H. Hitchcock
- 9 - Fighter Pictorials, Broken Eagles #2 & 3,
- 10 - Messerschmitt Bf 109F,G & K Series, by Prien & Rodeike
- 11 - Camouflage & Markings of the Luftwaffe, Vol. 1, Model Art Co. Ltd.
- 12 - Messerschmitt Bf 109G/K, Model Art Co. Ltd.

### KITS

At present the available 1/48 Bf 109G-14 kit is the example from Hobbycraft.

### STANDARD STENCILLING

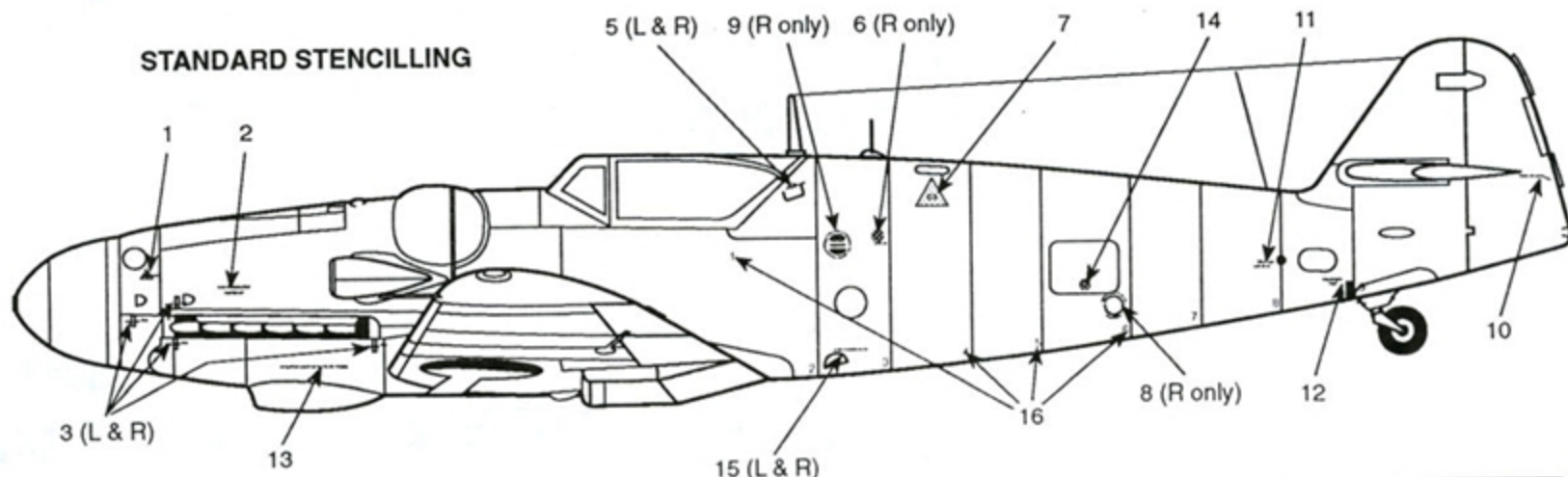

### Stencilling Note:

While aircraft may have rolled out of the factory bearing a full array of stencilling, photographs show that machines in the field rarely did. After frequent repaintings and touch-ups obliterated stencilling was often not reapplied, and many operational aircraft carried little more than the basic fueling and replenishment markings. Study photographic references carefully.

MINISTRY of SMALL AIRCRAFT PRODUCTION

Box 94, Stn. A Hull, Québec J8Y 6M7 Canada