

P-61 Black Widow

The Northrop P-61, was shrouded in secrecy from its inception. Known as the "BLACK WIDOW", it was the first U.S. aircraft designed exclusively as a night fighter. The P-61 was the heaviest aircraft to ever bear the designation "P" for pursuit, with its initial weight of over 27,400 pounds. Specifications of the WIDOW were those of a medium bomber, with a wing span of 66 feet and overall length of 48 feet 11 inches. Two Pratt and Whitney R-2800 engine powered the P-61A developing initially 1600 horsepower each. The P-61B had two R2800-65 engines, with an increased horsepower of 2200 each. Top speed of this aircraft was over 370 miles an hour.

The P-61 was the most advanced night fighter of its day, possessing incredible capabilities of destruction. Four .50 calibre machine guns were mounted to the dorsal turret and four 20 millimeter cannons in the ventral location on the fuselage pod. The four .50 calibre machine guns were designed initially as defensive weapons and could be controlled by any one of the three crew members, pilot, rear gunner, or radar operator who sat in the extreme rear of the fuselage pod. The dorsal gun turret could be rotated 360° and elevated to a 90° angle.

The first thirty-six P-61A's carried the dorsal turret. The remainder of the A production of 200 had the dorsal turret deleted due to a buffeting problem caused when the turret was rotated.

The P-61B was approximately 8 inches longer than the "A" model, its overall length being 49 feet 7 inches. Of the four hundred-fifty "B's" produced, only the second two hundred had the dorsal turret which was re-introduced. The buffeting problem had been lessened by redesign of the structure. The P-61B also incorporated many improvements requested by pilots who had used the P-61A in combat.

The P-61B was painted glossy black as were many of the P-61A's, although initially the P-61A was painted in the conventional olive drab over neutral gray. The P-61B, when painted glossy black, was almost invisible in the night skies.

The premier ace of World War II night fighter fame was Major Carrol C. Smith of the 418th Night Fighter Squadron stationed in the Pacific. On December 29th, 1944, Major Smith and his radar operator, Lt. Philip Porter, accomplished a feat unheard of in night fighter history as they intercepted and destroyed four Japanese aircraft in as single night with their P-61, "Times A Wastin'." With these four Japanese aircraft, destroyed off the coast of Mindoro in the Philippines, Major Smith became the highest scoring U.S. Night Fighter Ace with a total of seven kills. This accurately detailed model was designed from authentic drawings and photos taken of the P-61 at Wright Patterson Air Force Base.



* REPEAT SEVERAL TIMES
* A REPETER PLUSIEURS FOIS



* OPTIONAL PARTS
* PIECES EN OPTION



* DECAL
* DECAL COMANIE



* ALTERNATIVE ASSEMBLY
* ENSEMBLAGE ALTERNATIVE



* CEMENT TOGETHER
* A COLLER



* REMOVE AND THROW AWAY
* A RETIRER ET JETER



* DO NOT CEMENT
* NE PAS COLLER

READ THIS BEFORE YOU BEGIN

- * Study the assembly drawings.
- * Each plastic part is identified by a number.
- * In the assembly drawings, some parts will be marked by a star (★) to indicate chrome plated plastic.
- * For better paint and decal adhesion, wash the plastic parts in a mild detergent solution. Rinse and let air dry.
- * Check the fit of each piece before cementing in place.
- * Use only cement for polystyrene plastic.
- * Scrape plating and paint from areas to be cemented.
- * Allow paint to dry thoroughly before handling parts.
- * Any unused parts may be discarded.

DECAL APPLICATION INSTRUCTIONS

1. Cut desired decal from sheet.
2. Dip decal in water for a few seconds.
3. Place wet decal on paper towel.
4. Wait until decal is movable on paper backing.
5. Place decal in position on model, face up and slide backing away.
6. Press out air bubbles with a soft damp cloth.
7. Milkyness that may appear is for better decal adhesion and will dry clear. Wipe away any excess adhesive.
8. Do not touch decal until fully dry.
9. Allow the decals 48 hours to dry before applying clear coat.

NOTE: Decals are compatible with setting solutions or solvents.

LIRE CE QUI SUIT AVANT DE COMMENCER

- * Etudier les schémas de montage.
- * Chaque pièce en plastique est identifiée par un numéro.
- * Sur les schémas de montage, certaines pièces sont marquées d'une étoile (★) pour indiquer qu'elles sont en plastique chromé.
- * Pour une meilleure prise de la peinture et des autocollants, laver les pièces en plastique avec une solution détergente peu concentrée. Les rincer et les laisser sécher à l'air.
- * Vérifier que chaque pièce s'ajuste bien avant de la coller en place.
- * N'utiliser que de la colle pour polystyrène.
- * Gratter les parties à coller pour enlever le chrome et la peinture.
- * Laisser la peinture bien sécher avant de manipuler les pièces.
- * Toute pièce inutilisée peut être jetée.

DIRECTIVES D'APPLICATION DES AUTOCOLLANTS

1. Découper l'autocollant désiré de la feuille.
2. Tremper l'autocollant dans de l'eau pendant quelques secondes.
3. Placer l'autocollant mouillé sur une serviette en papier.
4. Attendez que l'autocollant puisse être déplacé sur son support en papier.
5. Mettre l'autocollant en position sur le modèle face sur le dessus et faire glisser le support pour l'enlever.
6. Appuyer avec un chiffon doux humide pour éliminer les bulles d'air.
7. La substance laiteuse qui peut apparaître est destinée à améliorer l'adhésion de l'autocollant et devient incolore au séchage. Essuyer pour enlever tout excédent d'adhésif.
8. Ne pas toucher l'autocollant tant qu'il n'est pas bien sec.
9. Laisser l'autocollant sécher pendant 48 heures avant d'appliquer une couche transparente.

REMARQUE: Les autocollants sont compatibles avec les solutions de fixation ou les solvants.

This optional paint guide is provided if you choose to detail paint your model.

Ce guide de peintures vous sera fourni si vous choisissez de peindre votre modèle en détail.

| | |
|-----------------|---------------|
| Aluminum | Aluminium |
| Bright Red | Rouge clair |
| Dark Tan | Havane foncé |
| Emerald Green | Vert émeraude |
| Flat Black | Noir mat |
| Flesh | Chair |
| Gray | Gris |
| Gold | Or |
| Gunmetal | Bronze |
| Light Tan | Havane clair |
| Neutral Gray | Gris neutre |
| Olive Drab | Gris vert |
| Satin White | Blanc satiné |
| Semigloss Black | Noir satiné |
| Yellow | Jaune |
| Zinc Chromate | Vert de zinc |

If you have any questions or comments, call our hotline at: **(800) 833-3570**
or, please write to:

Revell Inc Consumer Service Department, 1850 Howard Street Unit A, Elk Grove Village, Illinois 60007
Be sure to include the plan number (85754610200), part number, description, your return address and phone number.

Visit our website: www.revell.com

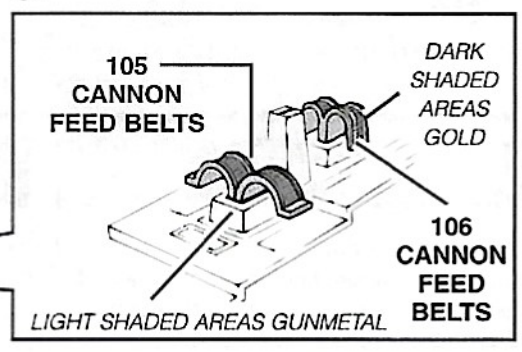
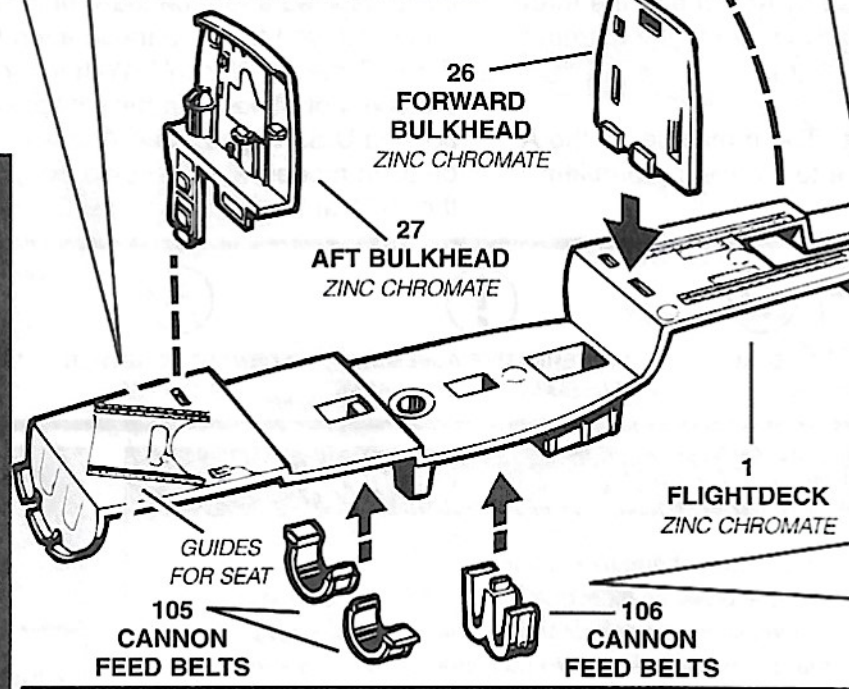
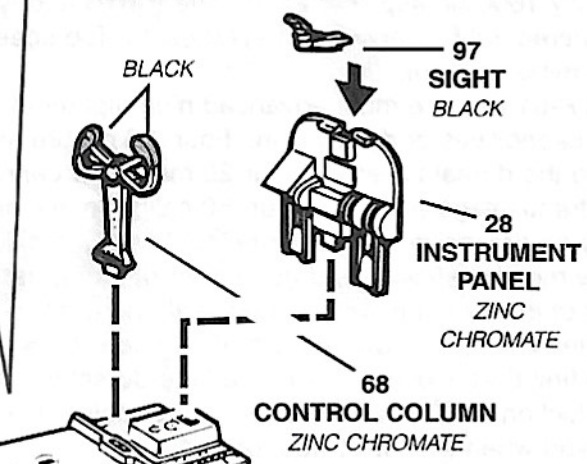
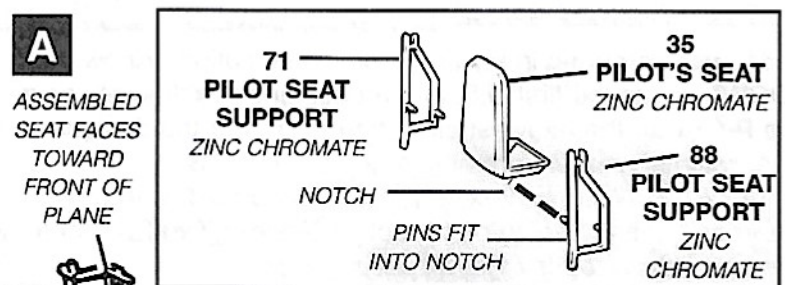
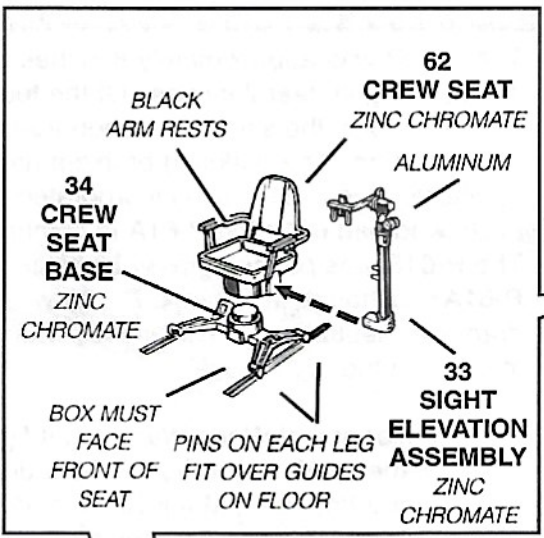
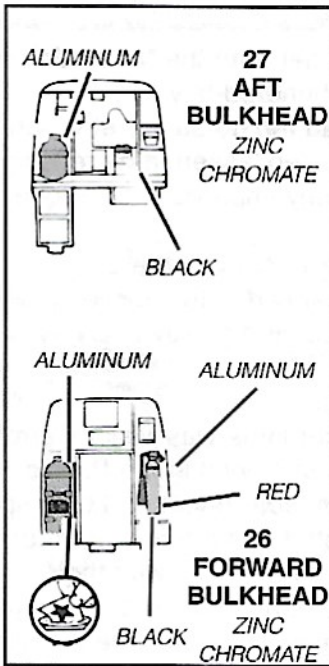

NOTE: COCKPIT ASSEMBLY

1. CEMENT PIECES 26, 27 AND 68 INTO FLOOR.
2. CEMENT SIGHT 97 INTO INSTRUMENT PANEL 28, THEN PANEL INTO FLOOR.
3. CEMENT PILOT'S SEAT TOGETHER USING PIECES 35, 71 AND 88. THEN CEMENT SEAT INTO FLOOR.

FOR ALL VERSIONS EXCEPT FOR "A" (BLACK) VERSION NO TOP TURRET

1. CEMENT PARTS 34 AND 62 TOGETHER.
2. CEMENT SIGHTING POST 33 TO ARM AND SIDE OF SEAT.
3. REPEAT FOR OTHER SEAT.
4. CEMENT SEATS ONTO GUIDES ON FLOOR - ONE SEAT MUST FACE REAR OF THE PLANE - THE OTHER MUST FACE FRONT AS SHOWN.
5. CEMENT TWO FEED CHUTE PARTS 105 INTO NOTCH IN FLOOR AS SHOWN.
6. CEMENT CHUTE PART 106 INTO OTHER NOTCH.

FOR "A" (BLACK) VERSION NO TOP TURRET

1. DO NOT CEMENT SIGHTING POST 33 ONTO SEATS
2. CEMENT TWO FEED CHUTE PARTS 105 INTO NOTCH IN FLOOR AS SHOWN.
3. CEMENT CHUTE PART 106 INTO OTHER NOTCH

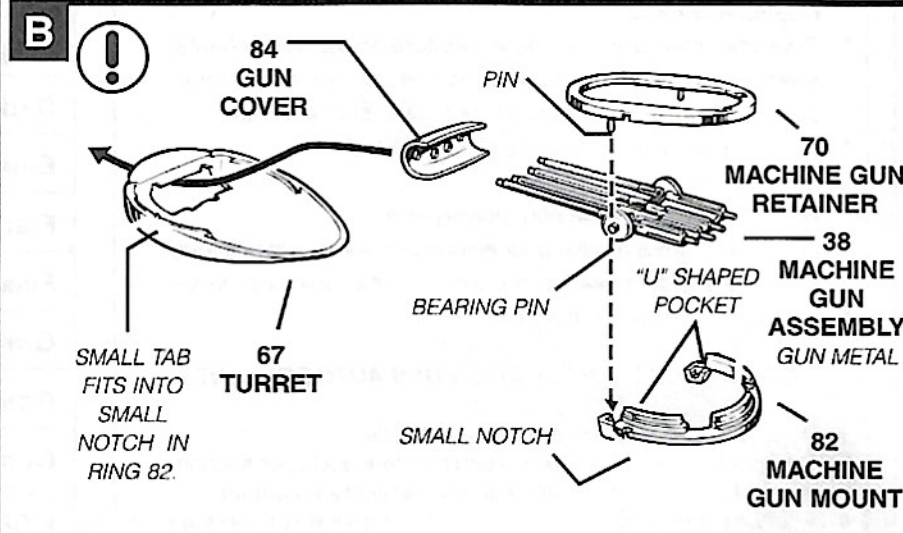

NOTE: TURRET ASSEMBLY

FOR "A" VERSION (OLIVE DRAB) WITH TOP TURRET AND "B" VERSION (BLACK) WITH TOP TURRET ("A" VERSION BLACK HAS NO TOP TURRET)

1. PLACE (DO NOT CEMENT) PINS ON GUNS 38 INTO "U" SHAPED POCKET ON RING 82.
2. WITH THE TIP OF A TOOTHPICK, CAREFULLY APPLY CEMENT ONLY TO TOP OF RIB ON RING.
3. PLACE RETAINER 70 ONTO RING.
4. SLIDE (DO NOT CEMENT) COVER 84 OVER GUNS.
5. CEMENT RING ON ASSEMBLED GUNS INTO TURRET 67 AS SHOWN.

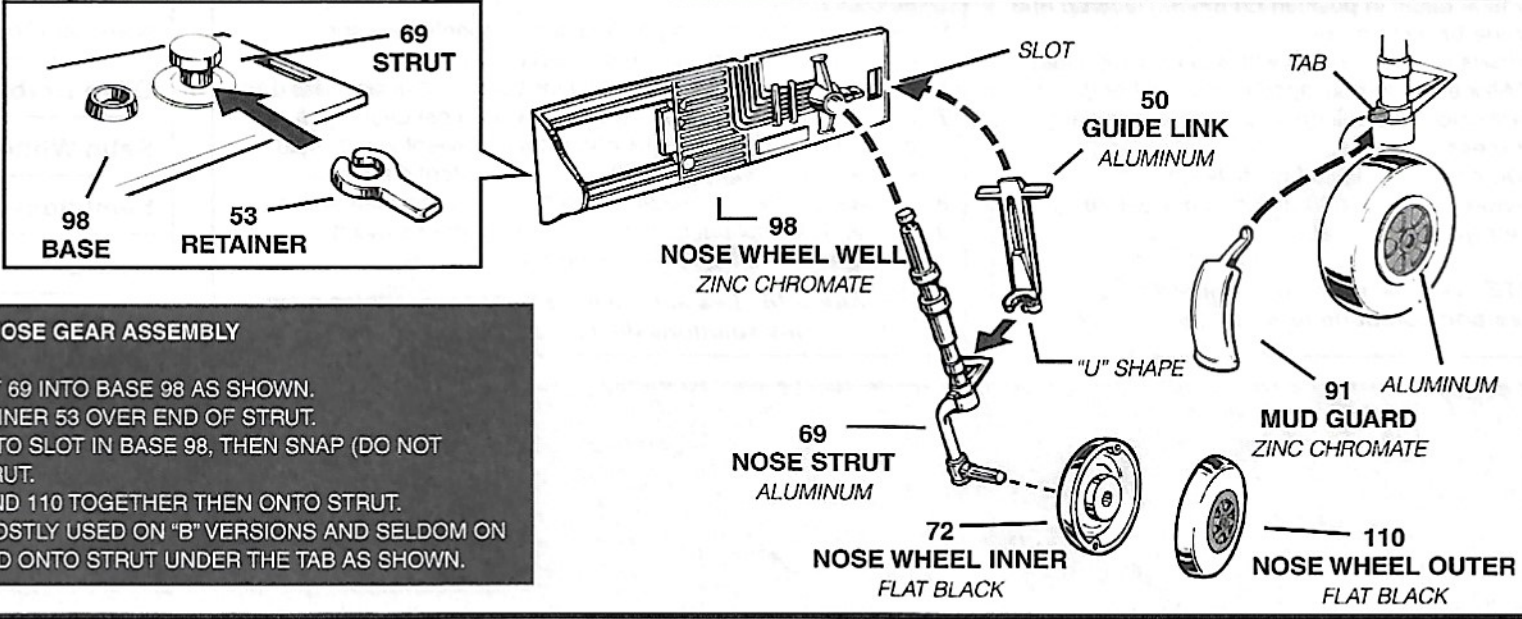

NOTE: NOSE GEAR ASSEMBLY

1. SLIP (DO NOT CEMENT) STRUT 69 INTO BASE 98 AS SHOWN.
2. SNAP (DO NOT CEMENT) RETAINER 53 OVER END OF STRUT.
3. CEMENT END OF BRACE 50 INTO SLOT IN BASE 98, THEN SNAP (DO NOT CEMENT) "U" SHAPE OVER STRUT.
4. CEMENT WHEEL HALVES 72 AND 110 TOGETHER THEN ONTO STRUT.
5. MUD GUARD (PART 91) WAS MOSTLY USED ON "B" VERSIONS AND SELDOM ON "A" VERSIONS. CEMENT GUARD ONTO STRUT UNDER THE TAB AS SHOWN.

FUSELAGE ASSEMBLY

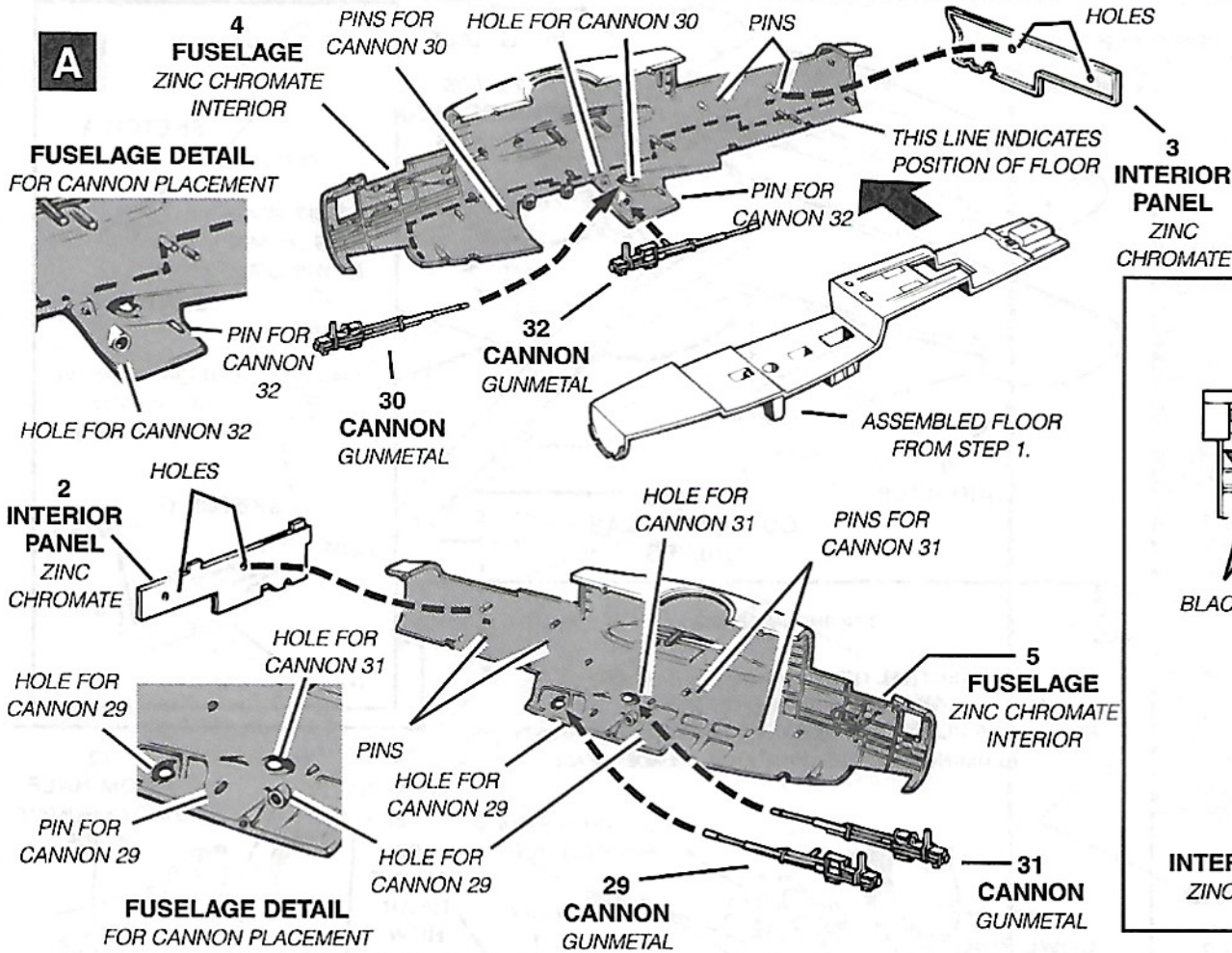

NOTE: FUSELAGE ASSEMBLY

1. CEMENT PANEL 3 ONTO FUSELAGE 4.
2. CEMENT CANNONS 30 AND 32 INTO FUSELAGE.
3. REPEAT FOR FUSELAGE 5 USING CANNONS 29 AND 31 AND PANEL 2.
4. CEMENT ASSEMBLED FLOOR (FROM STEP 1) INTO FUSELAGE AS SHOWN

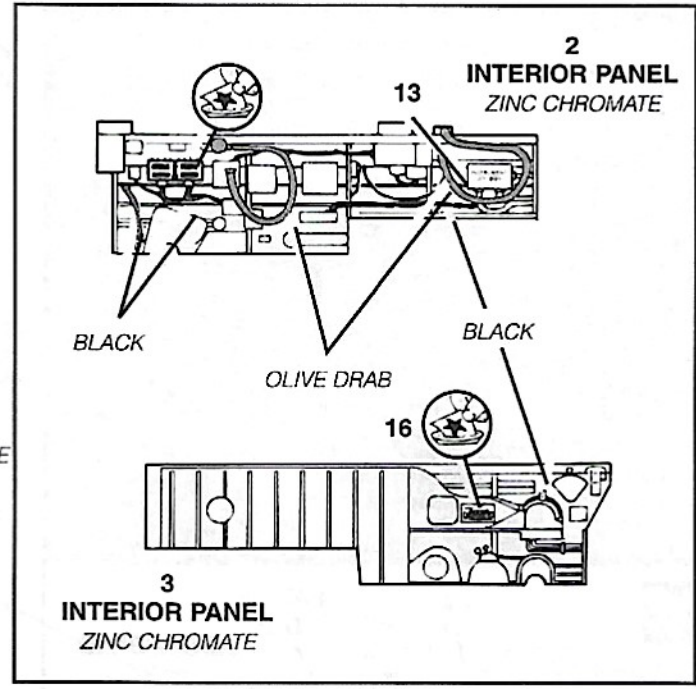

NOTE: TURRET ASSEMBLY

IF YOU ARE BUILDING A MODEL WITH NO TOP TURRET

1. CEMENT COVER 6 INTO OPENING AFTER CEMENTING FUSELAGE TOGETHER.

IF YOU ARE BUILDING A MODEL WITH A TOP TURRET

1. PLACE (DO NOT CEMENT) ASSEMBLED TURRET ONTO RIB IN OPENING.
2. CEMENT FUSELAGE HALVES TOGETHER.
3. CEMENT BASE, WITH NOSE-WHEEL, INTO FUSELAGE.

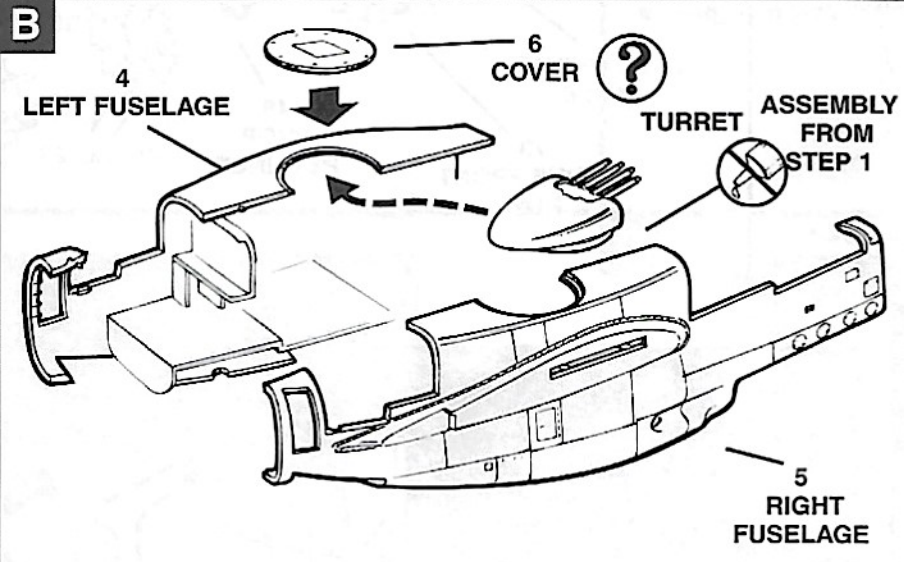

NOTE: RADAR ASSEMBLY

"A" VERSION

1. CEMENT PLATE 54 TO END OF FUSELAGE.
2. CEMENT CAPS 51 AND 55 ONTO UNIT 46, THEN CEMENT UNIT ONTO PLATE.
3. NEXT, CEMENT BRACES 57 AND 109 ONTO UNIT AND PLATE.
4. CEMENT DISH 83 ONTO BRACKET 92, THEN CEMENT BRACKET INTO UNIT.
5. NOSE (PART 58) MAY BE CEMENTED IN PLACE OR ONLY PRESSED INTO PLACE WITHOUT CEMENT SO THAT IT CAN BE REMOVED.

"B" VERSION

1. CEMENT PLATE 54 TO END OF FUSELAGE.
2. CEMENT NOSE (PART 42) TO FUSELAGE. ON THE ACTUAL AIRCRAFT, THERE WAS AN EIGHT INCH DIFFERENCE (BETWEEN "A" AND "B" VERSIONS) IN WHERE THE FUSELAGE ENDED AND THE RADOME BEGAN.

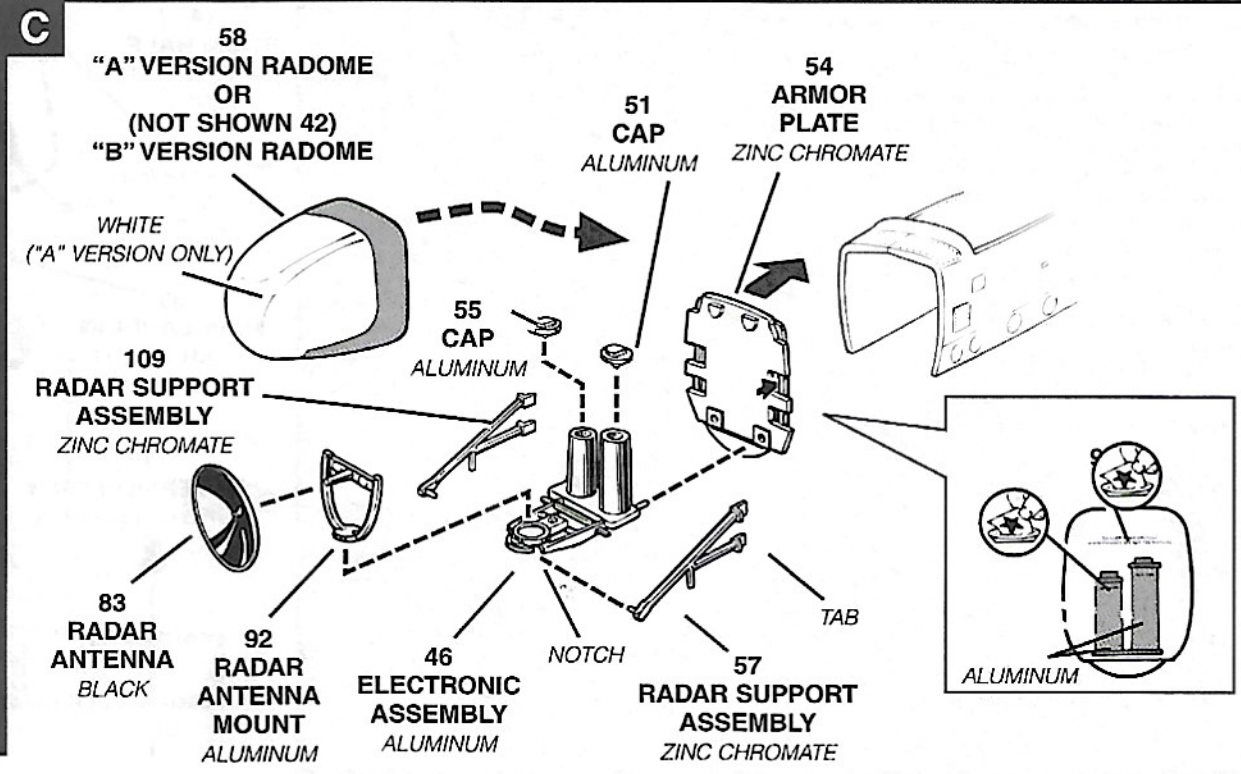

NOTE: FLAP ASSEMBLIES

"B" VERSION

1. CLEAN OUT FOUR SLOTS IN WING HALVES 7 AND 8 AS SHOWN IN SKETCH D.

ALL VERSIONS - FOR "FLAPS DOWN"

1. CEMENT FLAP HALVES 61 AND 103 TOGETHER.
2. CEMENT THREE LEGS ON FLAPS ONTO THREE PADS ON WING HALF 9 AS SHOWN IN SKETCH A.
3. NEXT, CEMENT FLAP HALVES 23 AND 25 TOGETHER, THEN CEMENT LEGS ONTO WINGS AS BEFORE.
4. CEMENT WING HALF 7 ONTO WING HALF 9.
5. REPEAT FOR WINGS 8 AND 10, FLAPS 85, 104, 22, AND 24.

ALL VERSIONS - FOR "FLAPS UP"

1. CEMENT WINGS HALVES 7 AND 9 TOGETHER.
2. CEMENT FLAP HALVES 61 AND 103 TOGETHER, THEN 23 AND 25 TOGETHER.
3. CUT OFF PORTION OF EACH LEG AS SHOWN IN SKETCH B AND C.
4. CEMENT FLAP FLUSH WITH WINGS.
5. REPEAT FOR WING HALVES 8 AND 10, FLAPS 85 AND 104, FLAPS 22 AND 24.

A

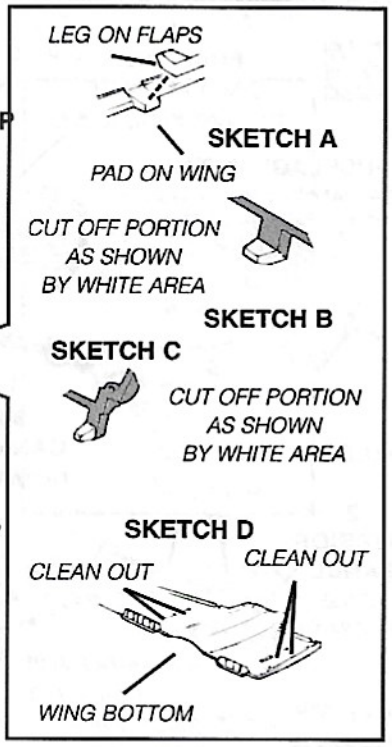
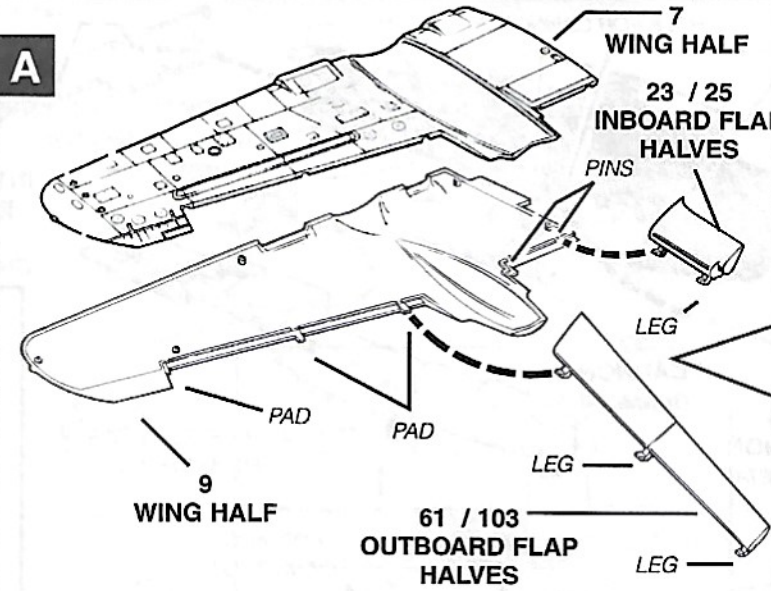

C

ENGINE PAINTING

- NEUTRAL GRAY IGNITION WIRE HARNESS
- GRAY GEAR BOX AND CRANK SHAFT
- SEMIGLOSS BLACK PUSH RODS, DISTRIBUTORS AND EXHAUST PIPES
- ALUMINUM ROCKER COVERS AND CYLINDER HEADS.

B

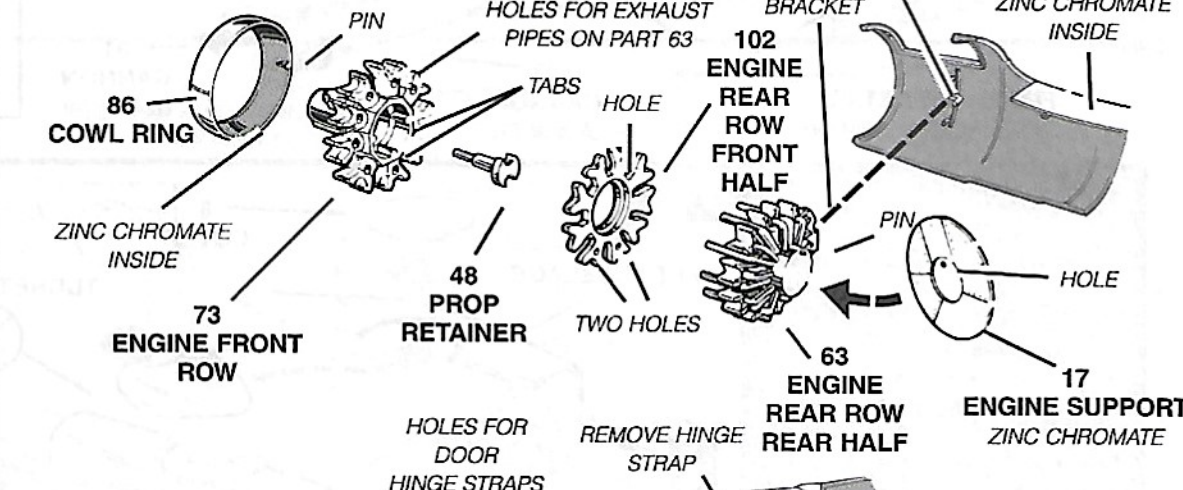
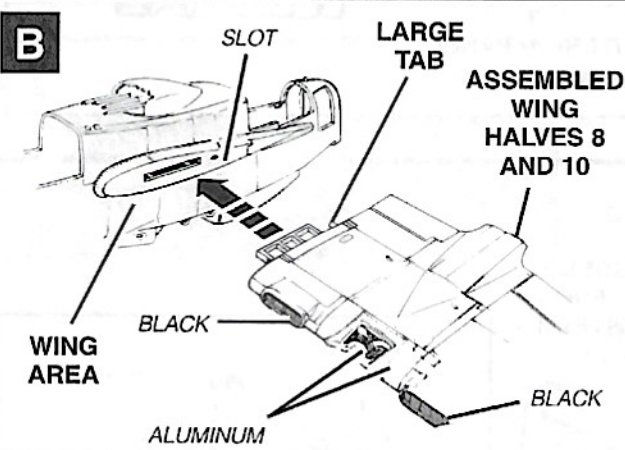

NOTE:

1. APPLY CEMENT TO WING AREA ON FUSELAGE AND TO LARGE TAB ON ASSEMBLED WING.
2. PRESS WING FIRMLY INTO PLACE. WING MUST TOUCH FUSELAGE TIGHTLY. HOLD UNTIL CEMENT DRIES.
3. REPEAT FOR OTHER ASSEMBLED WING.

NOTE: BOOM ASSEMBLIES

1. CEMENT MAIN LANDING GEAR BRACE 47 ONTO MAIN LANDING GEAR STRUT 39. PIN FITS INTO HOLE, OTHER END AGAINST LONG PIN.
2. CEMENT WHEEL HALVES 36 AND 37 TOGETHER, THEN CEMENT ONTO STRUT.
3. NEXT, CEMENT STRUT INTO BOOM HALF 14.
4. CEMENT ANTENNA 49 INTO NOTCH AS SHOWN.

"A" VERSION - RIGHT BOOM

1. CEMENT PINS ON DOOR 18 INTO BOOM.
2. CEMENT PINS ON DOOR 20 INTO BOOM HALF 13, THEN CEMENT BOOM HALVES TOGETHER.

"B" VERSION - RIGHT BOOM

1. REMOVE HINGE FROM DOOR 18 AS SHOWN AND CEMENT PIECES INTO BOOM 14 AS SHOWN.
2. OTHER DOOR 20 REMAINS UN CUT. CUT OFF HINGE STRAPS AND CEMENT DOOR FLUSH WITH BOOM 13. CEMENT BOOM HALVES TOGETHER.

"A" AND "B" VERSION - LEFT BOOM

1. USE PROCEDURE FOR RIGHT BOOM ("A" AND "B" VERSION) AND CEMENT PARTS 47, 40, 36, 37 INTO BOOM HALF 11, 19 (UNCUT FOR "A"), 19 (CUT FOR "B")
2. CEMENT ANTENNA 49 INTO NOTCH IN BOOM HALF 12. DO NOT CEMENT BOOM HALVES TOGETHER.
3. SLIP (DO NOT CEMENT) PROP RETAINER 48 INTO ENGINE FRONT ROW 73.
4. CEMENT ENGINE REAR ROW FRONT HALF 102 TO ENGINE FRONT ROW ASSEMBLY. LINE-UP THREE TABS AND NOTCHES.
5. CEMENT ENGINE REAR ROW REAR HALF 63 TO ENGINE REAR ROW FRONT HALF. EXHAUST PIPES FIT INTO HOLES. THREE PINS ON ENGINE REAR ROW REAR HALF FIT INTO THREE HOLES IN ENGINE REAR ROW FRONT HALF.
6. NEXT, CEMENT ENGINE SUPPORT 17 TO BACK OF ENGINE.
7. APPLY CEMENT TO BRACKET ON ENGINE AND PRESS INTO BOOM HALF 12.
8. DOOR 21 REMAINS UN CUT. CEMENT DOOR INTO BOOM HALF 12. "A" VERSION IS OPEN. "B" VERSION IS CLOSED (REMOVE HINGE STRAPS.)
9. NOW CEMENT BOOM HALVES TOGETHER.
10. CEMENT RING 86 TO BOOM.

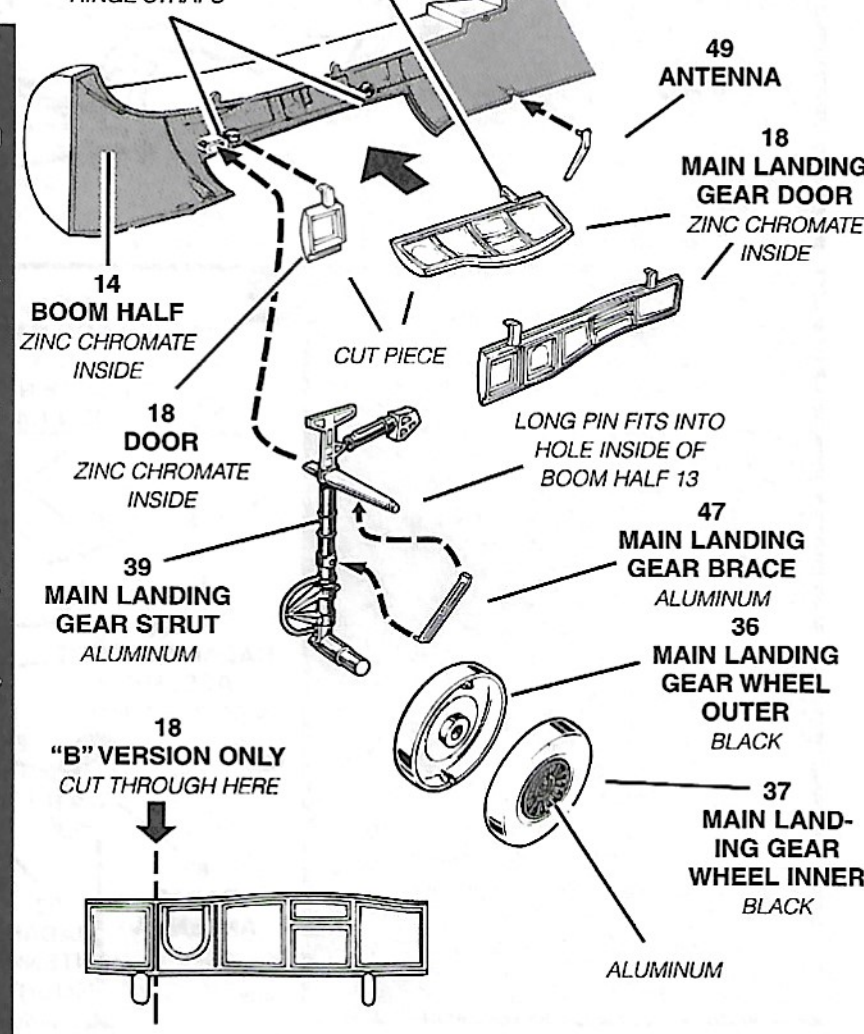

4

BOOM AND FUEL TANK ASSEMBLY

A

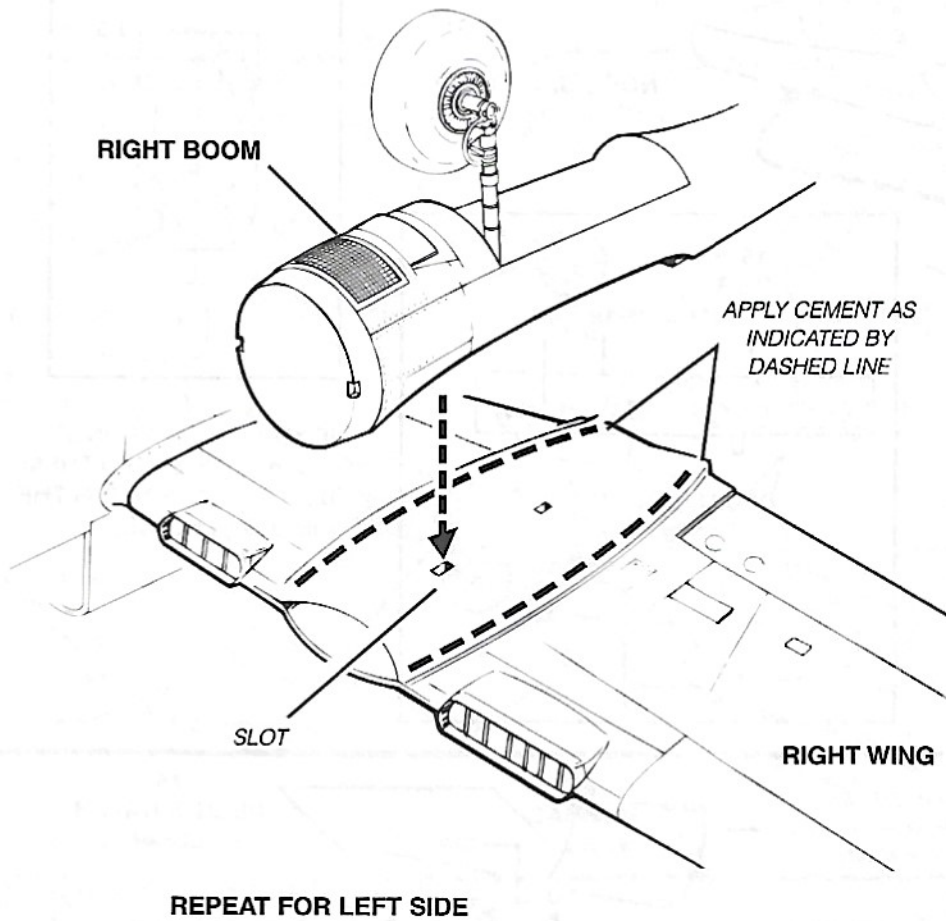

B

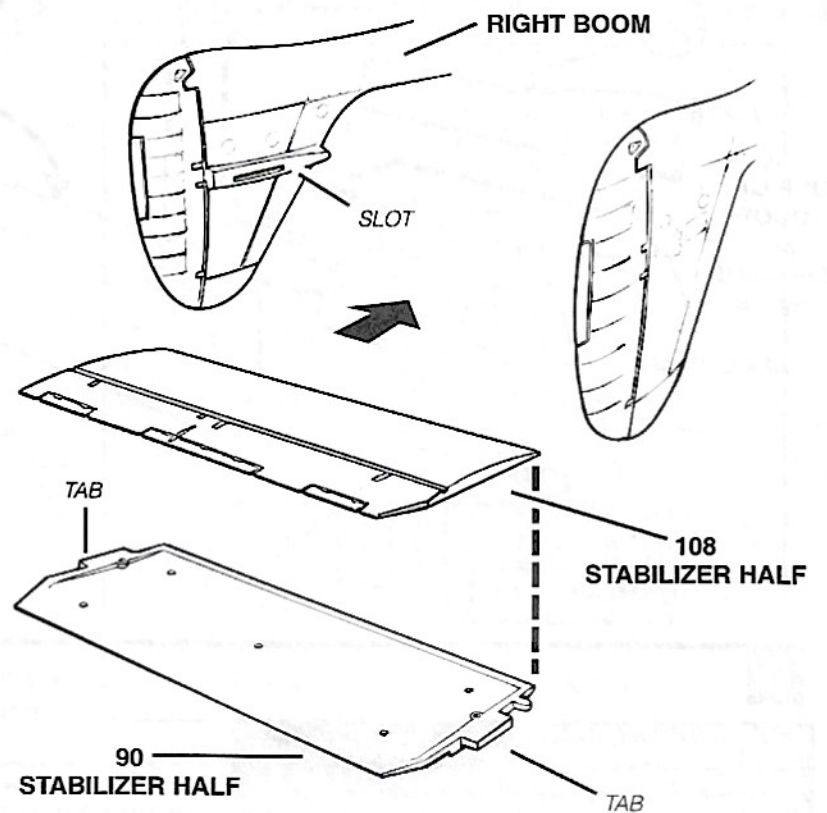

C

4X

"B" VERSION ONLY

1. CEMENT TANK HALVES 95 AND 96 TOGETHER.
2. CEMENT TANK INTO SLOTS IN WING.
3. REPEAT FOR OTHER SIDE.

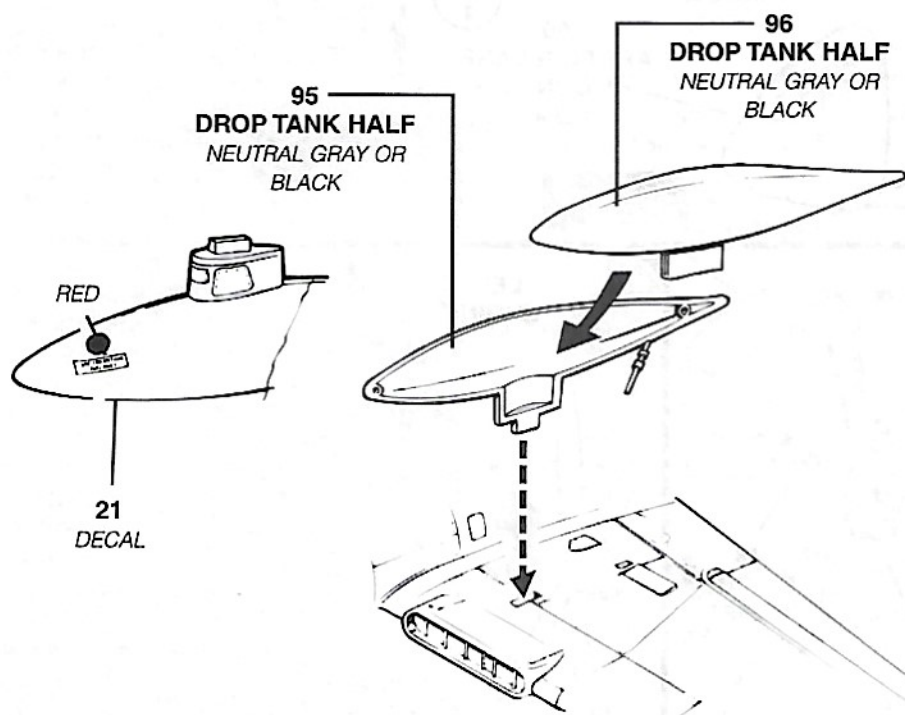

D

NOTE:

1. TWO PANELS 89 AND 93 MAY BE CEMENTED IN AN OPEN OR CLOSED POSITION. REMOVE HINGES FOR CLOSED PANELS.
2. INSPECTION PANEL 60 MAY BE LEFT OFF OR CEMENTED IN PLACE.
3. "B" VERSION - PANEL 89 MUST BE CEMENTED CLOSED.

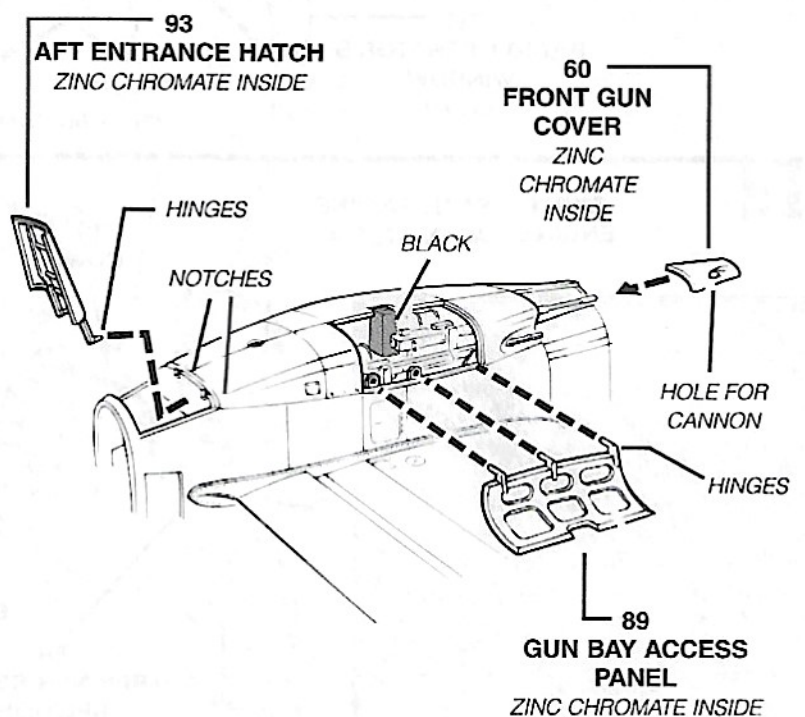

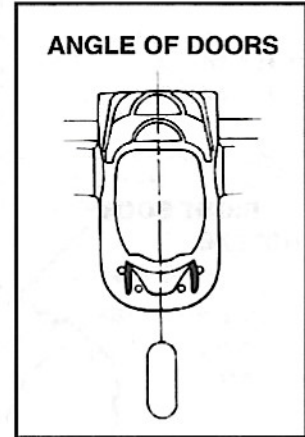
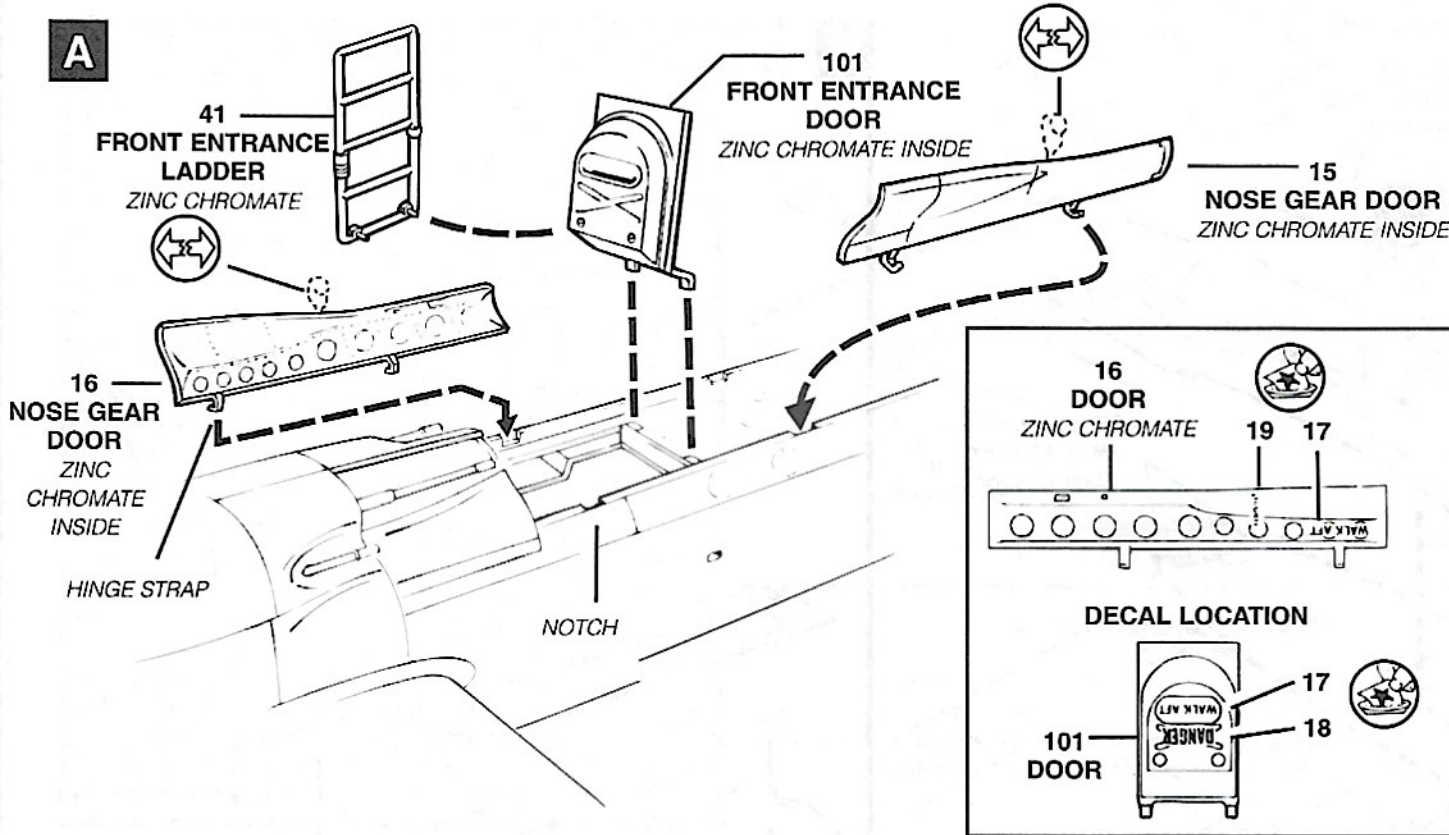

IF YOU ARE APPLYING DECALS, POSITION THEM BEFORE CEMENTING THE PIECES IN PLACE.

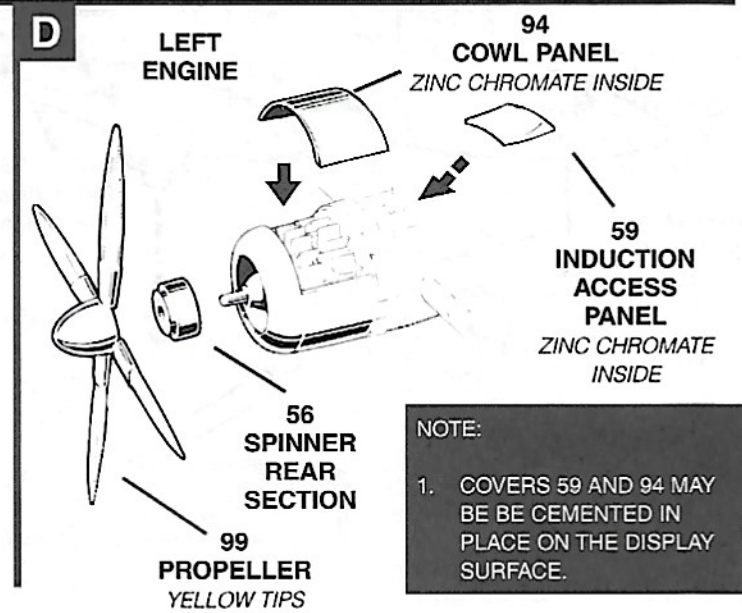
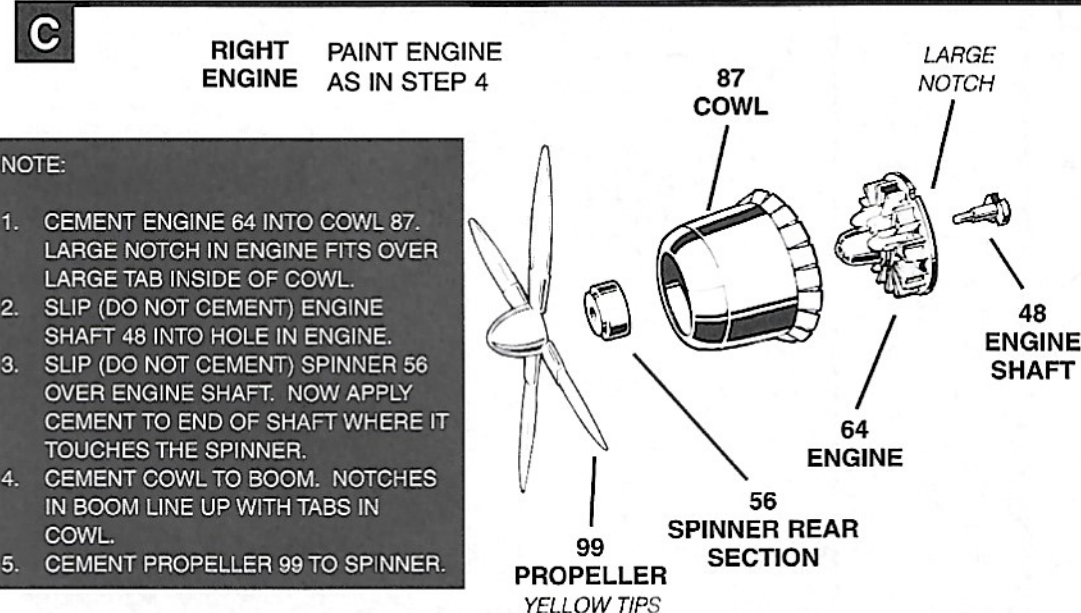
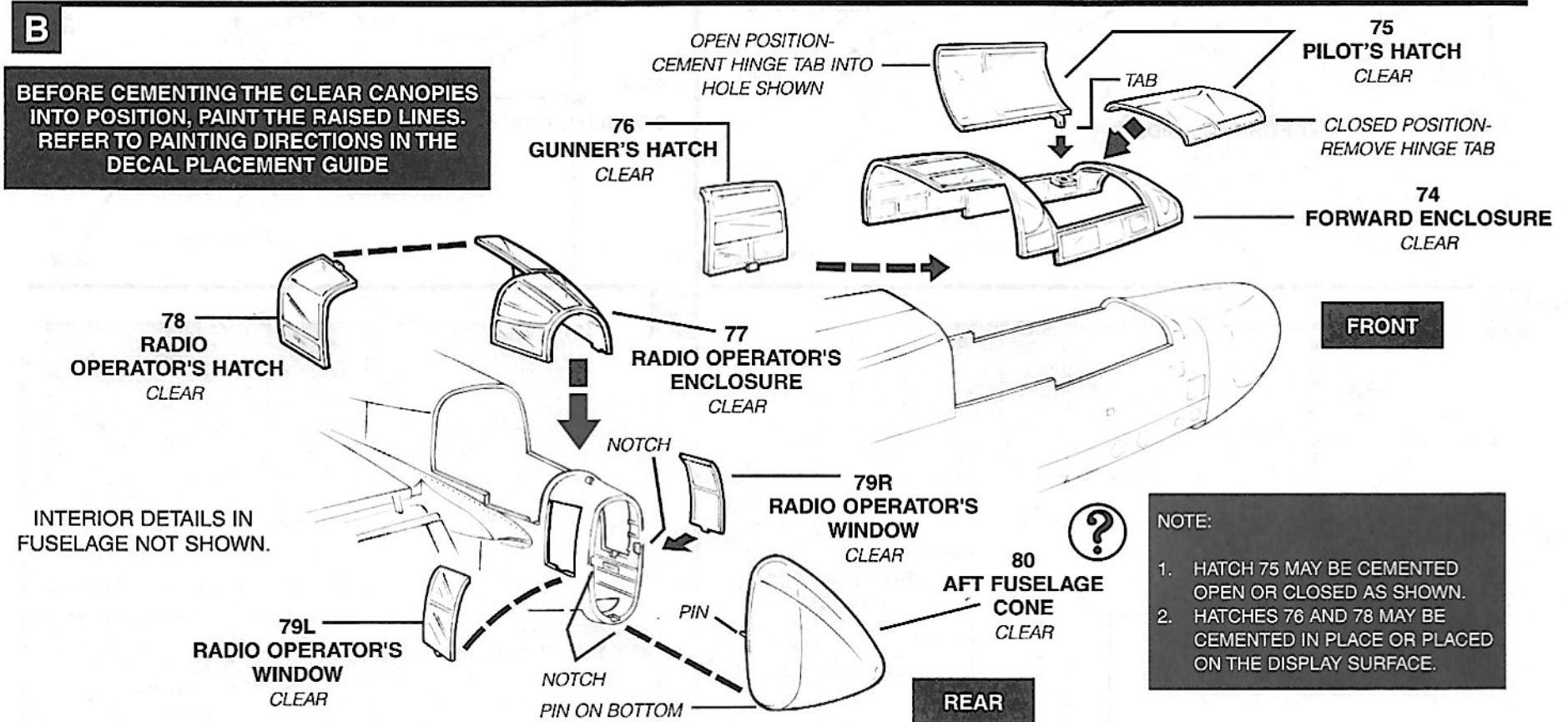

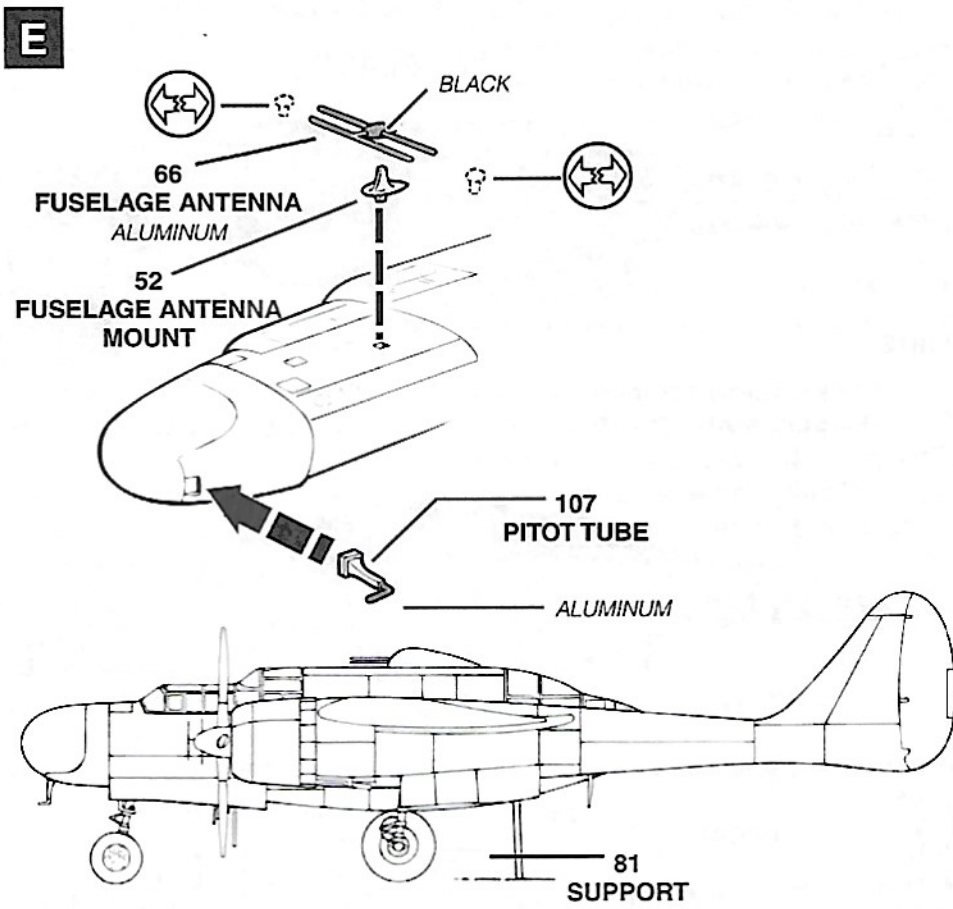

DECALS

When applying decals, refer to the drawing or photo of the specific version you have assembled. The numbers shown on the drawings are in reference to those on the decal sheet. Larger decals are easily identified for position. Before they are completely dry, decals should be firmly pressed against surface contours.

PAINTING

It is best to paint most of the parts before cementing them. The large outside surfaces such as wings and fuselages may be painted after assembly. A small pointed brush is best for painting small parts. Allow time for paint to dry thoroughly before handling parts. Scrape paint away from areas which will be cemented because cement will not hold paint.

Canopy details can be easily and neatly done by using one of the dull finish acetate mending tapes. Cut a strip about five inches long and stick it to a piece of glass or plastic, paint this strip the same color as the upper part of your model. Allow the paint to dry thoroughly. Using a straight edge and a razor blade cut strips from the tape the same width as the canopy ribs. Lift up the strips and apply over each rib on the canopy. Another method of achieving canopy realism is by masking the entire canopy with transparent tape. Use a sharp knife and very carefully cut exposed parts and allow to dry thoroughly. Remove the remaining tape from from the canopy by lifting it with the tip of your knife. Either method will result in an extremely realistic canopy.

Figures – Flesh face and hands, light tan shirt and pants, dark tan belt, flat black shoes, light or dark tan cap.

PLACEMENT GUIDE

