

# Convair 880

■ 1/126 scale

#### BRITAIN

"CAUTION: NOT SUITABLE FOR CHILDREN UNDER 3 YEARS. CONTAINS SMALL PARTS."

#### FRANCE

CERTAINS PRODUITE CONTIENNENT DES PIÈCES DE PETITE DIMENSION QUI NE CONVIENT PAS A UN ENFANT DE MOINS DE 36 MOIS.

#### GERMANY

VORSICHT: NICHT FÜR KINDER UNTER 36 MONATEN— ERTHÄLT KLEINE TEILE.

#### ITALY

PRODOTTO NON ADATTO AI BAMBINI DI ETA INFERIORE AI 36 MESI. CONTIENE PICOLLO OGGETTI.

#### HOLLAND

KAN GEVAAR OPLEVEREN VOOR KINDEREN TOT 3 JAAR. BEVAT KLEINE UNDERDELEN.

#### PORTUGAL

ATENCAO: IMPRÓPRIO PARA CRIANÇAS COM MENOS DE 3 ANOS. CONTÉM PEÇAS PEQUENAS.

#### SPAIN

ATENCIÓN: NO ES CONVENIENTE PARA NIÑOS MENORES DE 3 AÑOS. CONTIENE PIEZAS PEQUEÑAS.

#### DENMARK

FORSIGTIGI IKKE EGNET TIL BORN UNER 3 AR. INDEHOLDER SMA DELE.

#### GREECE

ΠΡΟΣΟΧΗ: ΔΕΝ ΕΙΝ ΕΙΝΑΙ ΚΑΤΑΛΗΛΟ ΓΙΑ ΠΑΙΔΙΑ ΚΑΤΩ ΤΩΝ ΤΡΙΩΝ ΕΤΩΝ ΠΕΡΙΕΧΕΙ ΜΙΚΡΑ ΤΕΜΑΧΙΑ.

Although it resembles the 707 and DC-8, Convair's 880 jetliner was not intended to compete directly with these two airliners. Howard Hughes, who controlled Trans World Airlines at the time, recognized the need for a short to medium range jetliner that offered the same luxurious comforts of the larger jets. With assurances from Hughes of an order for TWA, Convair developed the 880 to carry up to 110 passengers economically on 1,200-1500 mile legs.

Initially, the new jet was called Convair Model 22 Skylark, then it was decided to paint the sleek airliner all gold and call it the Golden Arrow. This certainly would create an immediate identity for their plane, but it soon became clear that the maintenance of this unique finish would be impractical, so the name 600, for 600 mph was chosen. Perhaps the publicity department thought the number of the newest jetliner should be higher than 707 or even -8, and the designation finally selected, 880, still represents the speed of the plane, but in feet per second.

By the time the 880 first flew on January 27, 1959, TWA and Delta Airlines had ordered 40, and eventually another 25 were sold to such airlines as Northeast, Japan Air Lines and Capital, although Capital never received the plane. One aircraft, registered N880EP was owned by Elvis Presley. Unfortunately, the need for the medium-range jetliner did not grow and the production ended with the 65th plane. This does not imply that the 880 wasn't a successful aircraft. It's operators were very pleased with the performance of the plane, although it eventually became too expensive to operate as the cost of jet fuel increased. By 1975, most of the 880s were retired and many were sent to the Mojave Desert, in California, for storage. Here several have been refurbished and have been finding their way into smaller foreign companies as airliners or cargo haulers. One was converted into a tanker for refueling tests during the development of the F-18 Hornet.

*Box art by John Amendola*

GLENCOE

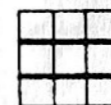

MODELS

Box 846  
Northboro  
Massachusetts  
01532  
508-869-6877



**Cement Parts**  
Coller  
Kleben  
Pegar  
Incollare  
Colar  
Kleven



**Do Not Cement Parts**  
Ne Pas Coller  
Nicht Kleben  
No Pegar  
Non Incollare  
Não Colar  
Niet Kleven



**Cut Away**  
Couper  
Scheiden  
Cortar  
Tagliare  
Cortar  
Snijden



**Optional Parts**  
Choix  
Auswahlmöglichkeit  
Eleccion  
Scelta  
Opcao  
Keuze



**3**

**Repeat Operation**  
Répéter l'opération  
Vorgang Wiederholen  
Repitir la operacion  
Repetere  
Repitir a Operação  
Herhalen

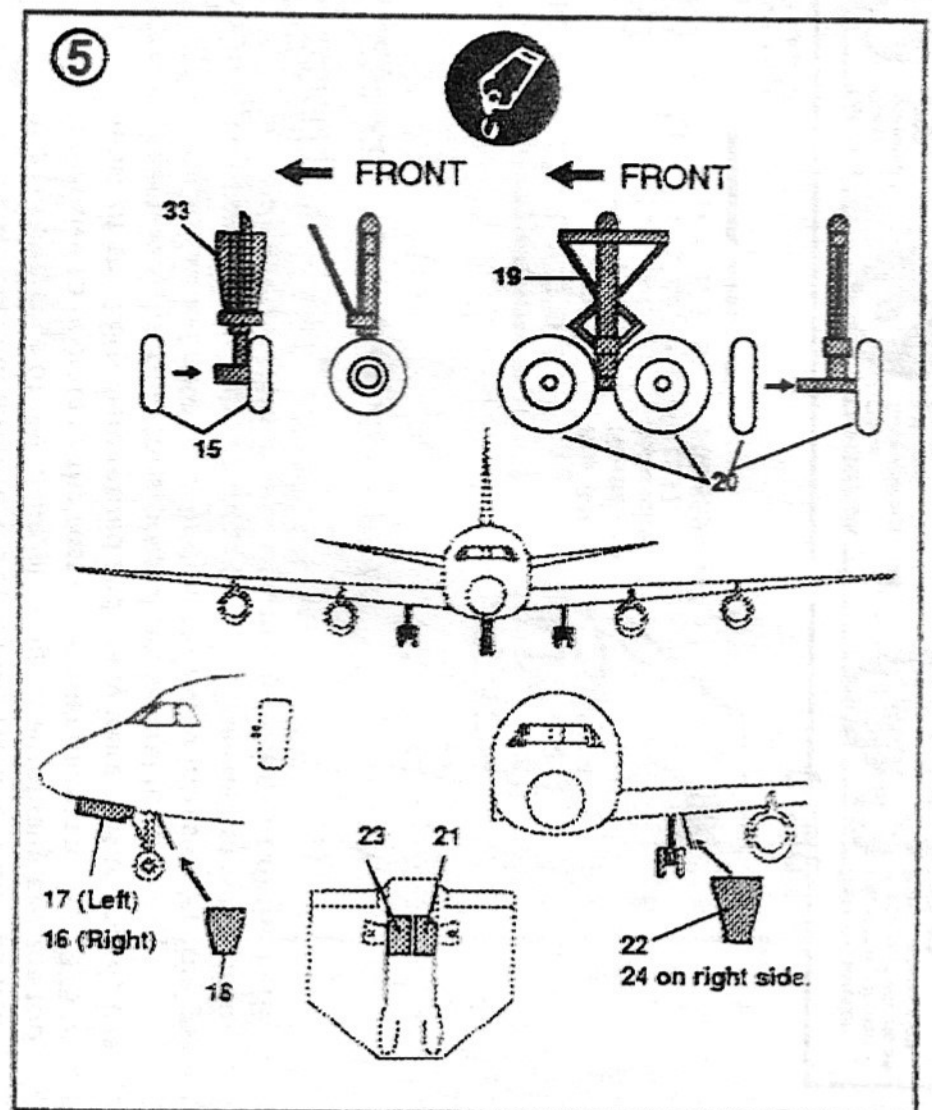
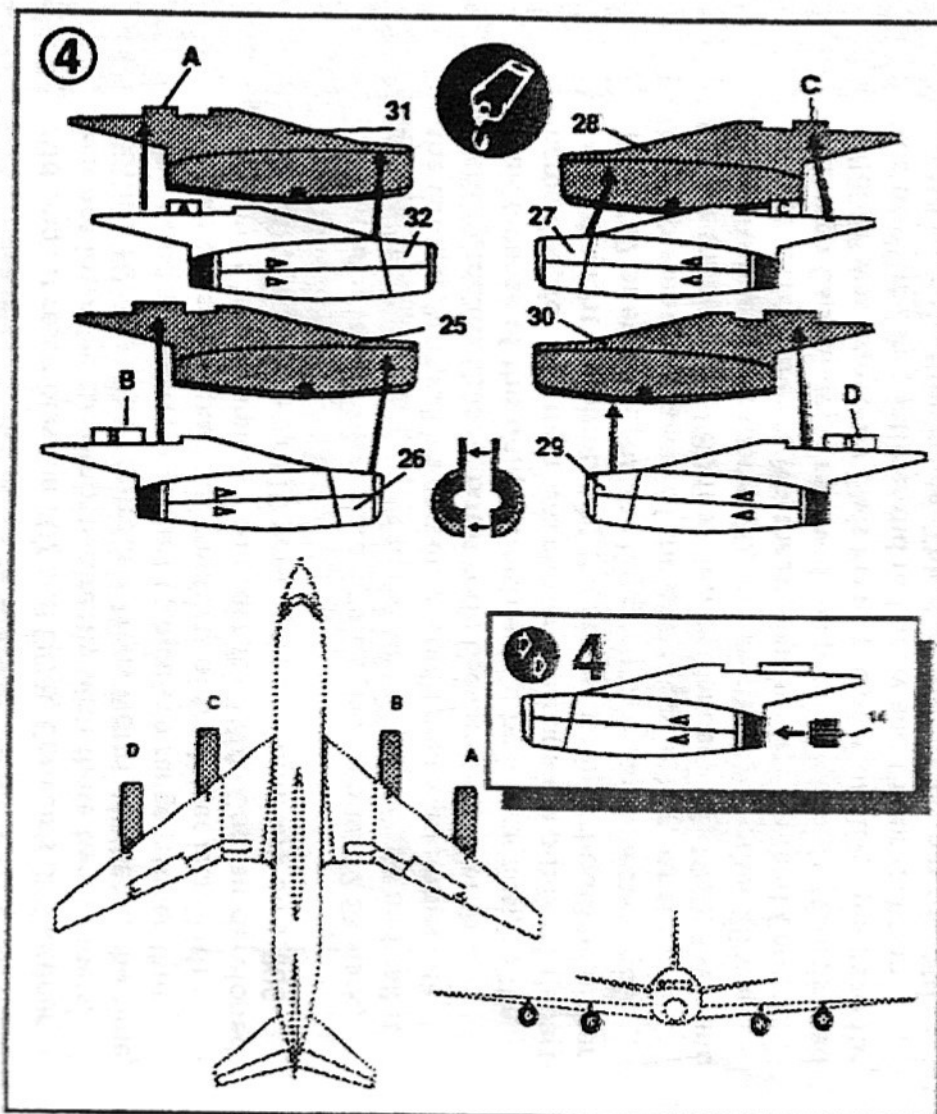
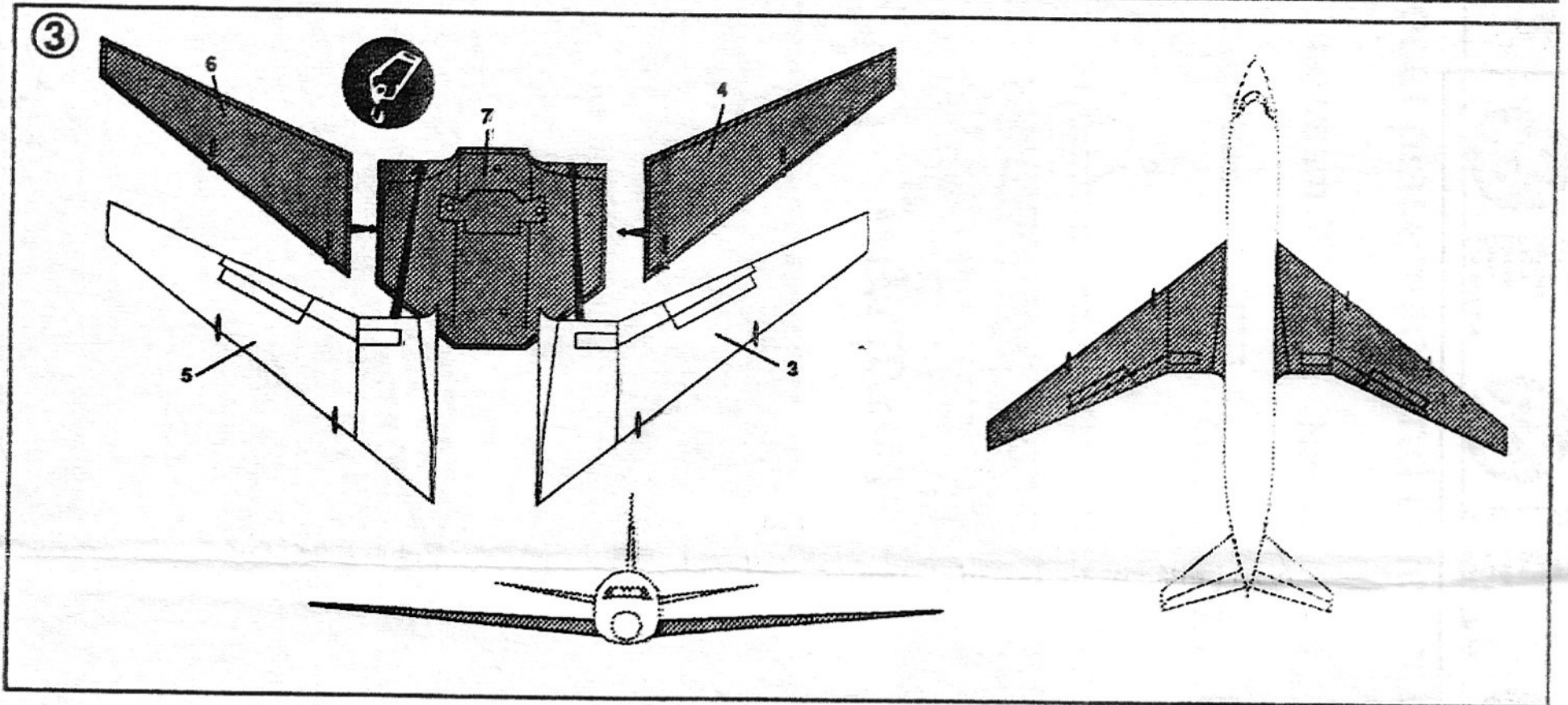
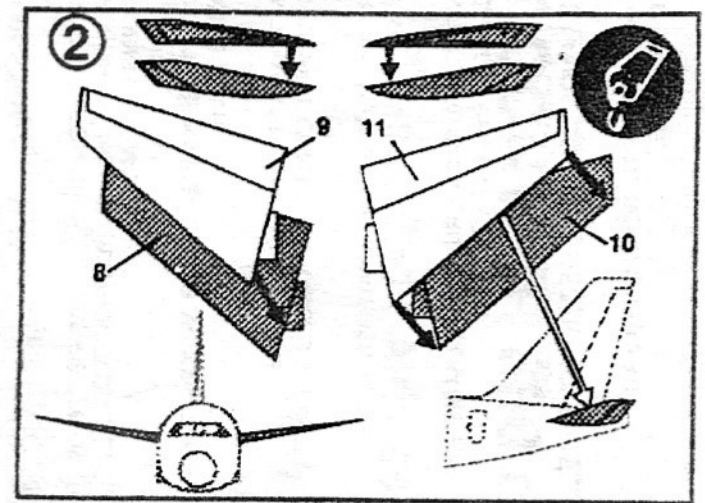
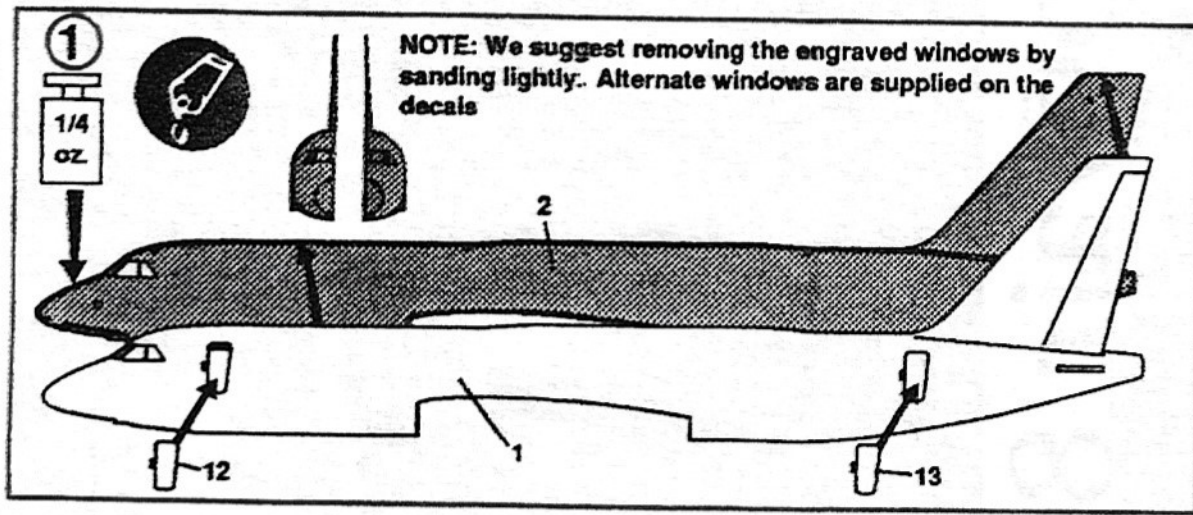

# CONVAIR 880 decal placement and color scheme

05502

Trans World Airlines Starstream 880



Natural Metal



Red (FS 11136)



Glossy White



Flat Black

2 4 6 10 11 on right side.

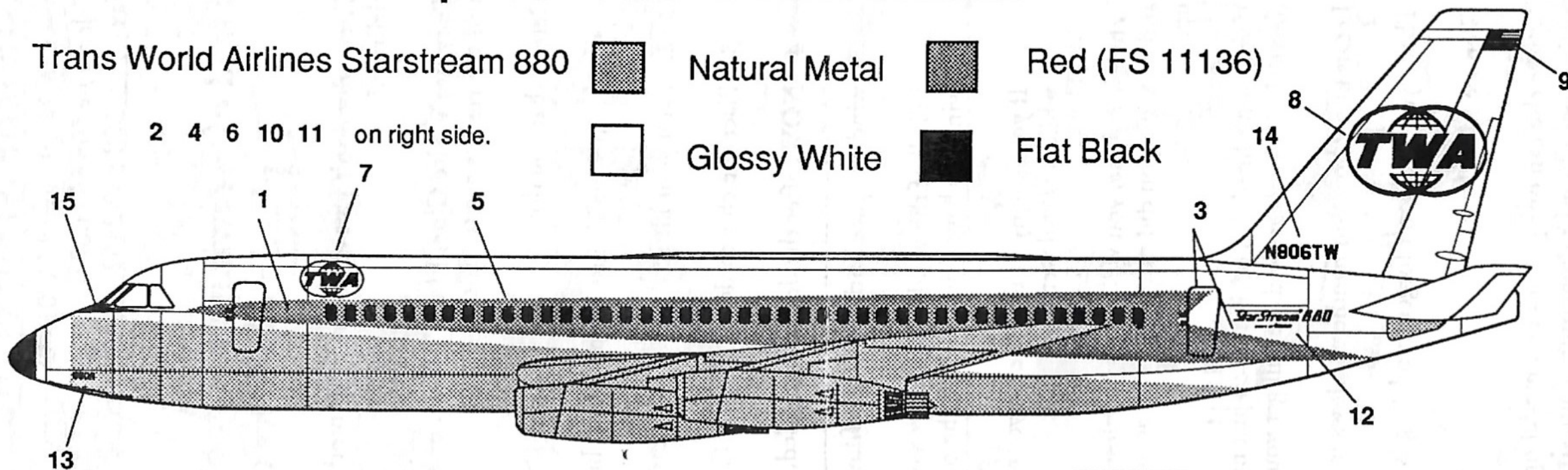

GLENCOE

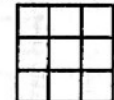

MODELS

SWISSAIR 880

20 21 22 25

on right side.

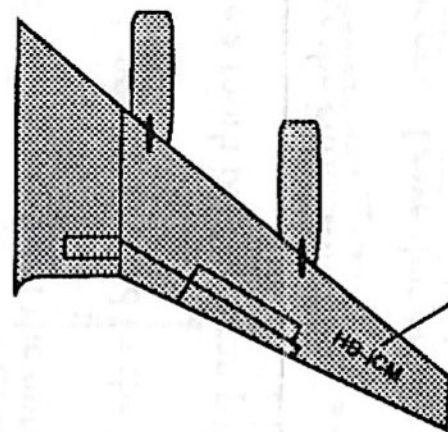

23 Upper right and lower left wings.

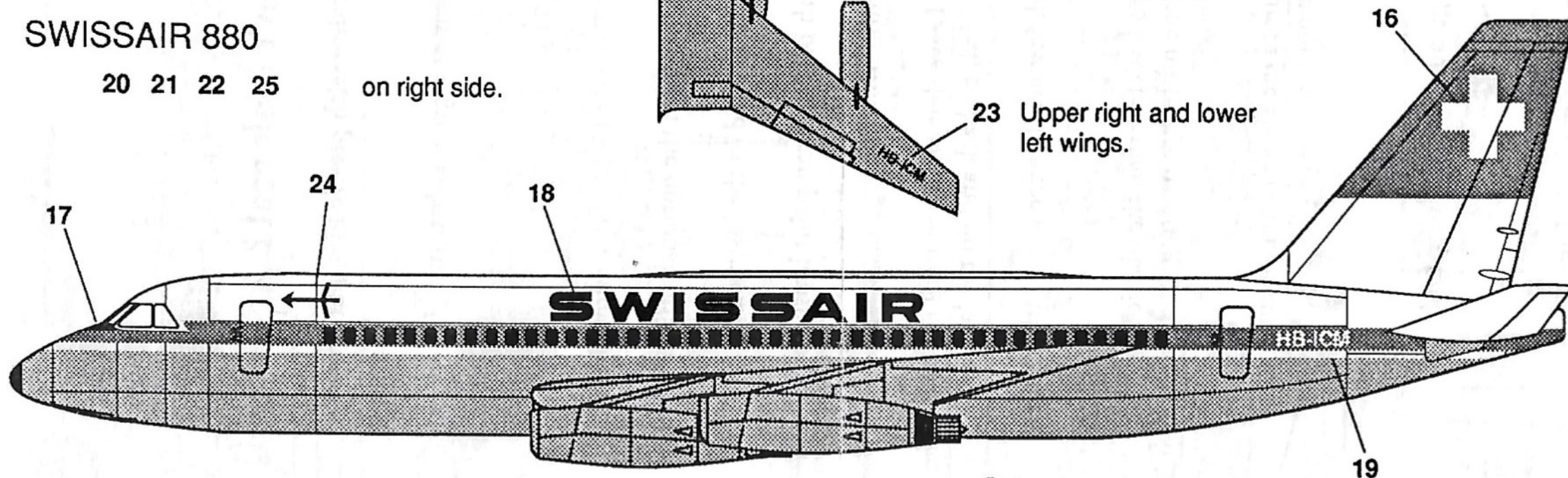

## **Glencoe Models Inc.**

Box 846. Northboro. MA 01532

Telephone 508.869.6877

Fax 508.869.2462

---

### **Tired of screwing up a good kit with those stupid little plastic windows that don't look real ?**

**Then why don't you try what most modelers are doing with plastic kits, particularly airliners?**

**They use White Glue, Elmer's Glue, or Krystal Clear as a great substitute. It's so easy and the results are terrific.**

Here's what you do:

1. Build your kit just as you would but **DO NOT** install the plastic windows in step 3.
2. Paint your kit in the desired colors that you chose from the optional airliner livery.
3. Place the chosen decals on your Convair 880 as directed in the instructions.
4. **NOW**, after the decals have dried, take a tooth pick or clean paint brush and place a bead or dab of white glue or *Krystal Clear* on the tip. Roll the bead around in the window space until it forms a film over the entire window.

Fill all of the window spaces except for one. Leave that one open until the rest of the windows have dried. When the others have dried, go back and do the last one.

If you get any of the glue on your kit or decal, just gently wipe it off with a tissue while it is still wet.

When it is done, you will have a seamless window, no less clear than the plastic alternative and one that you did not have to fill around, sand, tape off before painting, and then touch up.

If you don't liked this option, then just mail or Fax us at the above listing or email us at [Smaug1415@aol.com](mailto:Smaug1415@aol.com) and we will get you the plastic option.

Let us know how you handle windows in airliner.

Thank you and don't forget: modeling is FUN! So go out and have some fun!

Glencoe Models.

Where else can one get tips and modeling advice for airliner models? Easy, go to [airlinermodelling@Yahoogroups.com](mailto:airlinermodelling@Yahoogroups.com). It is a very active group of airliner modelers.

GLENCOE  
MODELS

SCALE-MASTER®  
DECALS  
Award Winning Art  
INVIS-A-CLEAR®  
1991 LLOYD S. JONES

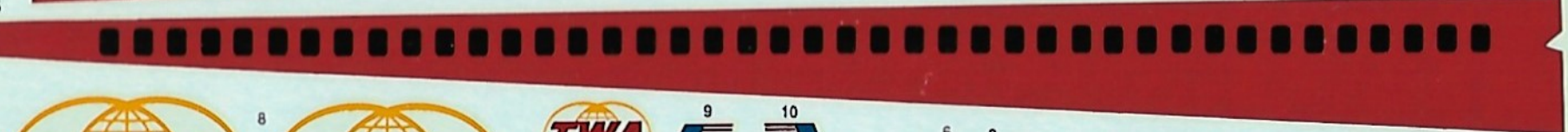
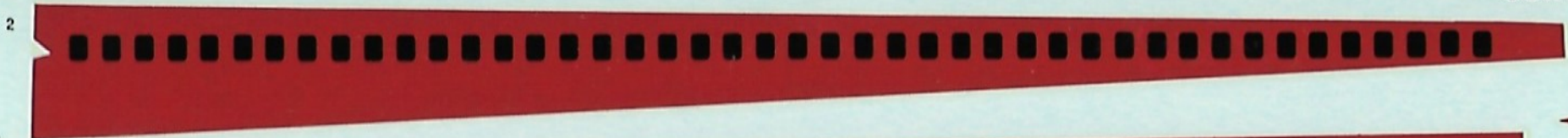

11 StarStream 880  
ONLY ON CONVAIR

13 8806 8806  
12 StarStream 880  
ONLY ON CONVAIR

14 N806TW  
N806TW

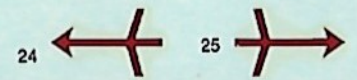
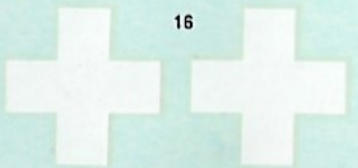

18 SWISSAIR

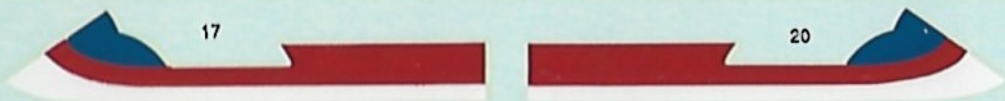
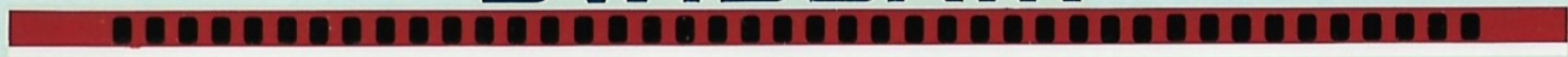

23 HB-ICM

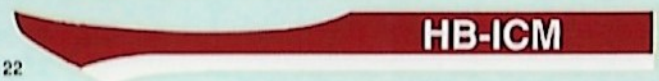

HB-ICM

SWISSAIR

