



# Revell®

# F-105 D Thunderchief

4023-3800



REPUBLIC'S HUGE F-105 THUNDERCHIEF WAS THE FIRST AIR FORCE JET SPECIFICALLY DESIGNED FOR THE DUAL ROLE OF FIGHTER-BOMBER. LITERALLY HALF FIGHTER, HALF BOMBER, THE F-105 CARRIED A NOSE-MOUNTED ROTARY CANNON AND MISSILES FOR DOGFIGHTING. BUT THE SPACIOUS FUSELAGE ALSO HELD A BOMB-BAY ABLE TO CONTAIN A NUCLEAR WEAPON.

DURING THE VIETNAM WAR, F-105S OPERATED IN THEIR DUAL CAPACITY, CARRYING UP TO 12,000 LBS OF BOMBS UNDER THEIR WINGS, WHILE THE WEAPON BAY CARRIED A SPARE FUEL TANK TO EXTEND THEIR RANGE. THOUGH MOST OF THE F-105'S

MISSIONS WERE BOMBING RAIDS, THE BIG PLANES DESTROYED NEARLY THIRTY RUSSIAN-BUILT MIG FIGHTERS USED BY THE NORTH VIETNAMESE.

THE THUNDERCHIEF WAS A STURDY MACHINE AND ONE EVEN RETURNED SAFELY TO ITS BASE WITH A WHOLE SAM MISSILE BURIED IN THE SIDE OF ITS FUSELAGE. OTHERS CAME HOME WITH LARGE PORTIONS OF THE AIRFRAME MISSING ENTIRELY.

FOLLOWING THE WAR, THE THUNDERCHIEF WAS ASSIGNED TO AIR NATIONAL GUARD UNITS IN THE STATES, AND WAS FINALLY RETIRED FROM SERVICE IN 1983.

**ENGLISH:** ASSEMBLY DRAWINGS SHOULD BE REVIEWED BEFORE PROCEEDING WITH CONSTRUCTION. A NUMBER IDENTIFIES EACH PLASTIC PART FOR YOUR CONVENIENCE. PAINT SMALL PARTS ON RUNNER BEFORE REMOVING. ALLOW PAINT TO DRY THOROUGHLY BEFORE CONTINUING ASSEMBLY OF KIT. SCRAPE CHROME OR PAINT AT AREA TO BE GLUED. WASH PLASTIC IN MILD DETERGENT SOLUTION. RINSE AND LET DRY FOR BETTER PAINT AND DECAL ADHESION.

**FRAÇAIS:** ÉTUDIEZ LES SCHEMAS DE MONTAGE AVANT DE COMMENCER LA CONSTRUCTION. UN NUMERO IDENTIFIE CHAQUE PIECE EN PLASTIQUE POUR PLUS DE FACILITE. PEIGNEZ LES PETITES PIECES SUR LE COUREUR AVANT DE LES ENLEVER. LAISSEZ SECHER LA PEINTURE AVANT DE CONTINUER LE MONTAGE DU KIT. GRATTEZ LE CHROME OU LA PEINTURE DANS LES ZONES QUI DOI-

VENT ÉTRE COLLEES. PUIS, LAVEZ LE PLASTIQUE DANS UNE SOLUTION FAIBLE DE DÉTERGENT, RINCEZ ET LAISSEZ SECHER À L'AIR POUR ASSURER UNE MEILLEURE ADHÉRENCE DE LA PEINTURE ET DES DÉCALCOMANIES.

**ESPAÑOL:** ESTUDIE LOS PLANOS DE MONTAJE ANTES DE INICIAR LA CONSTRUCCION. PARA FACILITAR LAS COSAS, CADA PIEZA DE PLASTICO LLEVA UN NUMERO DE IDENTIFICACION. PINTE LAS PIECITAS DEL CORREDOR ANTES DE QUITARLAS. PERMITA QUE LA PINTURA SE SEQUE BIEN ANTES DE PROSEGUIR EL MONTAJE DEL EQUIPO. RASPE EL CROMO O LA PINTURA DE LAS ZONAS QUE SE VAYAN A ENCOLAR. LAVE EL PLASTICO EN UNA SOLUCION LIGERA DE DETERGENTE, ENJUAGUELO Y DEJALO SECAR AL AIRE PARA OBTENER UNA MEJOR ADHERENCIA DE LA PINTURA Y LAS CALCOMANIAS.



GLUE  
COLLE  
COLA



NO GLUE REQUIRED  
PAS BESOIN DE COLLE  
NO SE REQUIERE COLA



DO IT THIS MANY TIMES  
LE FAIRE CE NOMBRE DE FOIS  
HAGALO TODAS ESTAS VECES



OPTIONAL  
OPTIONNEL  
OPCIONAL

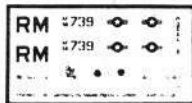

APPLY DECALS  
COLLEZ LES DÉCALCOMANIES  
PEGUE LAS CALCOMANIAS



SHOWN ASSEMBLED  
PRESENTE ASSEMBLE  
SE PRESENTA MONTADO



CLEAR  
TRANSPARENT  
TRANSPARENTE



GREEN  
VERT  
VERDE

|          |             |            |               |
|----------|-------------|------------|---------------|
| <b>A</b> | OLIVE GREEN | VERT OLIVE | VERDE OLIVA   |
| <b>B</b> | DARK GREEN  | VERT FONCE | VERDE OSCURO  |
| <b>C</b> | WOOD TAN    | BRUN BOIS  | MORENO MADERA |
| <b>D</b> | LIGHT GRAY  | GRIS CLAIR | GRIS CLARO    |

|          |               |                |               |
|----------|---------------|----------------|---------------|
| <b>E</b> | MATT BLACK    | NOIR MAT       | NEGRO MATE    |
| <b>F</b> | METALLIC GRAY | GRIS METALLISE | GRIS METALICO |
| <b>G</b> | MATT YELLOW   | JAUNE MAT      | AMARILLO MATE |

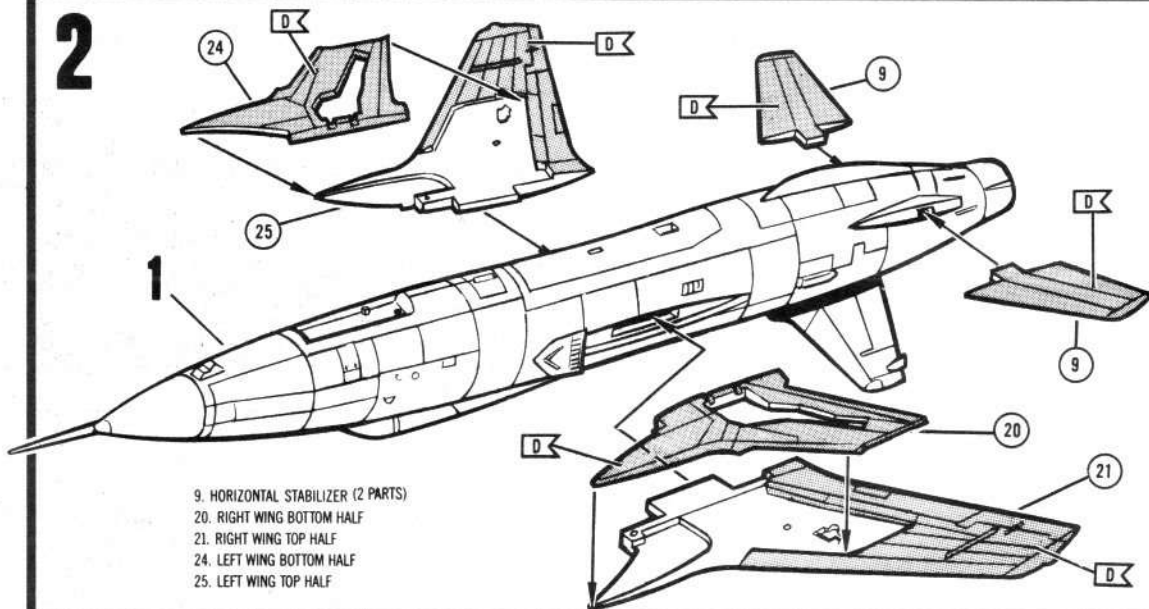
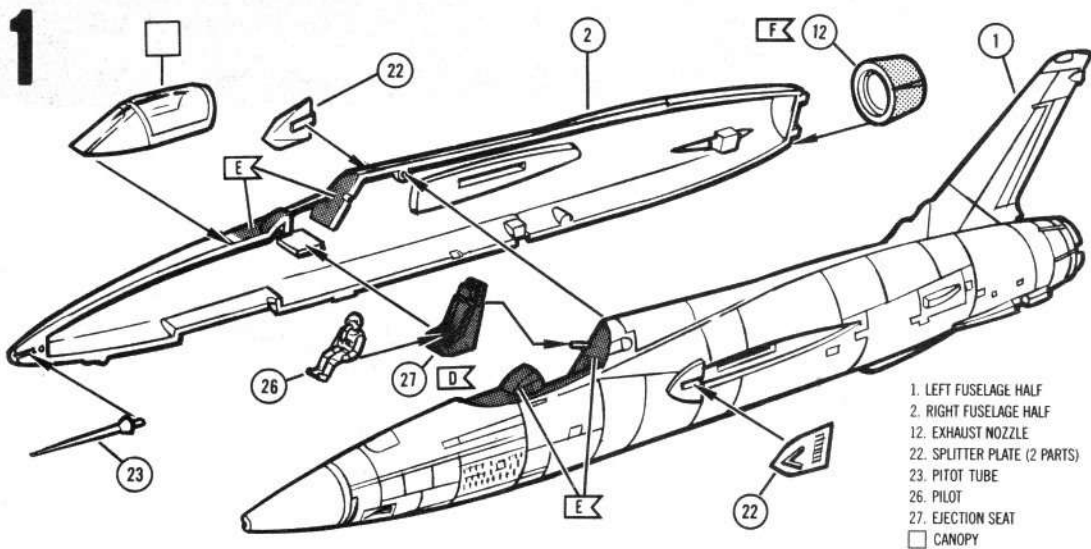

# 3 (?)

5. MAIN LANDING GEAR DOOR CLOSED — RIGHT SIDE  
6. MAIN LANDING GEAR DOOR CLOSED — LEFT SIDE  
11. NOSE WHEEL GEAR DOOR GEAR UP

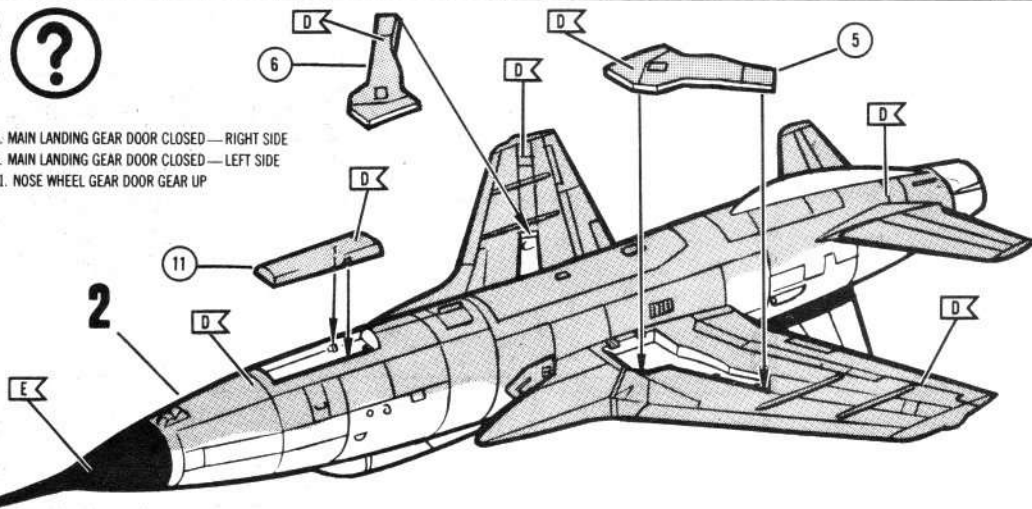

**4**

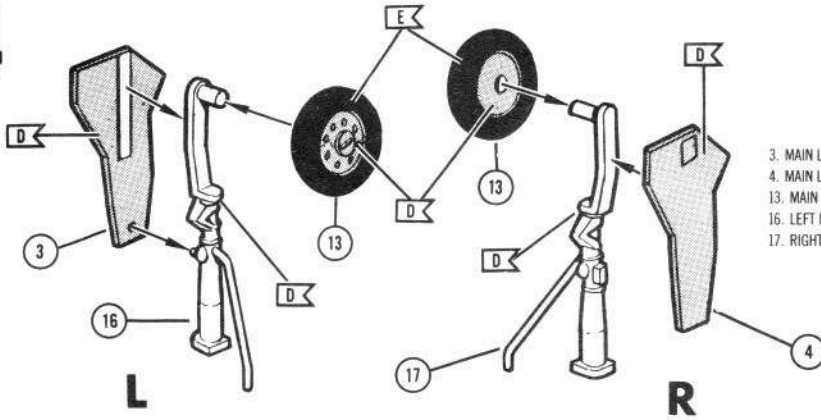

- 3. MAIN LANDING GEAR STRUT DOOR—LEFT SIDE
- 4. MAIN LANDING GEAR STRUT DOOR—RIGHT SIDE
- 13. MAIN LANDING GEAR WHEELS (2 PARTS)
- 16. LEFT MAIN LANDING GEAR
- 17. RIGHT MAIN LANDING GEAR

**5** (?)

- 7. OUTBOARD MAIN LANDING GEAR DOOR—LEFT SIDE
- 8. OUTBOARD MAIN LANDING GEAR DOOR—RIGHT SIDE
- 10. NOSEWHEEL LANDING GEAR
- 14. NOSEWHEEL DOOR—RIGHT SIDE
- 15. NOSEWHEEL DOOR—LEFT SIDE
- 18. INBOARD MAIN LANDING GEAR DOOR—RIGHT SIDE
- 19. INBOARD MAIN LANDING GEAR DOOR—LEFT SIDE

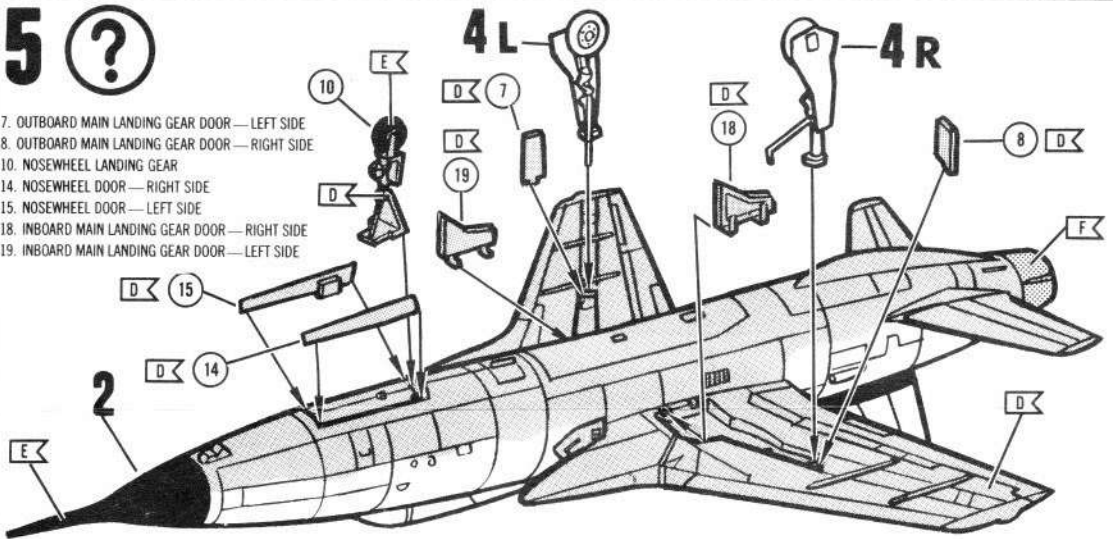

**6**

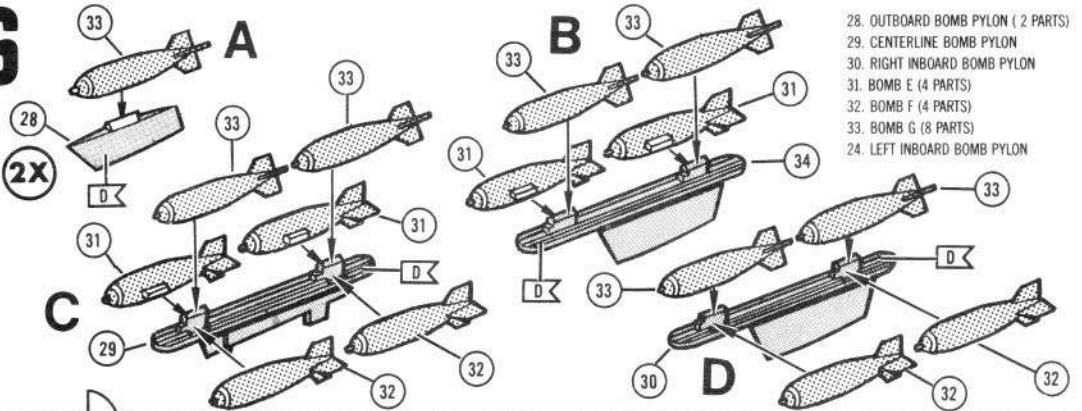

- 28. OUTBOARD BOMB PYLON ( 2 PARTS)
- 29. CENTERLINE BOMB PYLON
- 30. RIGHT INBOARD BOMB PYLON
- 31. BOMB E ( 4 PARTS)
- 32. BOMB F ( 4 PARTS)
- 33. BOMB G ( 8 PARTS)
- 24. LEFT INBOARD BOMB PYLON

**7**

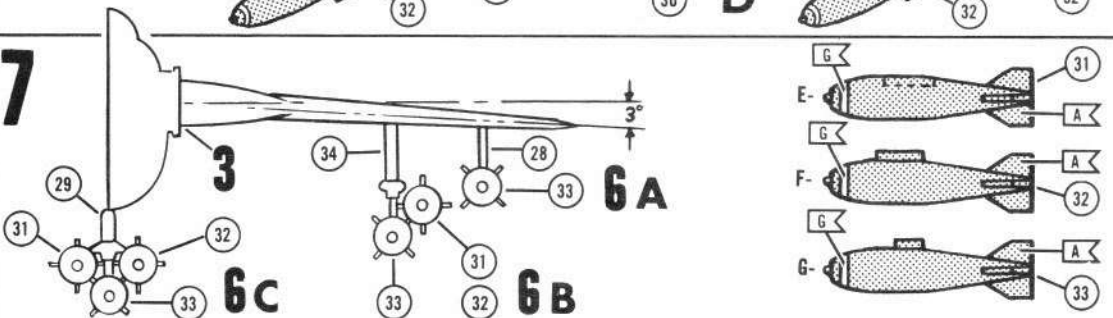

- 31
- 32
- 33
- 34
- 28
- 29
- 30
- 31
- 32
- 33

8

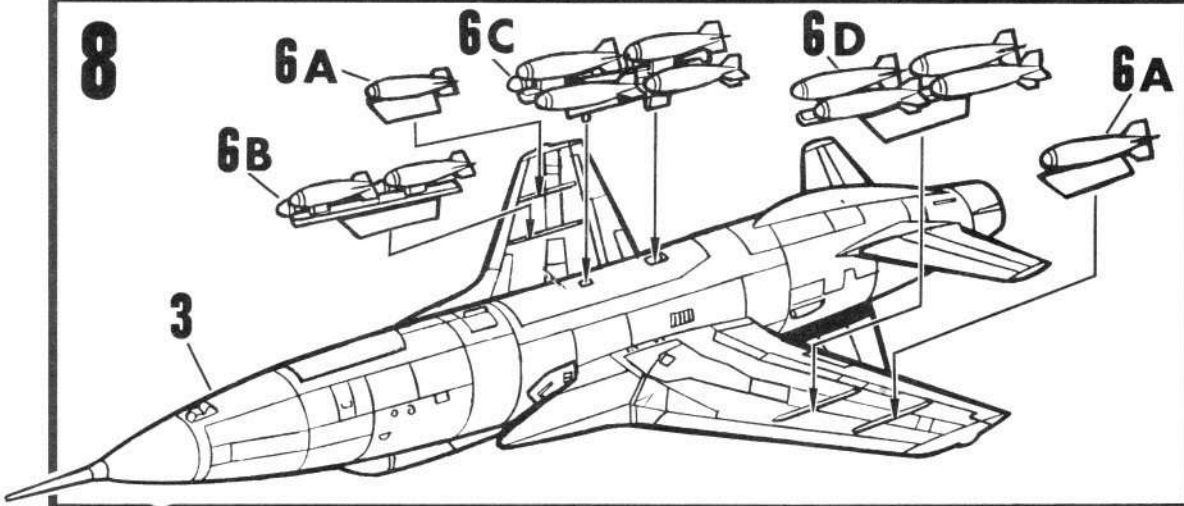

9

|    |     |   |   |
|----|-----|---|---|
| RM | 739 | ◆ | ◆ |
| RM | 739 | ◆ | ◆ |



OLIVE GREEN  
VERT OLIVE  
VERDE OLIVA



LIGHT GRAY  
GRIS CLAIR  
GRIS CLARO

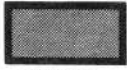

DARK GREEN  
VERT FONCE  
VERDE OSCURO



WOOD TAN  
BRUN BOIS  
MORENO MADERA



METALLIC GRAY  
GRIS METALLISE  
GRIS METALICO



MATT BLACK  
NOIR MAT  
NEGRO MATE

