

Heinkel He P.1078B



1:72
PLT 169

Pod označením Heinkel P.1078 byly připravovány tři různé projekty stíhaček označené písmeny A, B a C. Všechny měl pohánět motor HeS 011. Konstrukční práce probíhaly na začátku roku 1945, konec války je ukončil. Heinkel P.1078 byl projektován jako bezocasý, s motorem mezi dvěma trupovými gondolami. V levém trupu byla kabina pilota, v pravém výzbroj a radar. Podvozek byl předový. Rozpětí: 9,43m, délka: 6,04m, max. rychlost 1025 km/h, výzbroj: 2x kanón MG 108 ráže 30 mm

There were three different projects of a Heinkel P.1078 fighter in preparation. They were all designated P.1078 and with letters A,B and C. All this aircraft should had been powered by HeS 011 engine. The construction had started in the beginning of 1945 and the end of the war stopped them. Heinkel P.1078 was designed as a aircraft without tailplanes, its engine situated between two fuselages. The pilot's cockpit was to be in the left fuselage, in the right one were planned the armament and radar. The undercarriage was of the nose type. Wing span - 9.43 m, Length - 6.04 m, Max. speed - 1025 Kph, Armament - 2x 30 mm, MG 108 cannons

PARTS

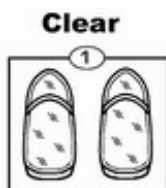
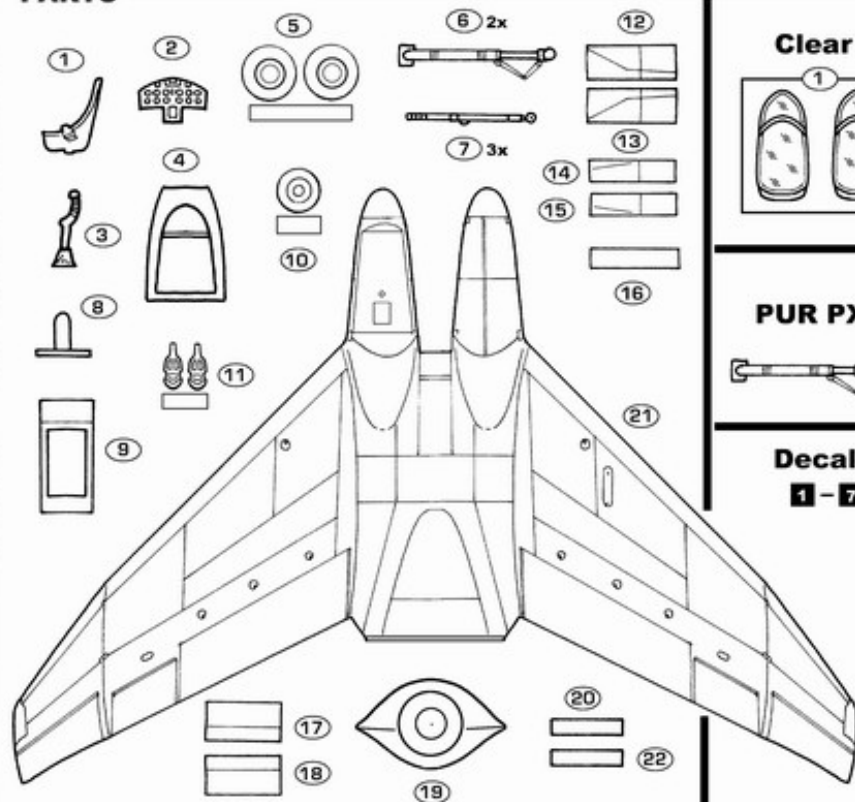

Decals

1 - 7

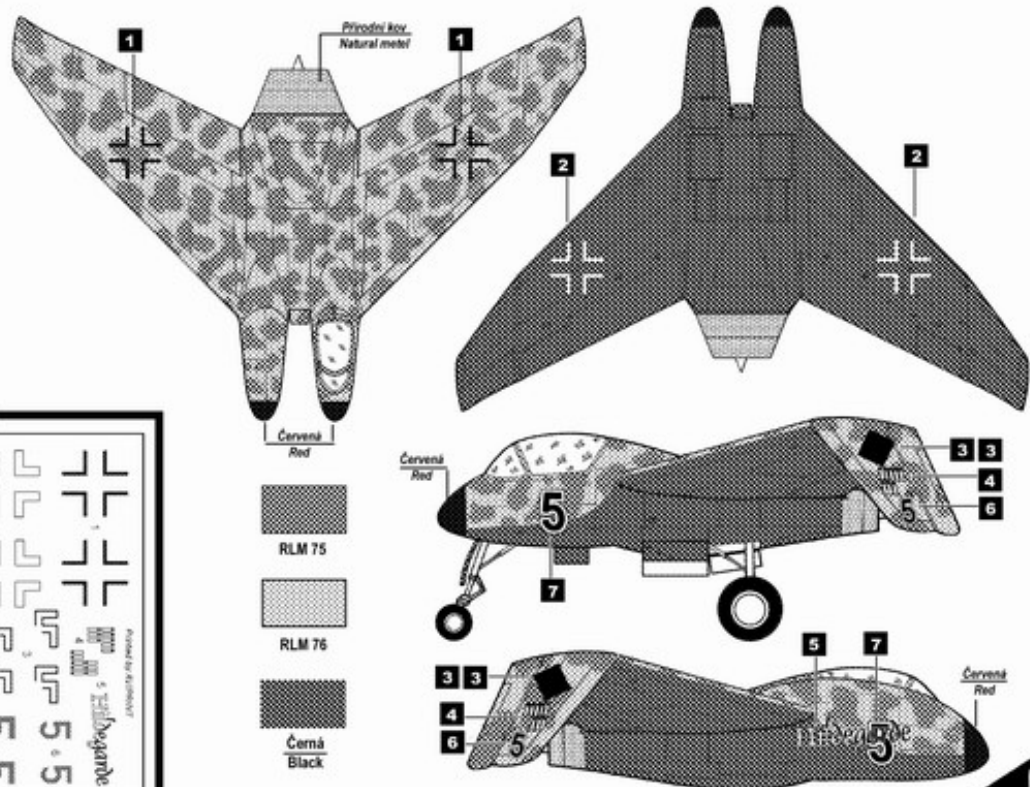
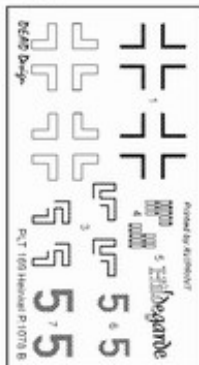

a

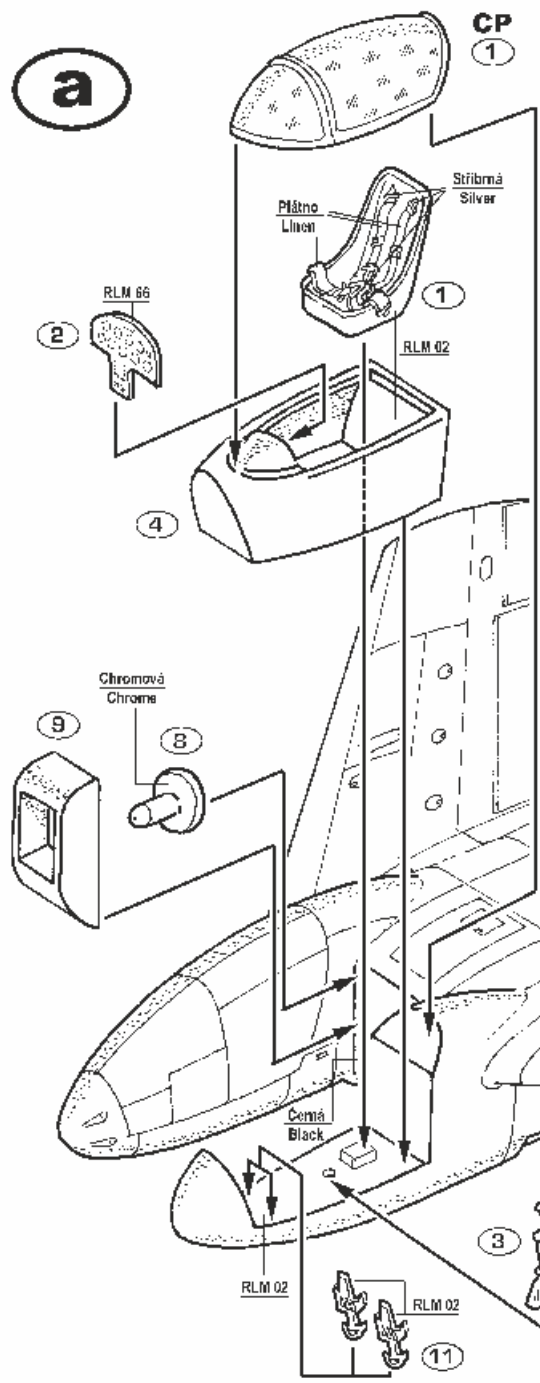

info

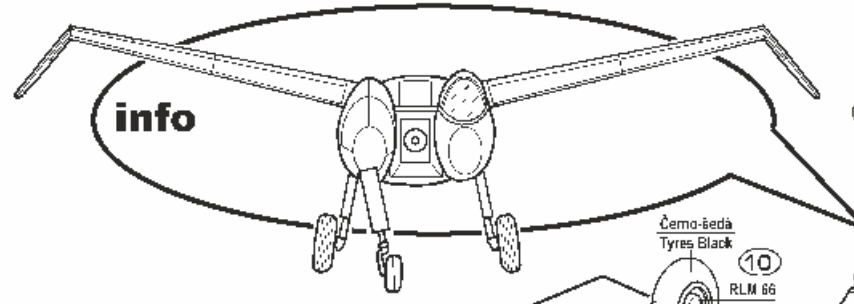

b

