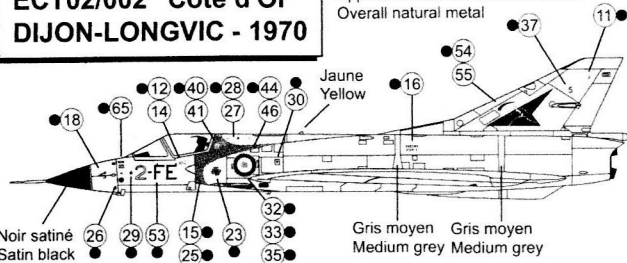

**ECT02/002 "Côte d'Or"
DIJON-LONGVIC - 1970**

BD 48-10

Appareil entièrement métal naturel
Overall natural metal

10-SJ:
Cet appareil fut accidenté en 1978 près de Grimsby en Angleterre sans perte humaine lors d'un échange avec le 5 Sqdn de la RAF. This a/c crash-landed near Grimsby during an exercise with Lightnings from 5 Sqdn. The pilot ejected successfully. The aircraft was repaired and flew again 2 years later.

● indique marquage des deux côtés.
- indicates marking on both sides

**EC01/010 "Valois"
CREIL - 1978**Trappes de train avant
Front u/c doors

10-SJ:

Décal (36) = 2-FE,
10-LE & 10-SE
2-LI = pas de lettre /
no letter

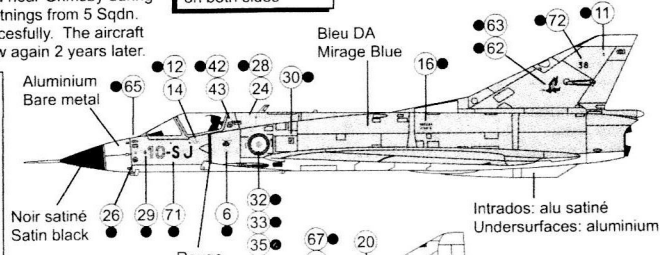
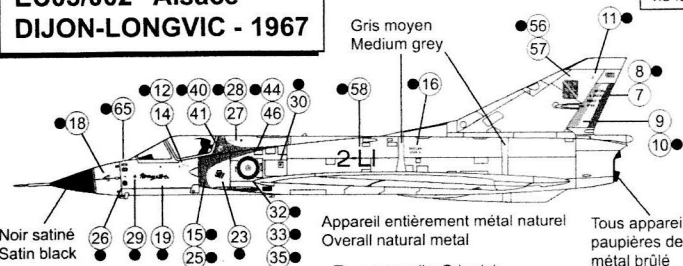
**EC03/002 "Alsace"
DIJON-LONGVIC - 1967**Gris moyen
Medium grey

10-LE:
Intrados gauche
Port lower surfaces

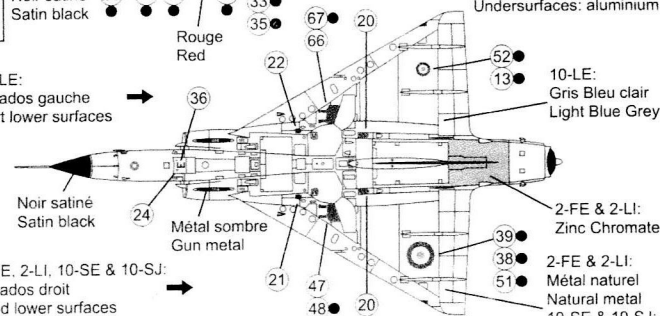
**EC03/010 "Vexin"
DJIBOUTI - 1978**

Tous appareils: Gris clair,
bords d'attaque noir mat
All a/c: Light Grey with matt
black leading edges

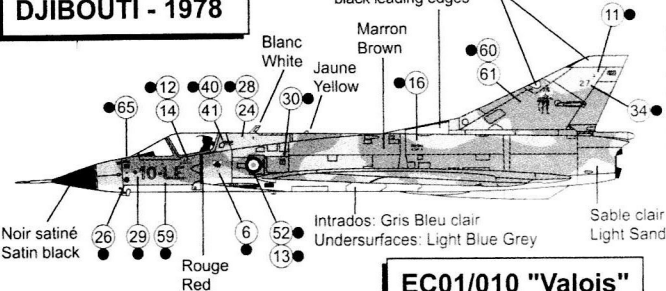

10-LE: vue de l'extrados.
Les couleurs de camouflage
"Outre-Mer" fanéaient rapide-
ment sous le soleil africain
donnant aux appareils des
aspects très différents. On
note aussi de nombreuses
traces de salissures sur
la couleur "sable" plus
particulièrement.

Tous appareils: Blanc
All a/c: White panel

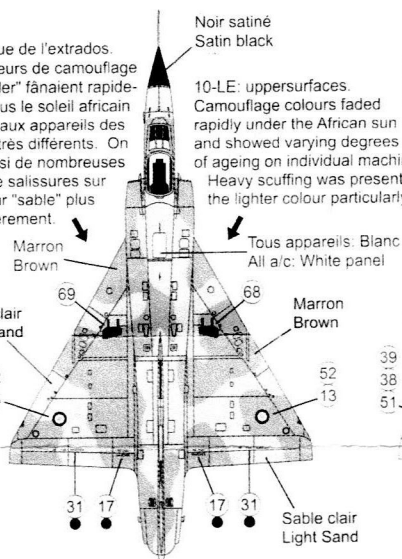
Sable clair
Light Sand

2-FE & 2-LI:
Extrados gauche
Upper port side

10-SE & 10-SJ:
Extrados droit
Stbd upper surfaces

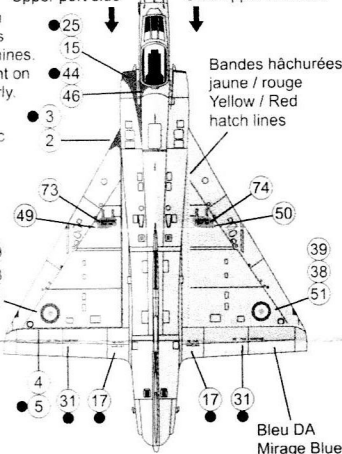
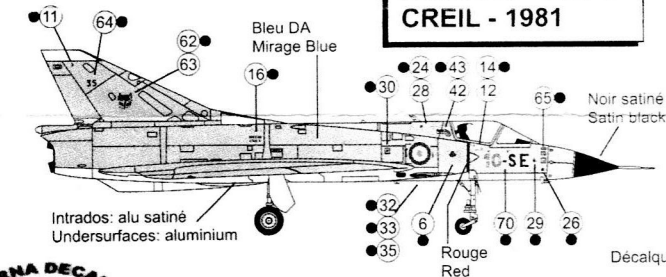
**EC01/010 "Valois"
CREIL - 1981**

Décalque / Transfer 1 = surplus

Bandes hâchurées rouges / Red hatched lines = surplus

Note : les cocardes et drapeaux de gouvernail ne sont pas présents sur cette planche.
Roundels and rudder flags are not included in this sheet.

BERNA DECALS

