

Úprava oken pro francouzskou transportní verzi (kamoufláž B) - vyrobte pro obě strany.
Conversion for French transport version (Camo B) - scratchbuilt both sides' windows.

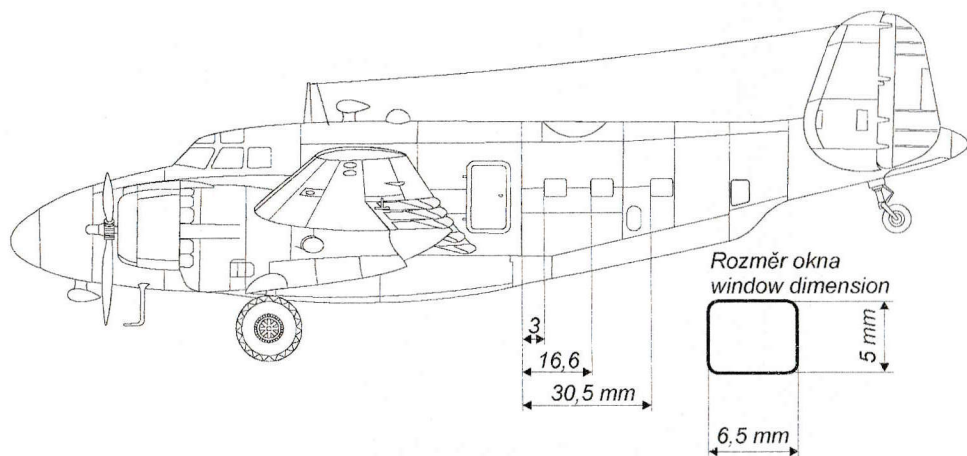

Rozměr okna
window dimension

1/72

MPM
Production

limited run plastic kits

High quality injected plastic kits - short run/ Vstříkované modely - limitovaná série

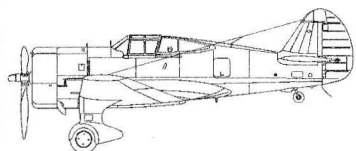

SH72051 Hawk H-75M/N/O

1/72

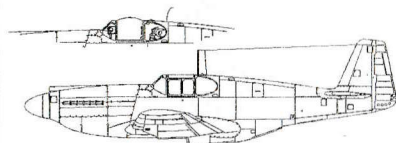

SH72043 P-51A/ F-6A Mustang

1/72

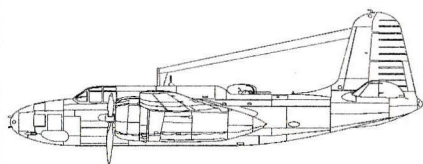

MPM72539 A-20G Havoc "South Pacific Warrior"

1/72

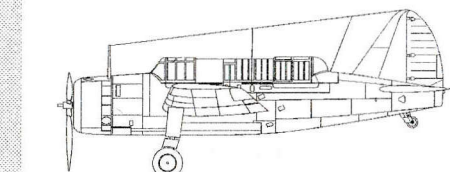

SH72179 SB2A-3 Bucanner

1/72



Bližší informace na internetových stránkách www.cmkkits.com
Further information at internet pages www.cmkkits.com

Special
HOBBY
1/72

SH 72213

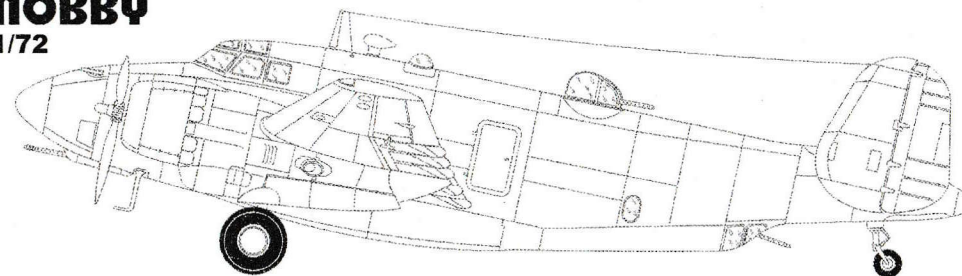

PV-2 Harpoon "Post War Service"

(CZ)

Ze svého původně civilního letounu Lockheed 18 Lodestar vyvinula společnost Lockheed dle britských požadavků vojenskou variantu Lockheed 37. Do Velké Británie byla dodávána v několika verzích jako Ventura Mk.I až GR Mk.V. Sloužila jak k denním náletům, tak k protiponorkovému hlídkování. US Navy a USAAF zařadilo tyto výkonné letouny do své výzbroje také. Podle verze motorů, výzbroje a dalšího vybavení se tyto letouny označovaly u USAAF B-34 a B-37, u US Navy a Marines dostaly označení PV-1 a PV-3. Při protiponorkovém hlídkování se tyto letouny velmi osvědčily. V oblasti Pacifiku sloužily i jako bitevní a noční stíhací letouny. Výkony byly tak vysoké, že mohly aktivně bojovat i s jednomotorovými japonskými stíhačkami.

V roce 1943 objednalo US Navy novou verzi. Mezi požadavky dominovala silnější výzbroj a delší dolet. Nový letoun PV-2 Harpoon vyšel z Ventury, dostal ale nové křídlo a zvětšené ocasní plochy. Proti PV-1 se zvětšil dolet, poněkud snížila maximální rychlost, ale vzrostla nosnost. První prototyp vzlétl v Burbanku v listopadu 1943. Objednávka na 500 ks byla zadána již v červnu 1943. Sériové letouny byly dodávány od března 1944. U prvních třiceti se objevily netěsnosti integračních křídelních nádrží. Po nápravě byly přesunuty k výcviku jako PV-2C. Další upravené stroje již dostávaly bojové jednotky. Kromě základní verze byla zahájena výroba verze PV-2D s upravenou příďí a mohutnější výzbrojí. S koncem války byly objednávky stornovány a tak vzniklo jen 35 kusů této verze. Harpoony byly vybaveny jednotky VPB-139 na Aleutách a VPB-142 na Tinianu. Později k nim přibýly jednotky VPB-144 a VPB-148 a VPB-153, které se ještě stihly zapojit do bojů proti Japonsku.

Po válce Harpoony vydržely u bojových jednotek do roku 1948. Od roku 1947 byly nahrazovány novým protiponorkovým a hlídkovým letounem Lockheed Neptune. Dále sloužily do padesátých let v záloze u Navy Reserve Wings.

V roce 1945 koupila Harpoony Brazílie, v rámci Programu spojenecké vojenské pomoci (Foreign Military Assistance Program) Harpoony obdržela letectva Portugalska, Itálie, Nizozemska, Francie, Jižní Afriky a Japonska. V Japonsku sloužilo i několik PV-2D. Několik Harpoonů léta dodnes.

Rozpětí: 22,87 m, délka: 15,88 m, max. rychlost: 453 km/h, dostup: 7 280 m, dolet s 900 kg pum: 2 832 km, dolet maximální: 4714 km

(GB)

According to the British military specification Lockheed company developed Lockheed 37 from its civilian Lockheed 18 Lodestar. It was delivered to Great Britain in several variants, starting as Ventura Mk.I to GR Mk.V. It served both as a day bomber and anti-submarine patrol aircraft. These powerful aircraft were also adopted by both US Navy and USAAF. According to used engines, armament and other equipment USAAF designated the aircraft B-34 and B-37; US Navy designated them PV-1 and PV-3. Their effectiveness during anti-submarine patrols was very high. In Pacific theatre these aircraft also served in ground attack and night fighter roles. Their performances were so high that they could outfight single engined Japanese fighters.

In 1943 US Navy ordered new version calling for heavier armament and better range. The new aircraft designated PV-2 Harpoon was derived from Ventura but it got new wings and enlarged tail planes. Comparing to PV-1, Harpoon had better range, lower maximal speed but increased maximum load. The first prototype took off in November 1943 in Burbank. The production order for 500 aircraft was already placed in July 1943. The production aircraft had started to be delivered since March 1944. The first thirty aircraft suffered from integral wing fuel tanks leakage. Once repaired these aircraft were transferred to training units as PV-2C. Subsequent modified aircraft were delivered to combat units. Also the production of PV-2D version started. It featured modified nose and heavier armament. As the war drew near the end the orders were cancelled so only 35 machines were produced. Harpoons were assigned to VPB-139 located in Aleutian Islands and VPB-142 on Tinian. Later on Harpoons were assigned to VPB-144, VPB-148 and VPB-153. These units participated in fights against Japanese Empire.

Harpoons served in combat units until 1948 in post war period. From 1947 were started being replaced by new anti-submarine patrol aircraft Lockheed Neptune. They stayed in Navy Reserve Wings up to the fifties of the last century. In 1945 Harpoons were purchased by Brazil. According to the Foreign Military Assistance Program, Harpoons were delivered to Portugal, Italy, Holland, France, South Africa and Japan. Also several PV-2D served in JASDF. Few Harpoons are still flyable in present.

Wingspan: 22.87m, Length: 15.88m, Max. Speed: 453kph, Service Ceiling: 7280m, Range with 900kg bomb load: 2832km, Max. Range: 4714 km

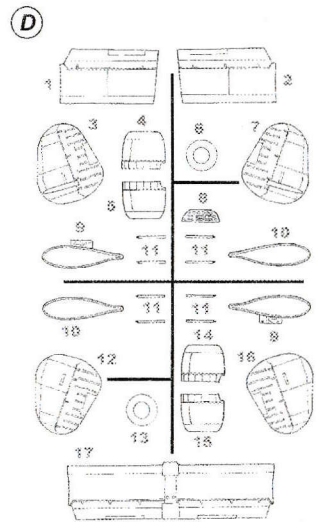
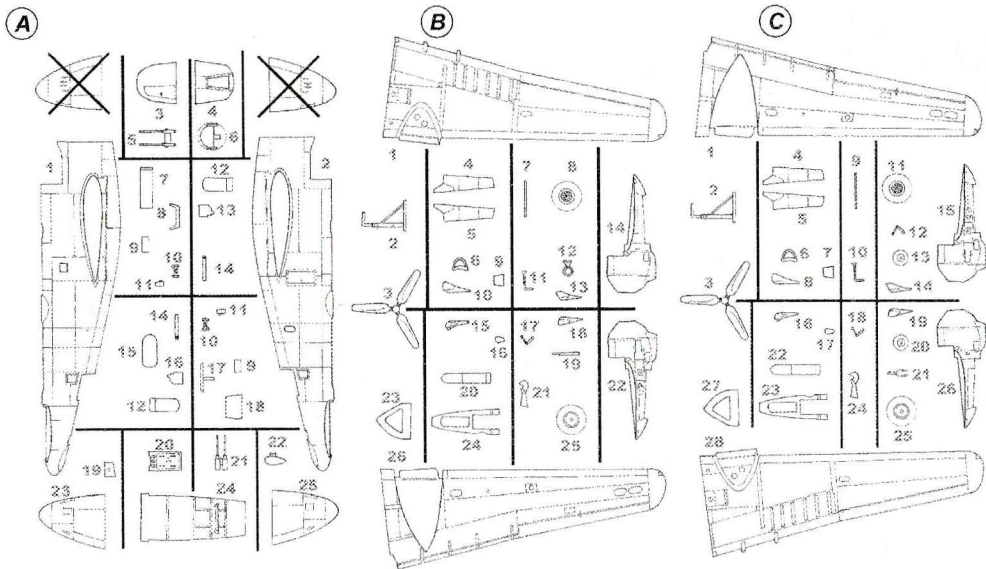

CLEAR PARTS (CP)

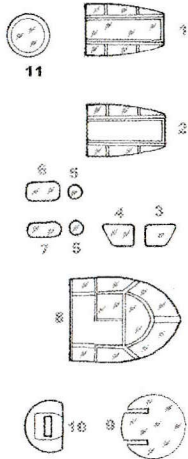

POLYURETHAN PARTS (PU)



Barvy GUNZE/ GUNZE Colour No.	
A	lesklá bílá/ Gloss White H1/C1
B	Černá/ BLACK H12/C33
C	Rezává/ Rust H33/C81
D	Lesklá mořská modrá/ Glossy Sea Blue H365/C365
E	Černá Pneu./ TIRE BLACK H77/C137
F	Tmavý kov/ Dark Iron MC214
G	Hliník/ ALUMINIUM H8/C8
H	Tmavá raččí šed/ Dark Gull Grey H317/C317
I	Interiér. zelená/ INTERIOR GREEN H58/C27
J	Chromová/ Chrome MC211
K	Ocelové šedá/ Steel Grey H75/C25
L	Žlutá/ Yellow H4/C4

1

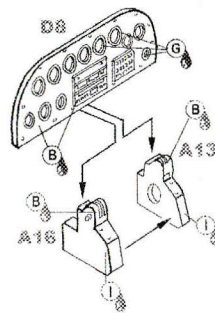

2

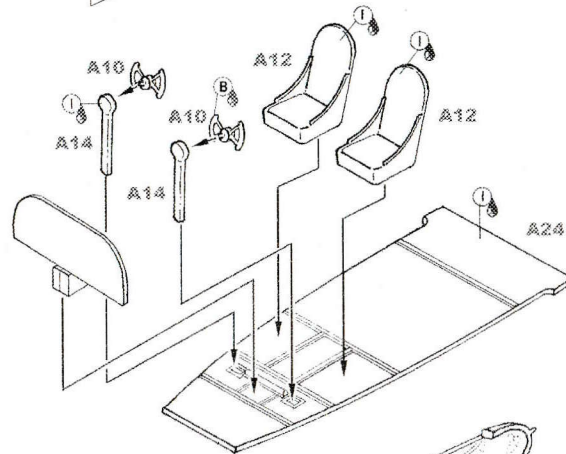

3

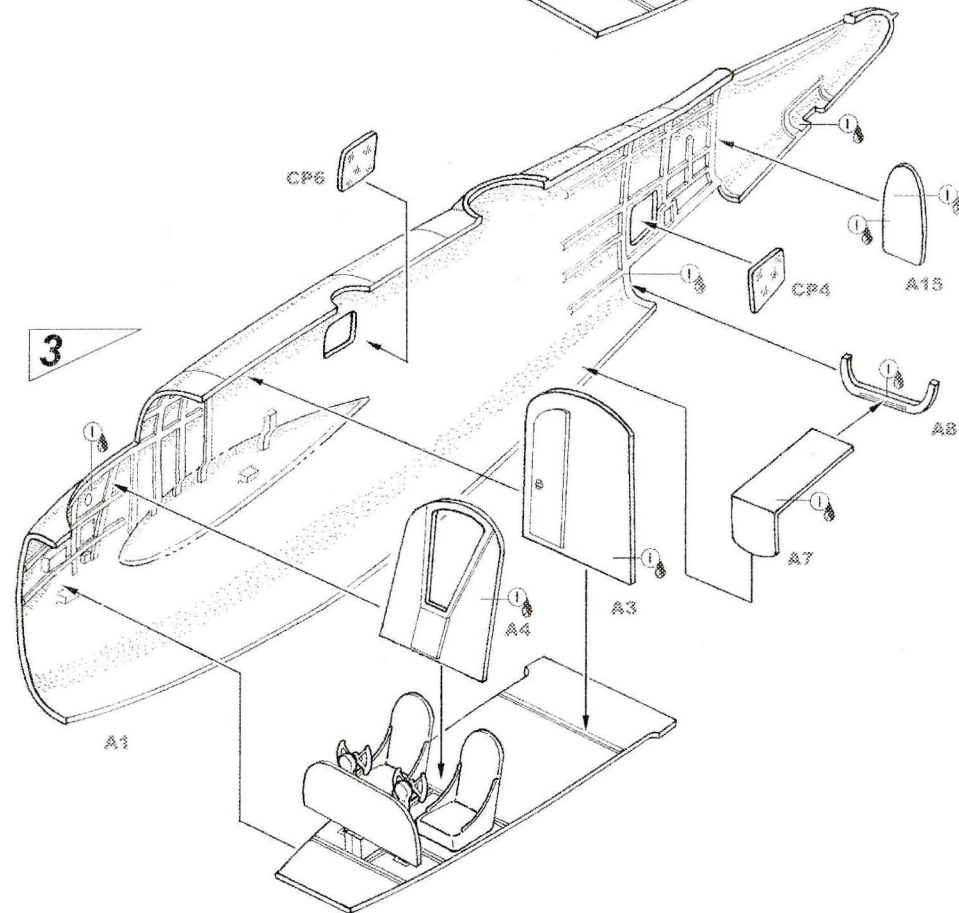

SYMBOLS

- MOŽNOST VOLBY / OPTIONAL NACH BELIEBEN / OPTION
- POUŽÍT KYANOAKRYLÁTOVÉ LEPIDLO / INSTANT CYANOACRYLATE GLUE / ZYANOAKRYLATKLEBER / ADHESIF CYANOACRYLAT
- OHNOUT BEND / BIEGEN / COURBER
- ZHOTOVIT NOVĚ / SCRATCH BUILD / FERTIGSTELLEN / ACHEVER
- ŘEZAT/VRTAT / CUT OFF/DRILL / ENTERNEN / DETACHER
- GSI colours code
- NÁTRIT / COLOUR / FARBEN / PEINDRE

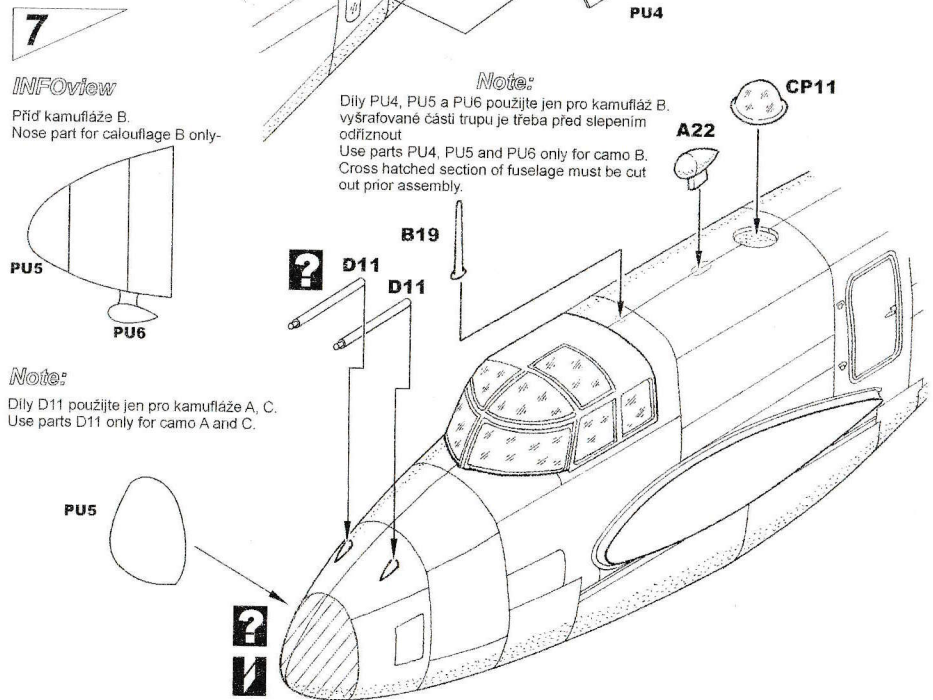
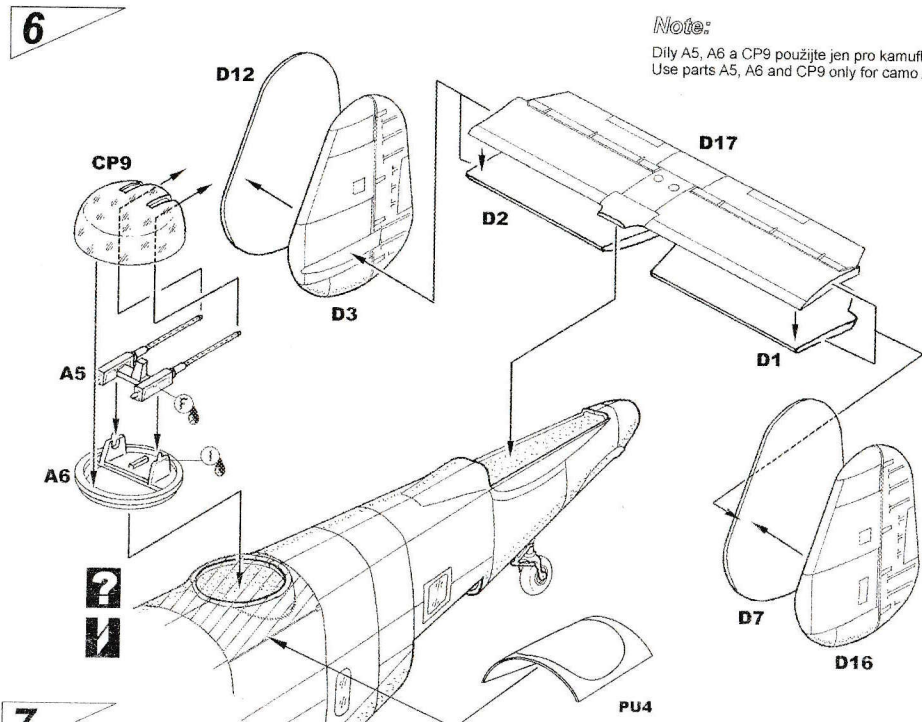
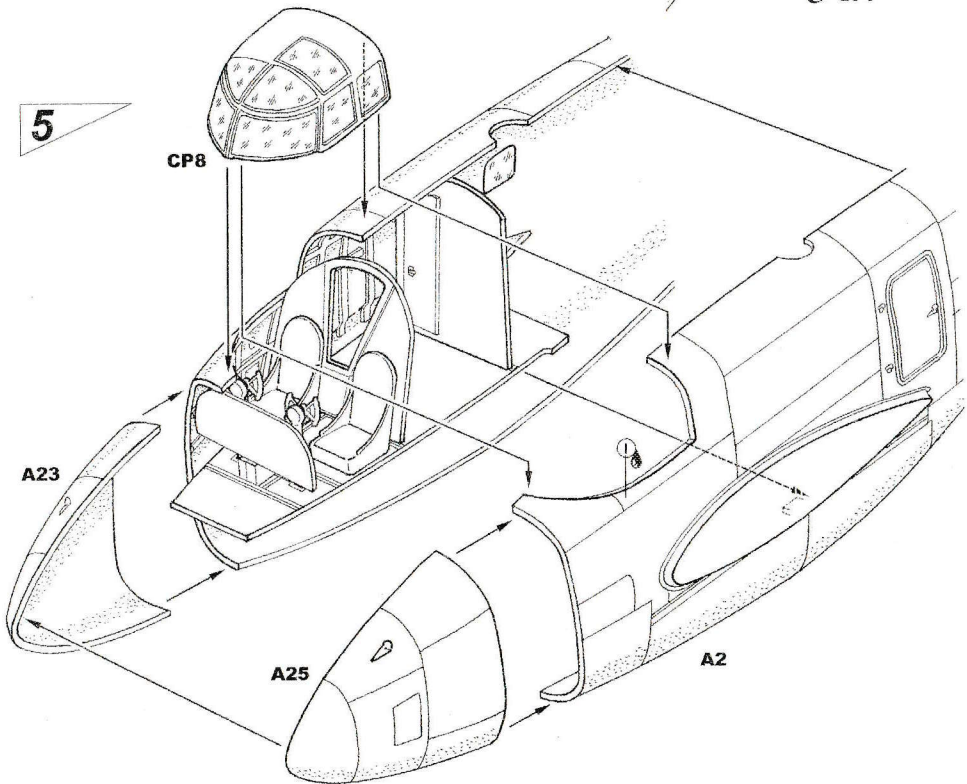
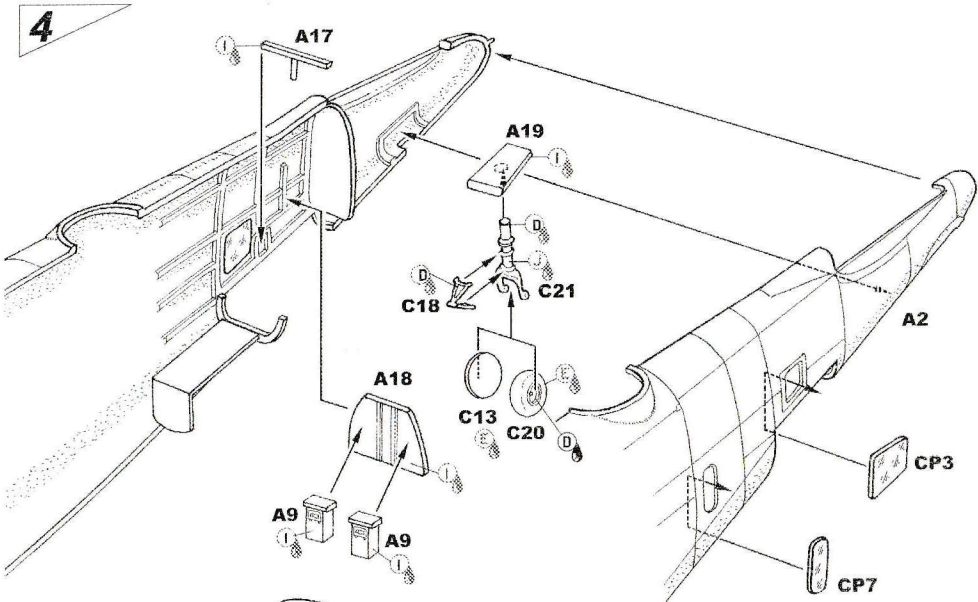

8

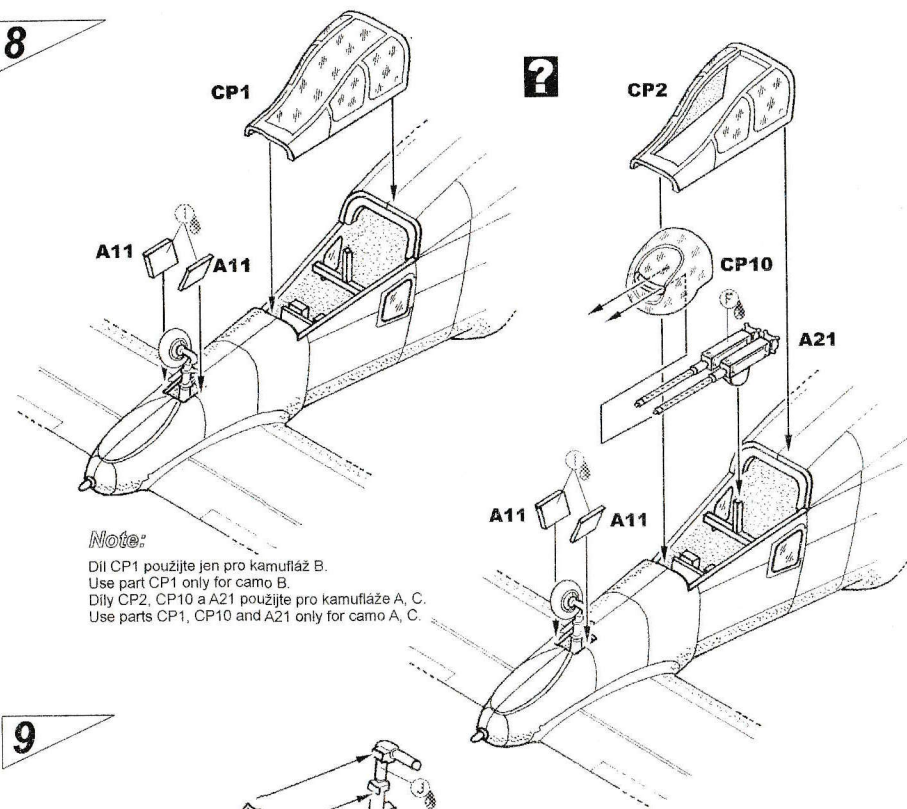

9

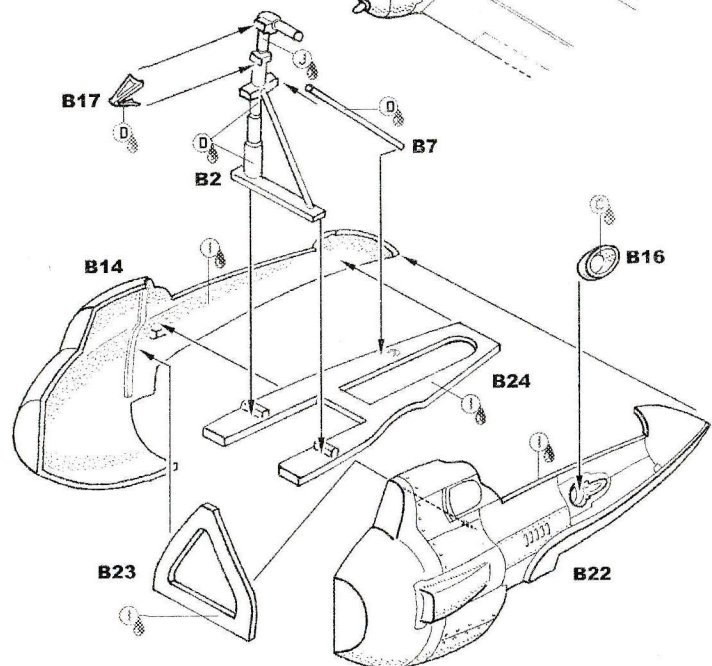

10

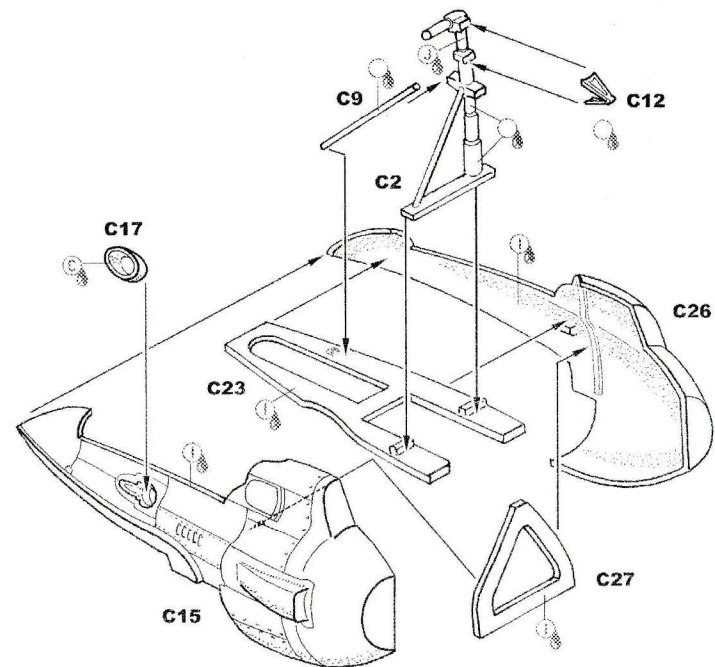

11

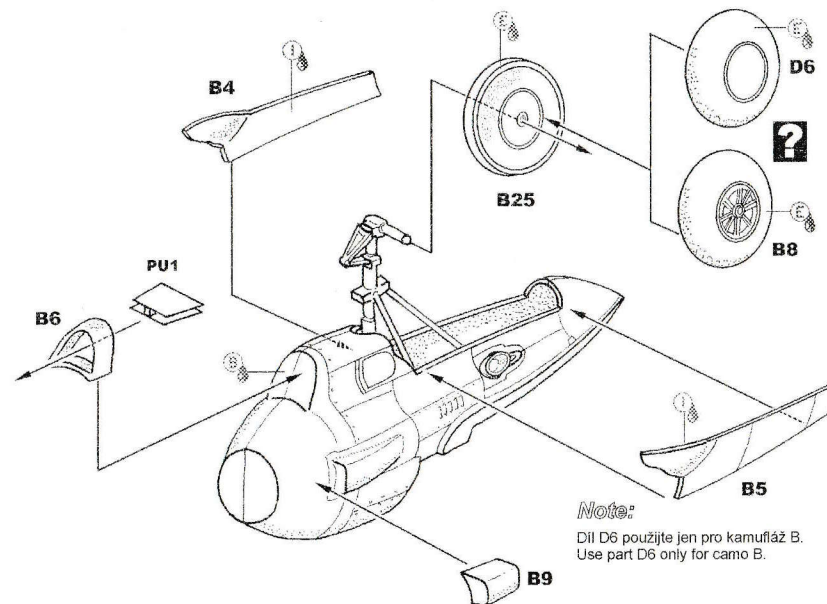

12

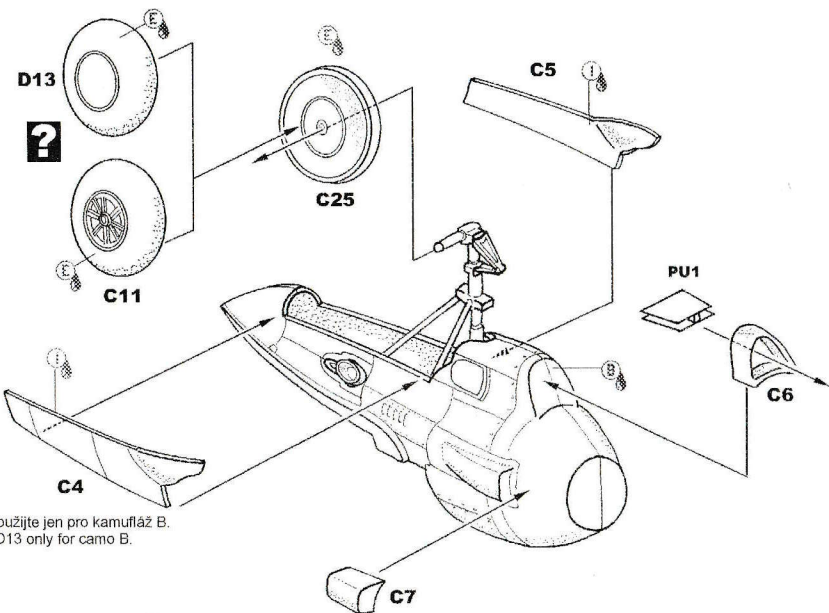

13

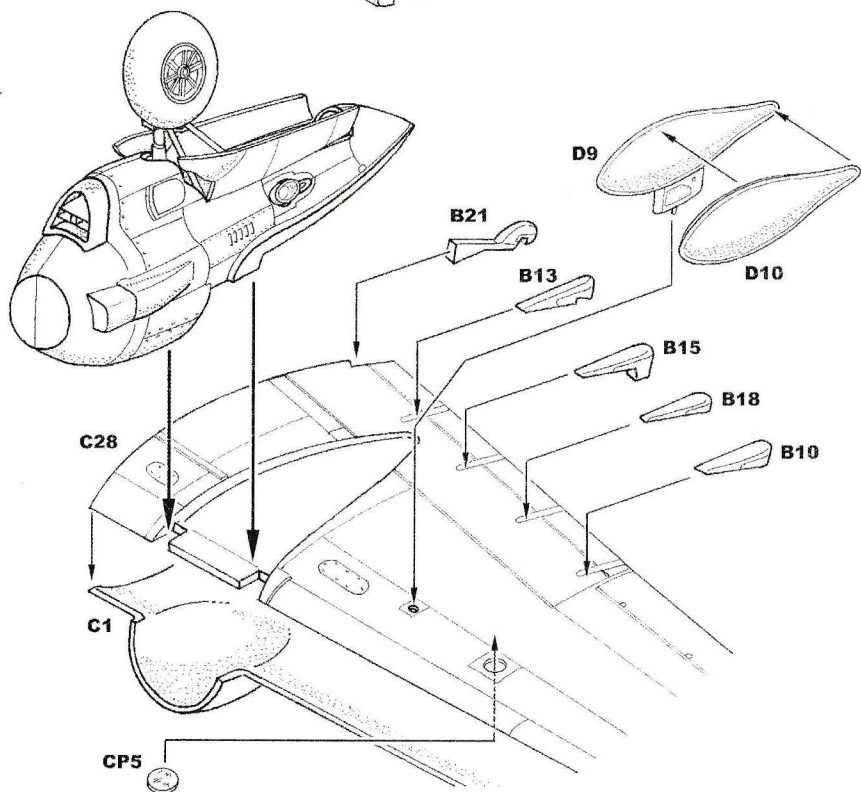

14

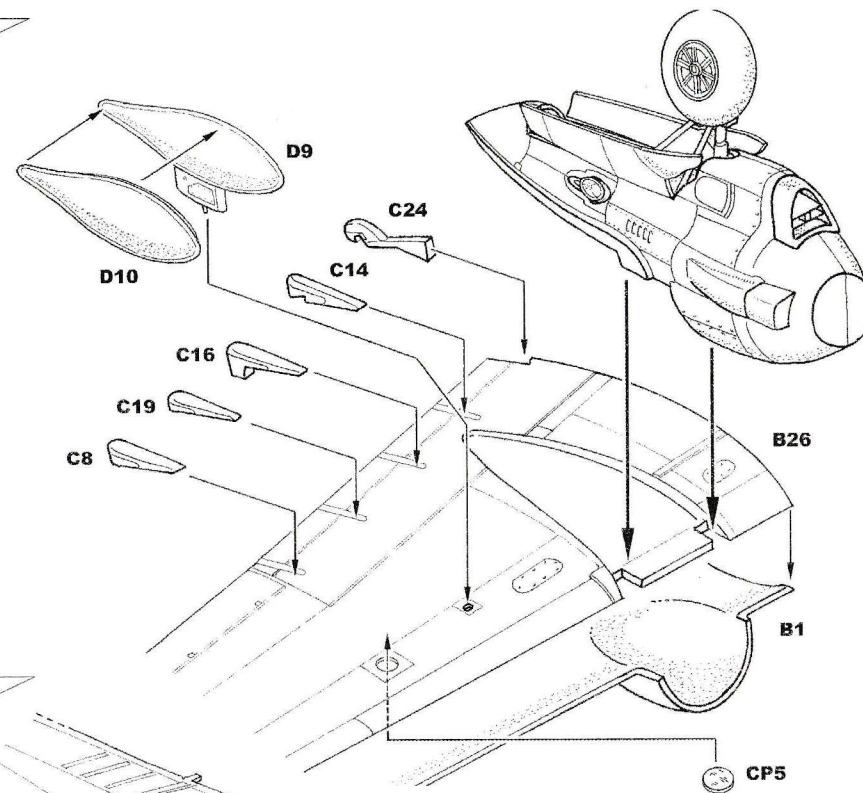

15

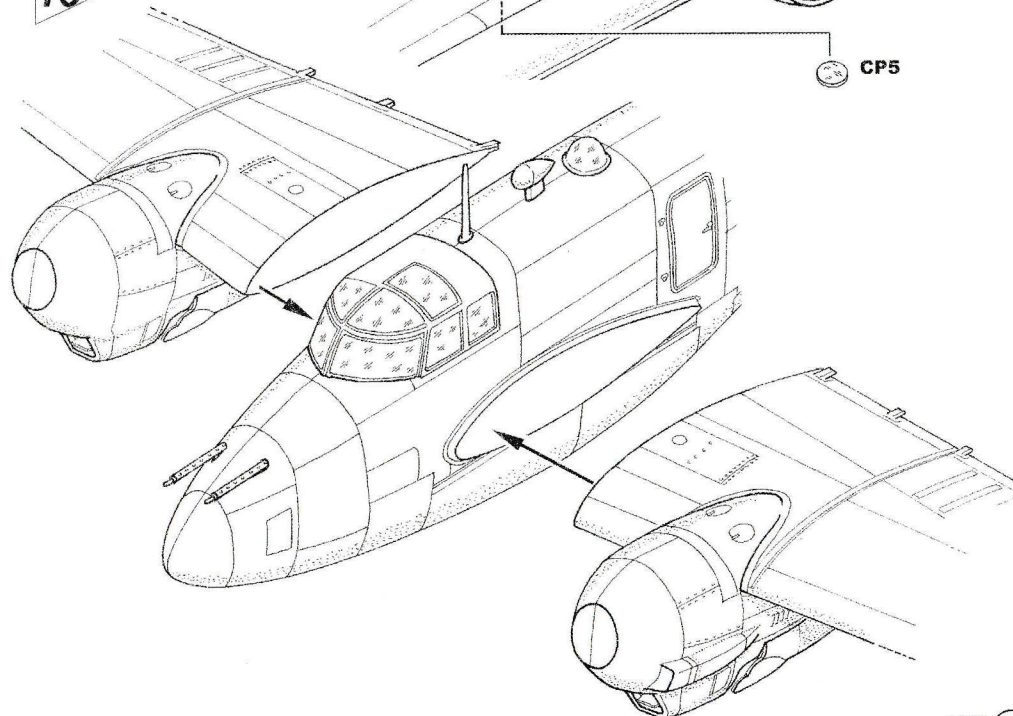

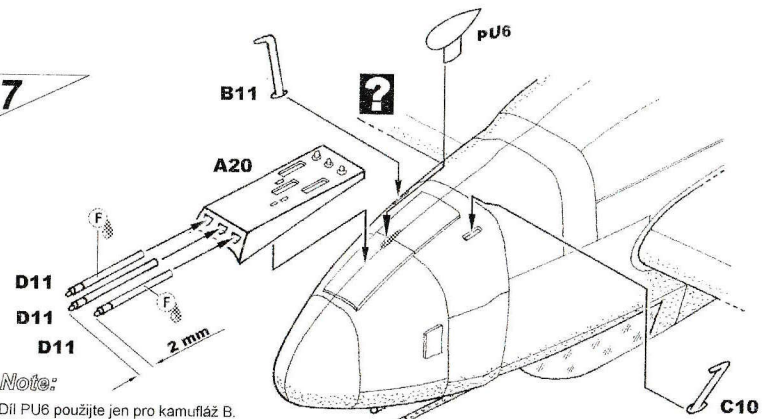
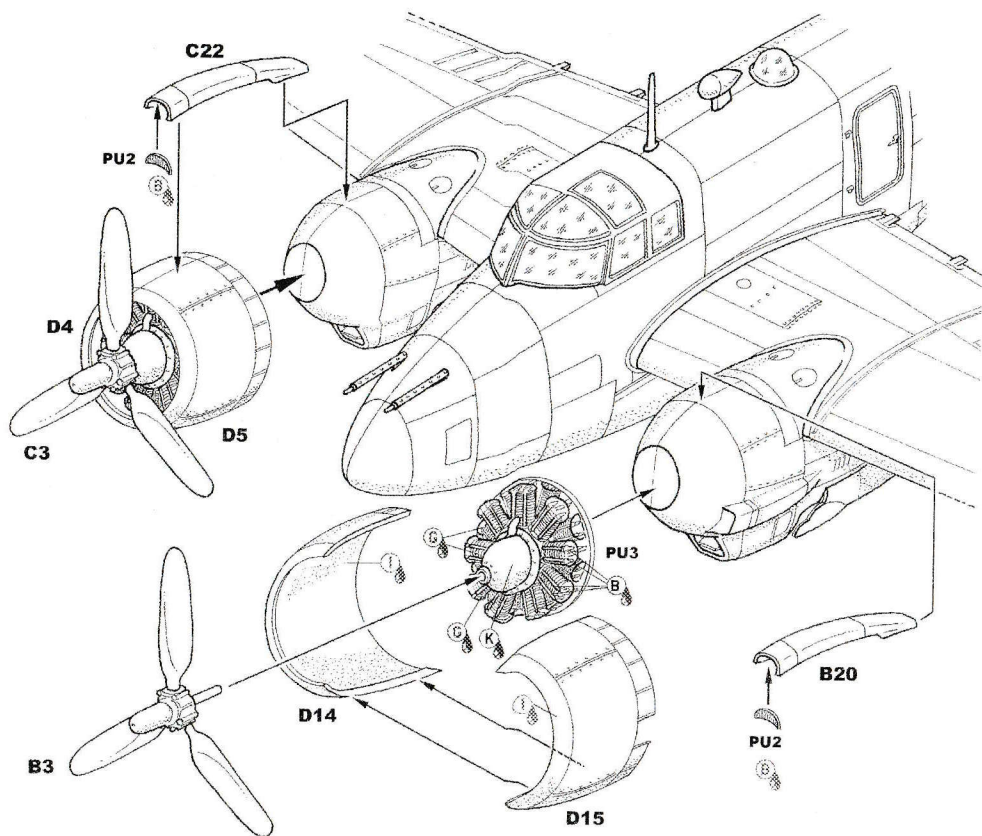

Note:
 Díl PU6 použijte jen pro kamufláž B.
 Use part PU6 only for camo B.
 Díly D11 a A20 použijte pro kamufláže A, C.
 Use parts D11 and A20 only for camo A, C.

Harpoon, 19-9, c/ino. 15-1246. 320. perúf Marine-
 artdienstu (letecké složky Nizozemského Královského
 Luchtvaaartdienst (Netherlands Royal Naval Aviation Service), 1951-53.

PV-2 Harpoon, 19-9, c/ino. 15-1246. 320. Squadron of Marine-
 Luchtvaaartdienst (Netherlands Royal Naval Aviation Service), 1951-53.

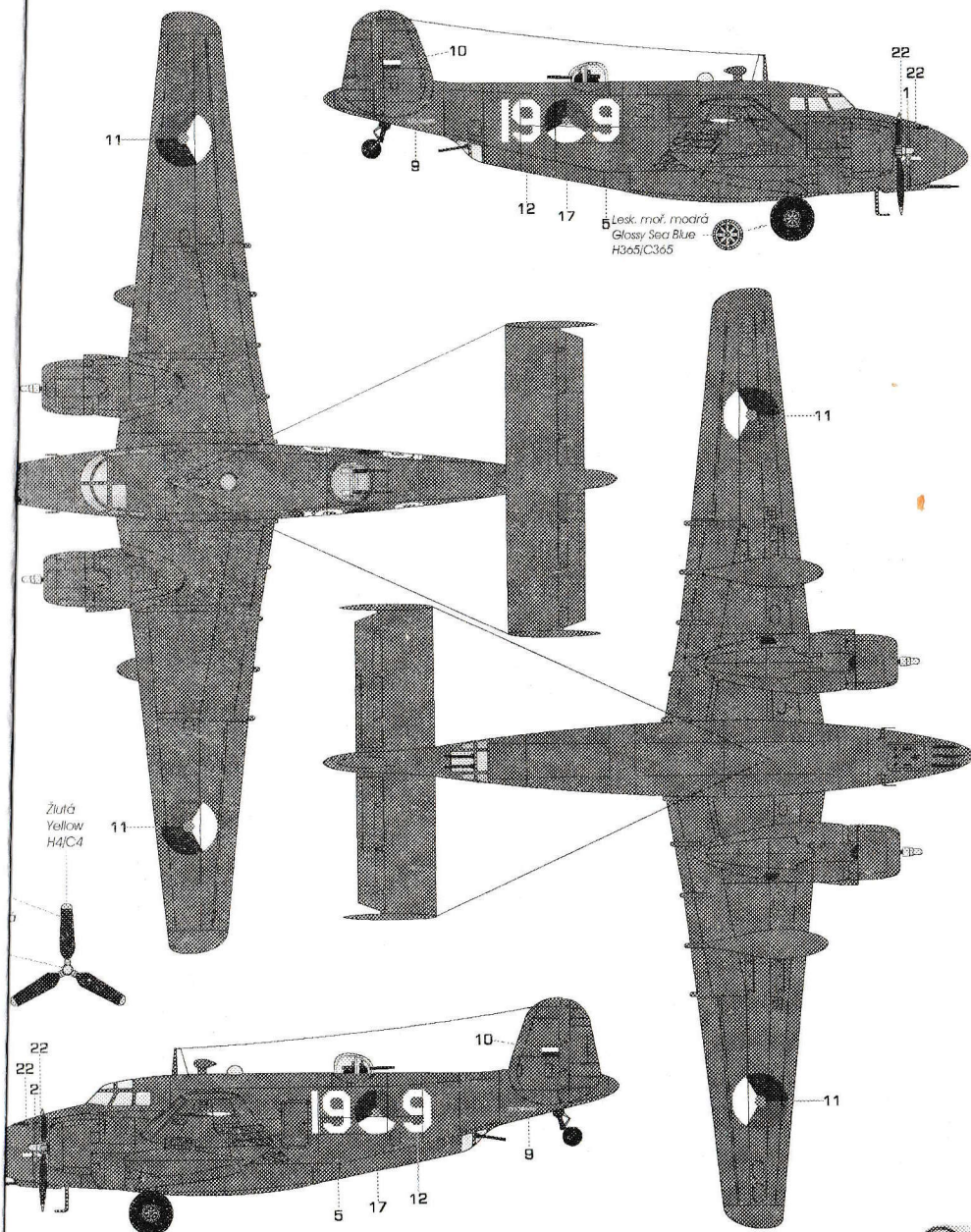

Žlutá
 Yellow
 H4/C4

Lesklá mořská modrá
 Glossy Sea Blue
 H365/C365



PV-2 Harpoon, 11.S.1, 11. Escadrille de Servitude, základna Alžír - Maison Blanche, 1953. Tento Harpoon byl upraven pro transportní účely sejmufim výzbroje, radaru a montáží oken do trupu.

PV-2 Harpoon, 11.S.1, 11. Escadrille de Servitude, Alger - Maison Blanche airbase, 1953. This machine was modified for transport purposes. The armament was stripped off and additional windows were added to fuselage.

PV-2 Harpoon, 446, c/n. 1412, 2º Grupo de Bombardeio Medio, FAB (Brazilské vojenské letectvo), 1947.

PV-2 Harpoon, 446, c/n. 1412, 2º Grupo de Bombardeio Medio, FAB (Brazilian Air Force), 1947.

CAM. B

CAM. B

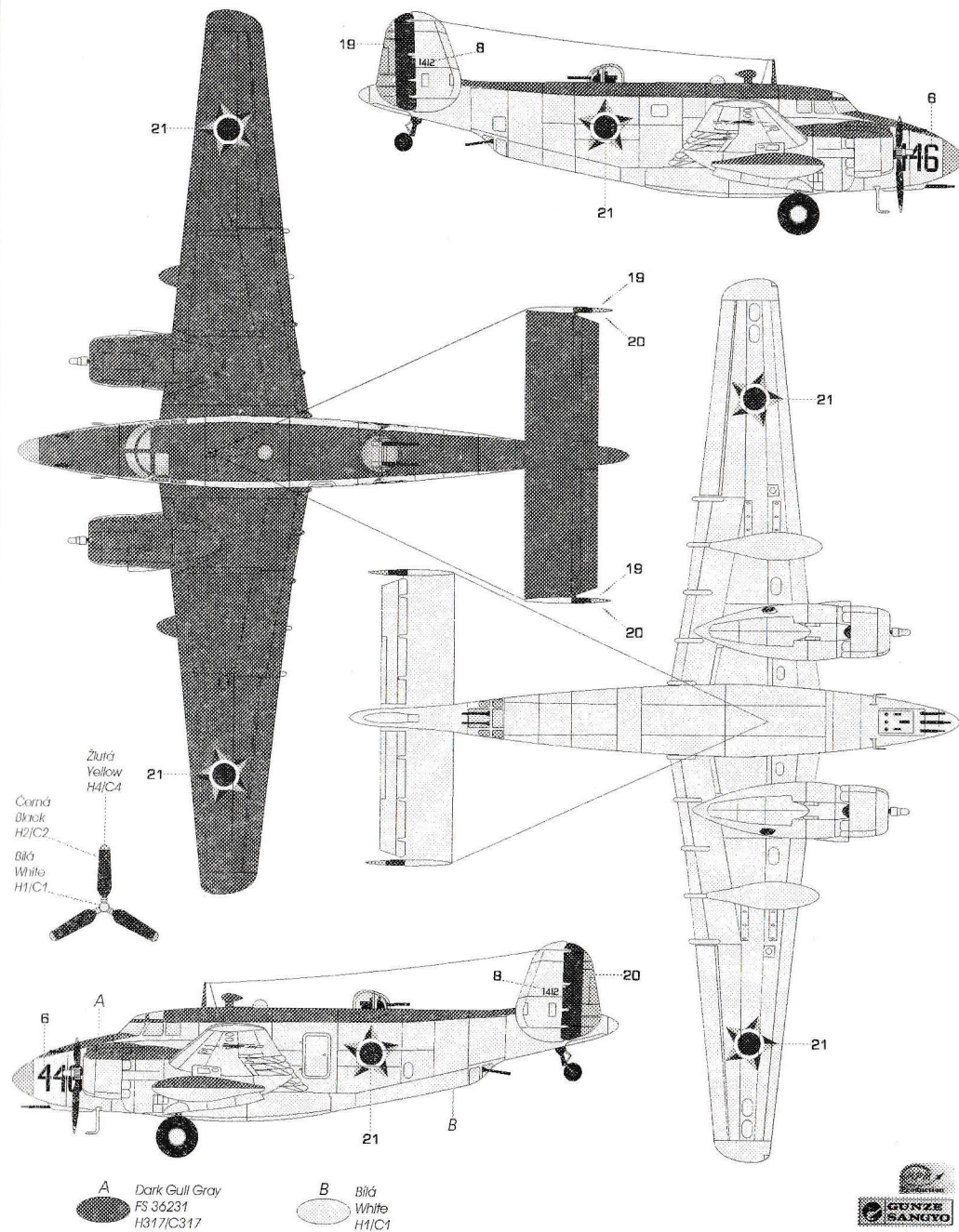
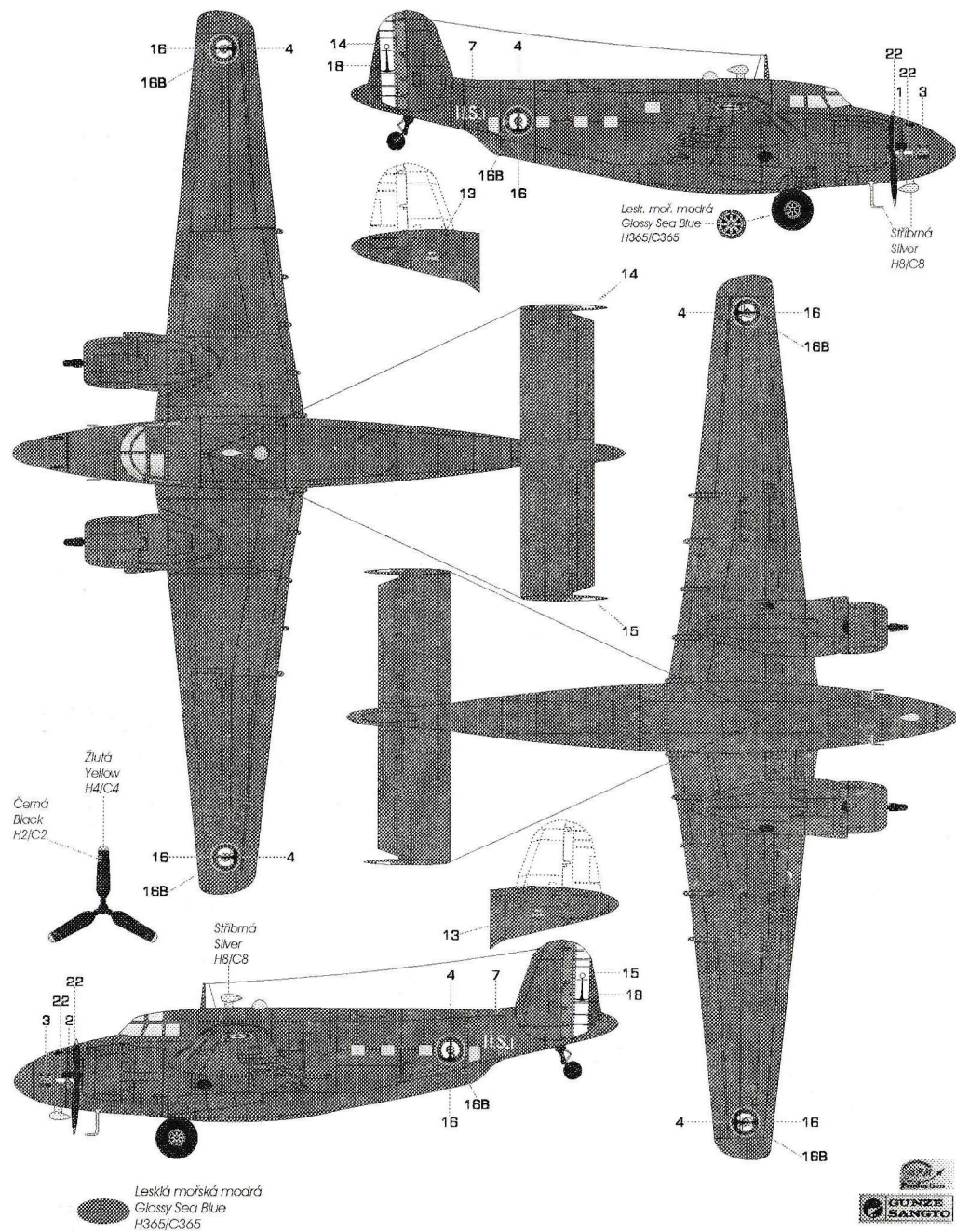

2010/12

SH72213 PV-2 Harpoon



2010/12

SH72213 PV-2 Harpoon