

**DeHavilland Vampire FB.5, WA163/G** of No.71(Eagle) Sqn., RAF Gutersloh, Germany in August 1951.  
Flown by the CO, Sqn. Ldr. Hardy. (Ref: File - loose photo; RLW MD101).

**Note:** Use kit markings where appropriate.

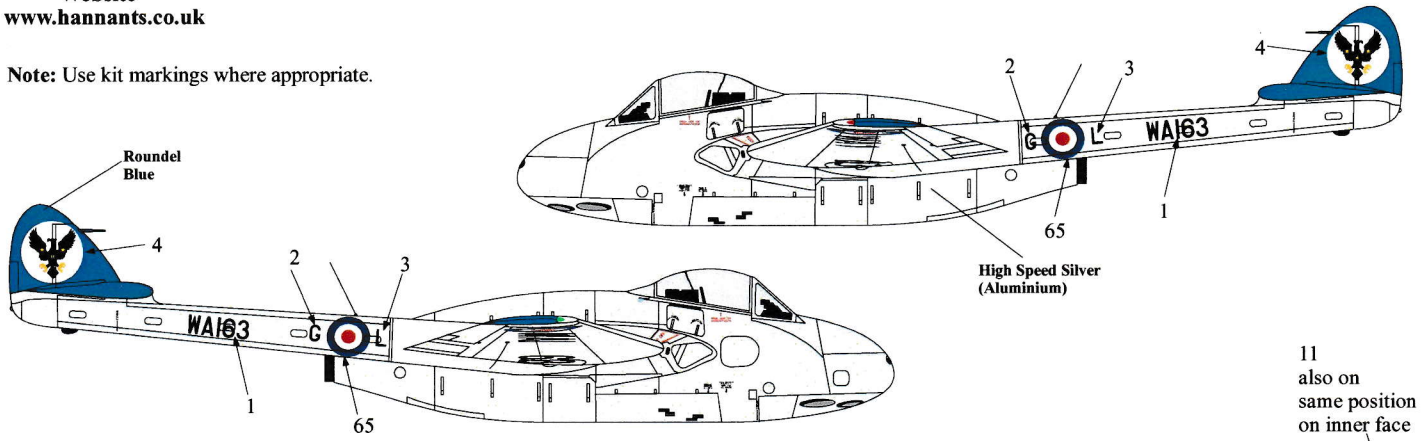

**DeHavilland Vampire FB.5, WA402/J** of No. 612 (County of Aberdeen) Sqn., RAuxAF, Dyce circa 1956.  
(Ref: RLW MD101; Alan Carlaw - 612 colours ).

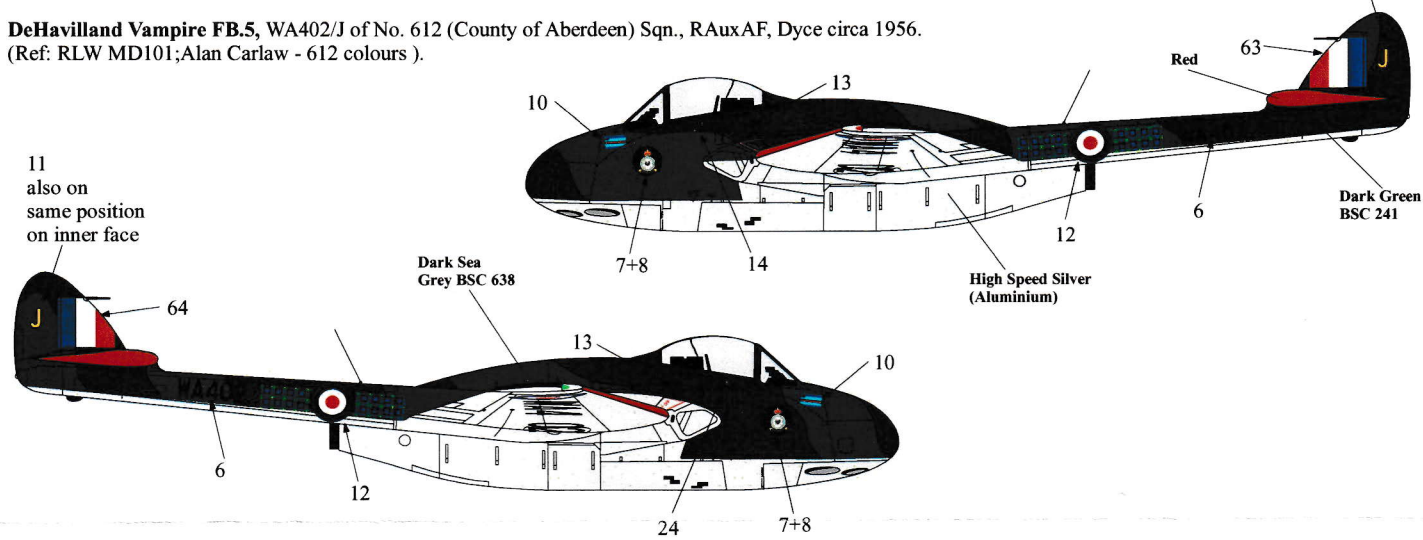

**DeHavilland Vampire FB.5, WA419/E**; WAS, flown by OC RAF Ouston, with the markings of the resident RAuxAF Squadrons, Nos 607 and 608 on the port and starboard booms respectively.  
(Ref: R.Lindsay photos: MilAvReview Oct 76 P.10 ).

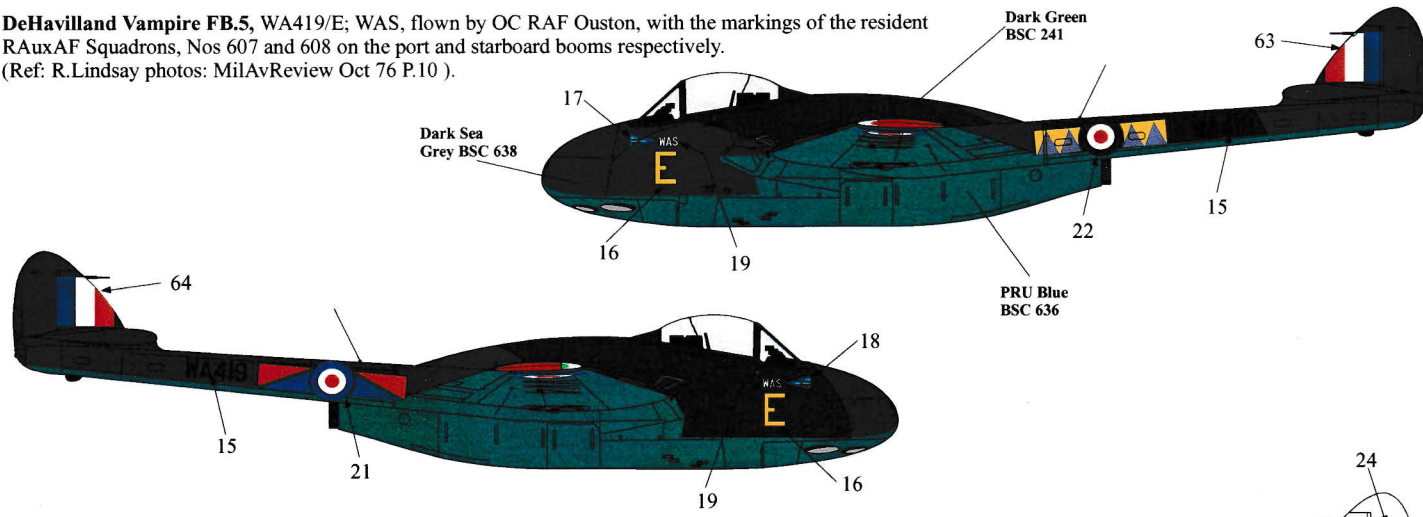

**DeHavilland Vampire FB.9, WL555/E** of No. 60 Sqn., RAF Tengah, Singapore,  
Far East Air Force, circa 1953.  
(Ref: RLW MD101).

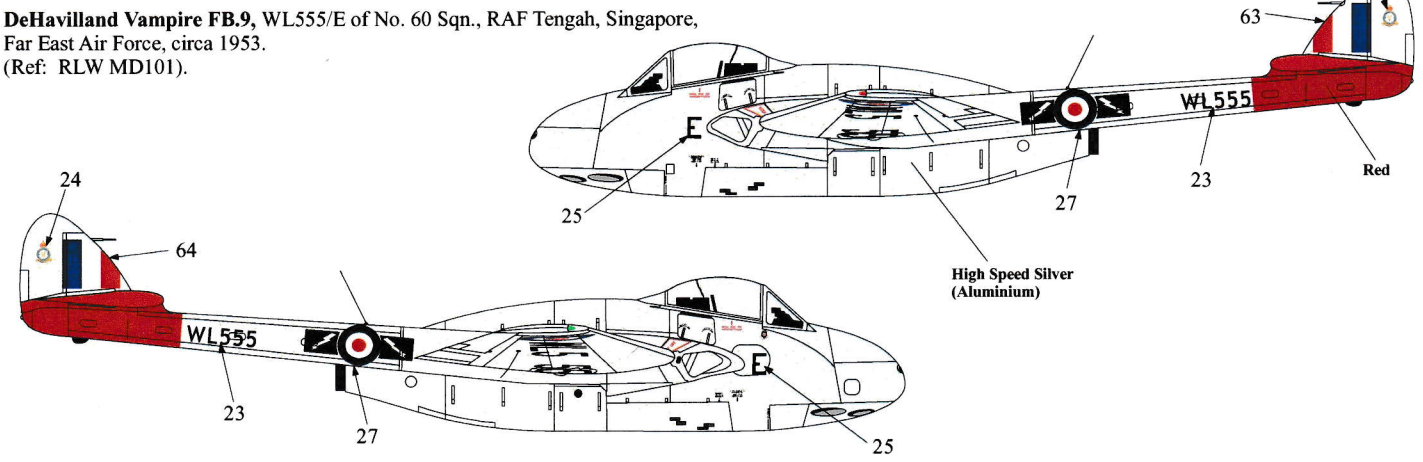

**DeHavilland Vampire FB.9, WL559/P of No.8 Sqn., RAF Khormaksar, Aden, circa 1956.**  
 (Ref: RLW Photo).

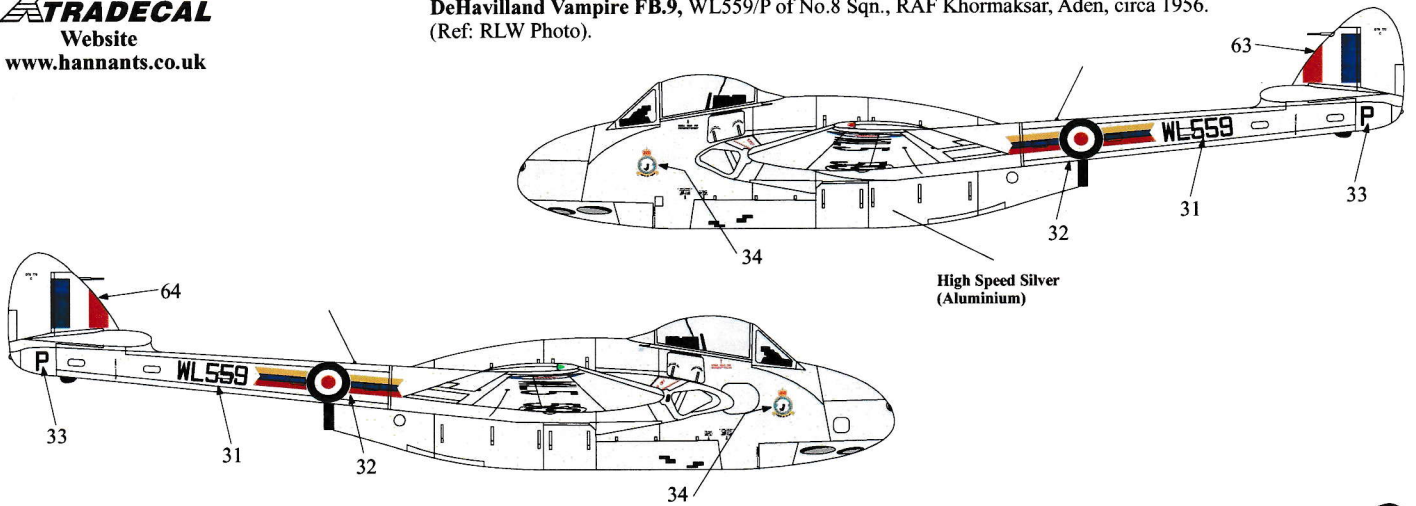

**DeHavilland Vampire FB.9, WP990/A of No.28 Sqn., RAF Kai Tak, Hong Kong, FEAF in late 1955.**  
 (Ref: RLW Photo ).

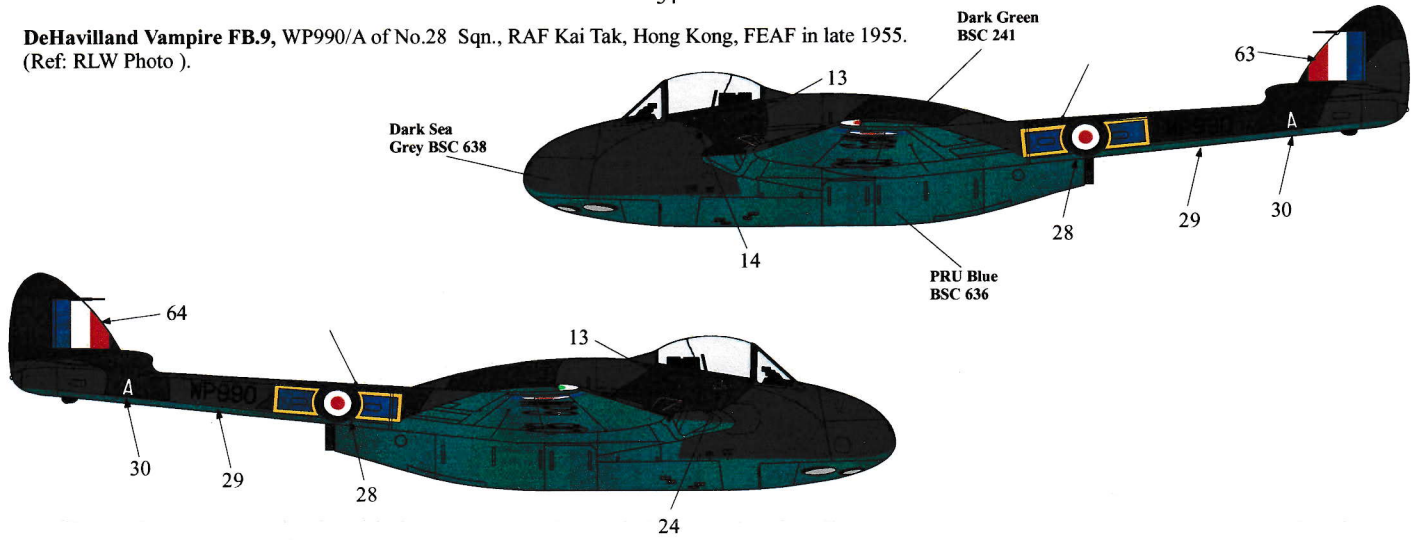

**DeHavilland Vampire FB.9, WR120/U of No.213 Sqn., RAF Deversoir, Egypt in 1954.**  
 (Ref: R.Lindsay photo; RLW MD 101 ).

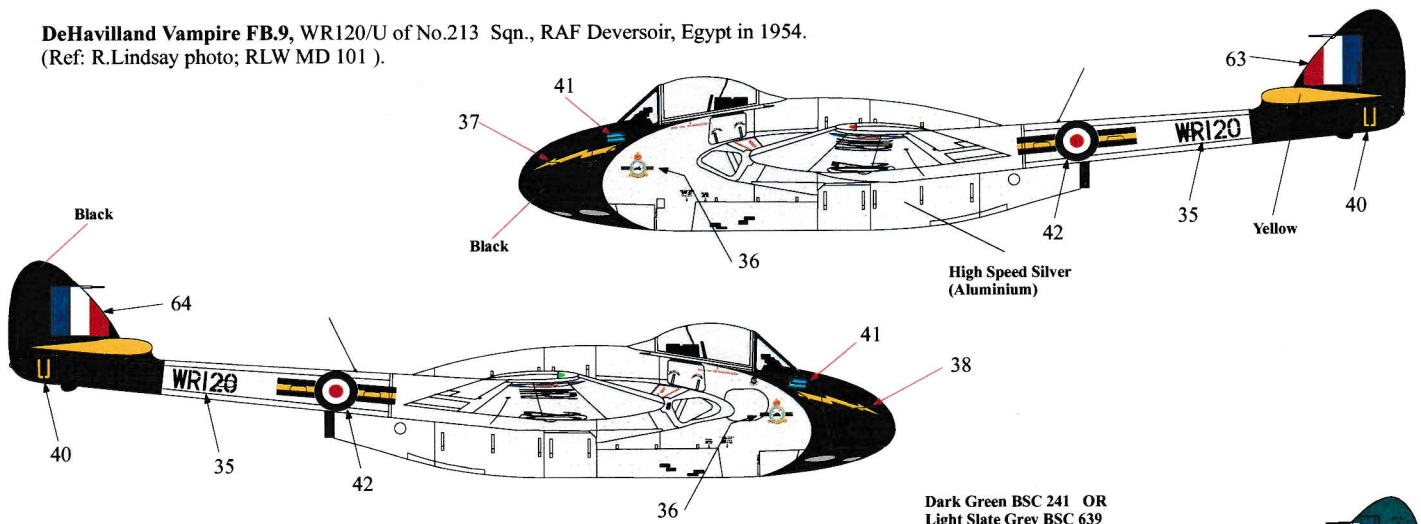

**DeHavilland Vampire FB.9, WX207/F of No.213 Sqn., RAF Dersoir, Egypt, circa 1955.**  
 (Ref: Take Off No.98, 1994 - cover photo in colour).

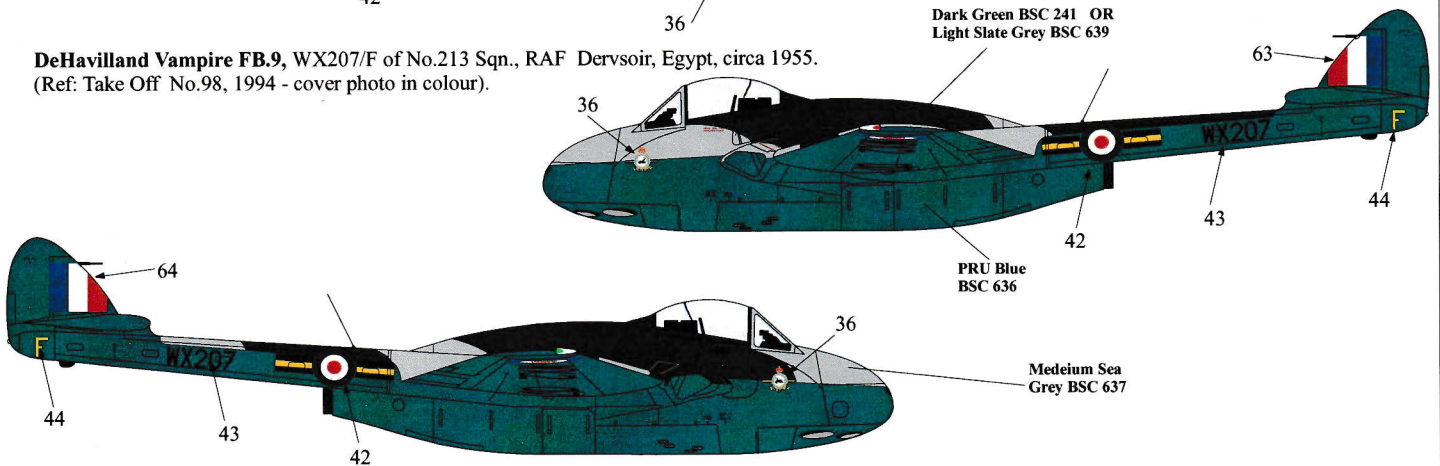

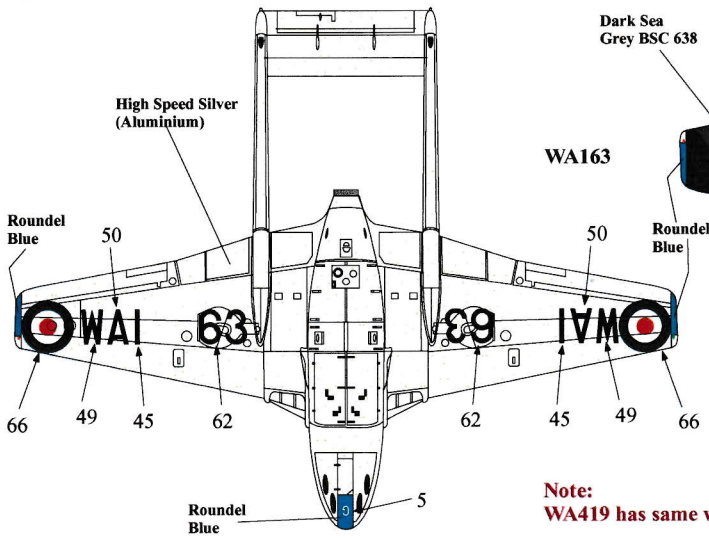

WA163

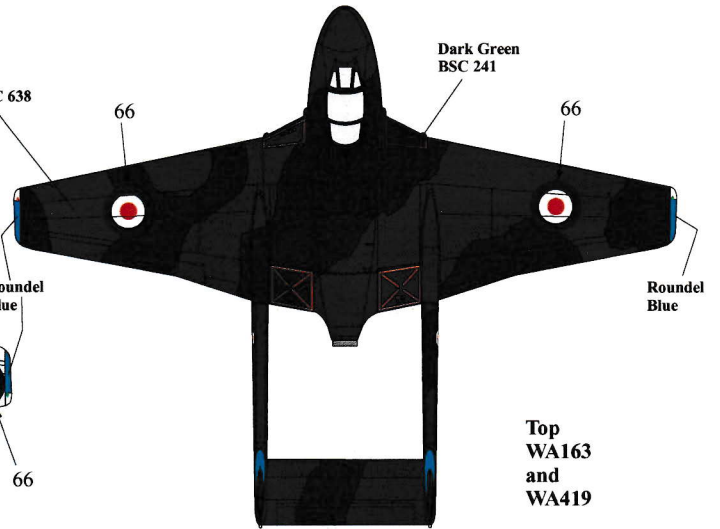

Top  
WA163  
and  
WA419

**Note:**  
 WA419 has same wing tips in red.

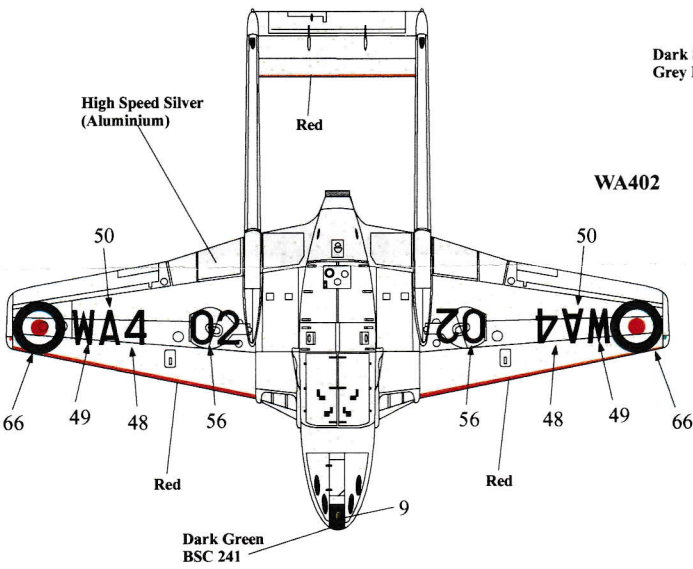

WA402

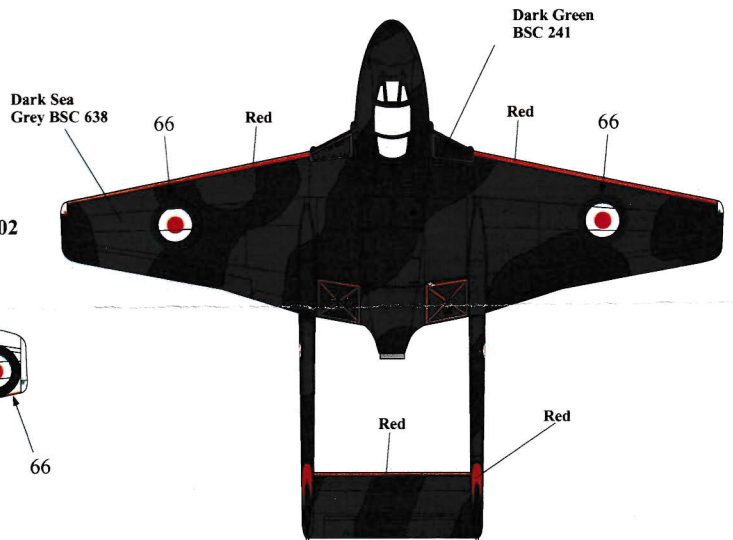

**Bot**  
 WL555 NWD Silver, Black "E", red rear booms.  
 WL559, NWD Silver, Black "P".

**Top**  
 WL555 NWD Silver, Black "E", red rear booms.  
 WL559, NWD Silver, Black "E".

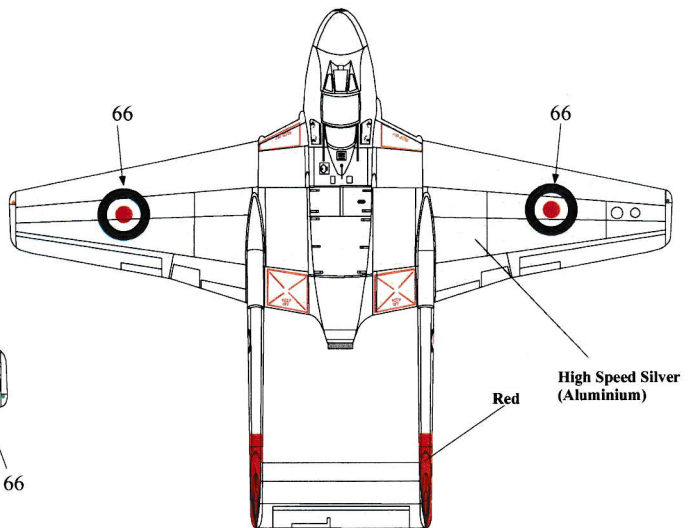
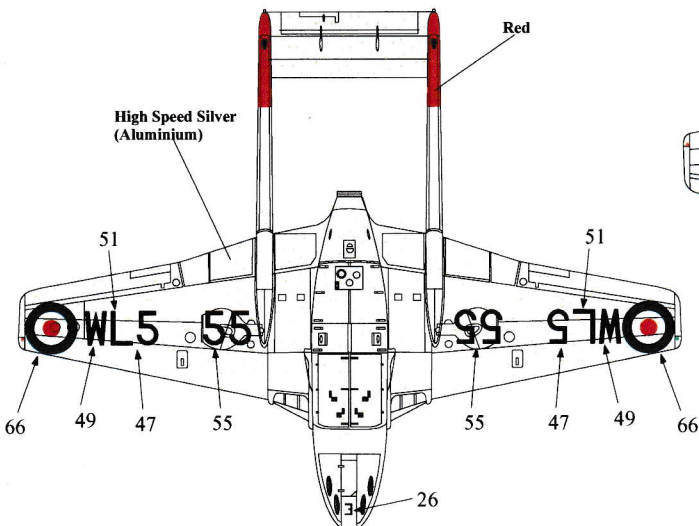

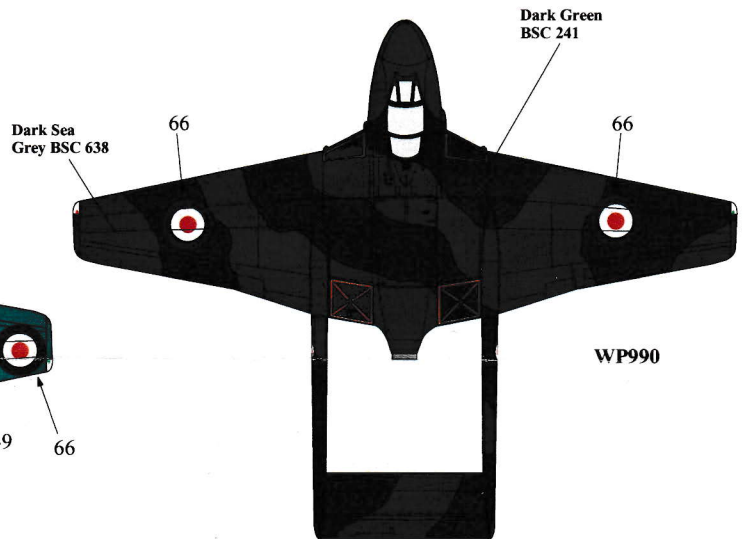
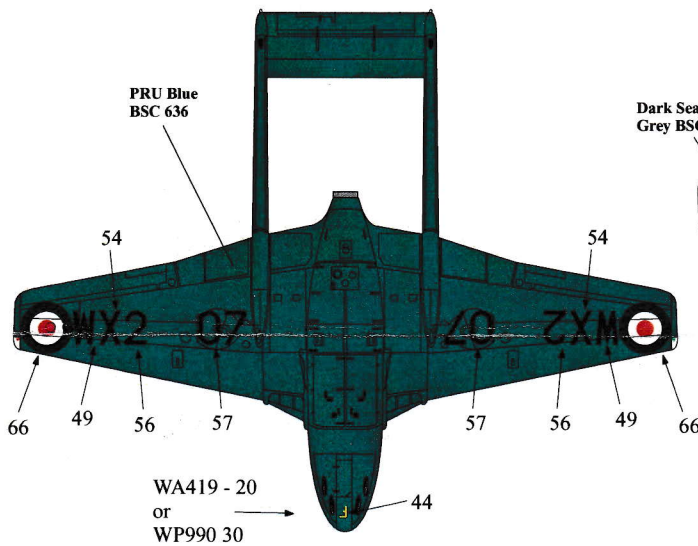
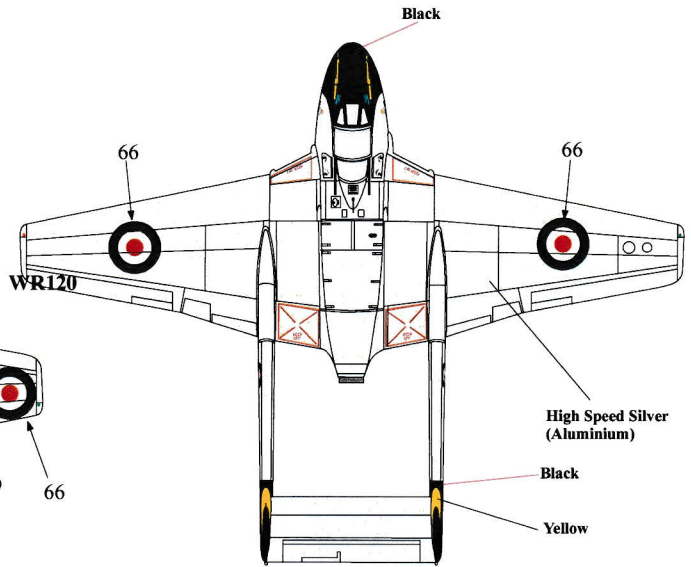
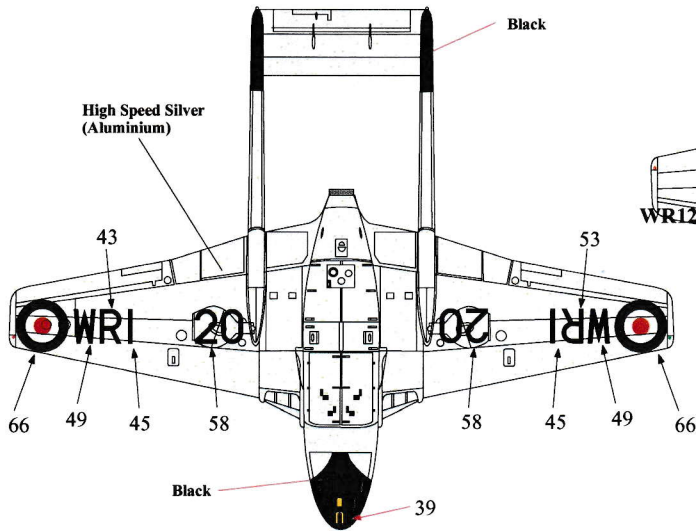

WA419 NWD Blue, Yellow "E", Red wing tips (As on WA163)  
 WX207 NWD Green, Yellow "F"  
 WP990 NWD Blue, White "A"

**WX207 Camouflage colours:**

Whilst the Med Sea Grey and PRU Blue are clearly identifiable, the contrast colour is not. If the scheme conforms to that of some early Canberras and PR Meteors, the colour is Light Slate Grey, however, the photograph on which the image is based suggests that Dark Green is the colour used, however, that has to be balanced against a possible bias in printing. It is the Modellers choice!

**Undercarriage Doors/Serials**

It is recommended that undercarriage doors be temporarily tacked in place, the appropriate serial applied and the outline cut through with a NEW sharp blade. The subject serials have been provided as pairs of numbers to assist the modeller.

**Xtracolor Paints:**

- Dark Green BS241 X001
- Medium Sea Grey BS637 X003
- Dark Sea Grey BS638 X004
- PRU Blue BS636 X008
- Night BS642 X012
- Roundel Blue BS110 X030
- PO Red BS538 X031
- High Speed Silver X038
- Aluminium X142

**Xtracrylix Paints:**

- Dark Green BS241
- Medium Sea Grey BS637
- Dark Sea Grey BS638
- PRU Blue BS636
- Trainer Yellow
- Night BS642
- RAF Red Arrows Red

- XA1001
- XA1003
- XA1004
- XA1008
- XA1011
- XA1012
- XA1014

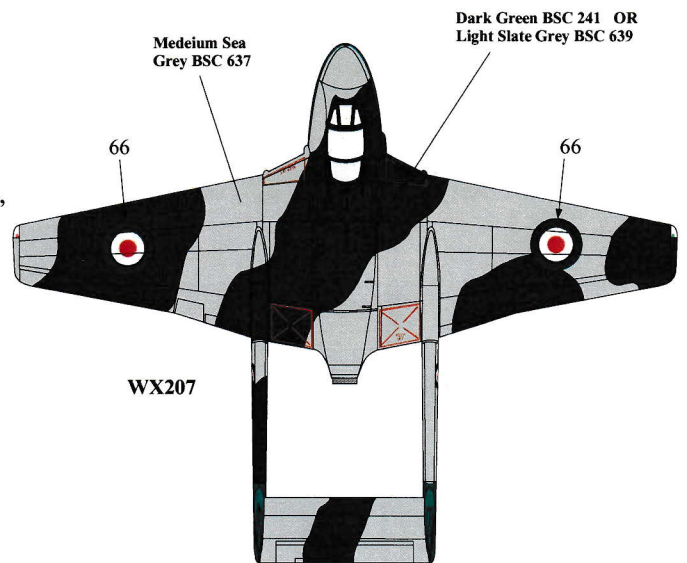

The Assistance provided by:  
**R.L.(Dick) Ward,**  
**David Watkins,**  
**Alan Carlaw**  
**Roger Lindsay**  
 is gratefully acknowledged.