

F-86 GOPHER PATROL
335th FISq
AT KIMPO SUMMER 1942

PORT SIDE ONLY
BOTH SIDES

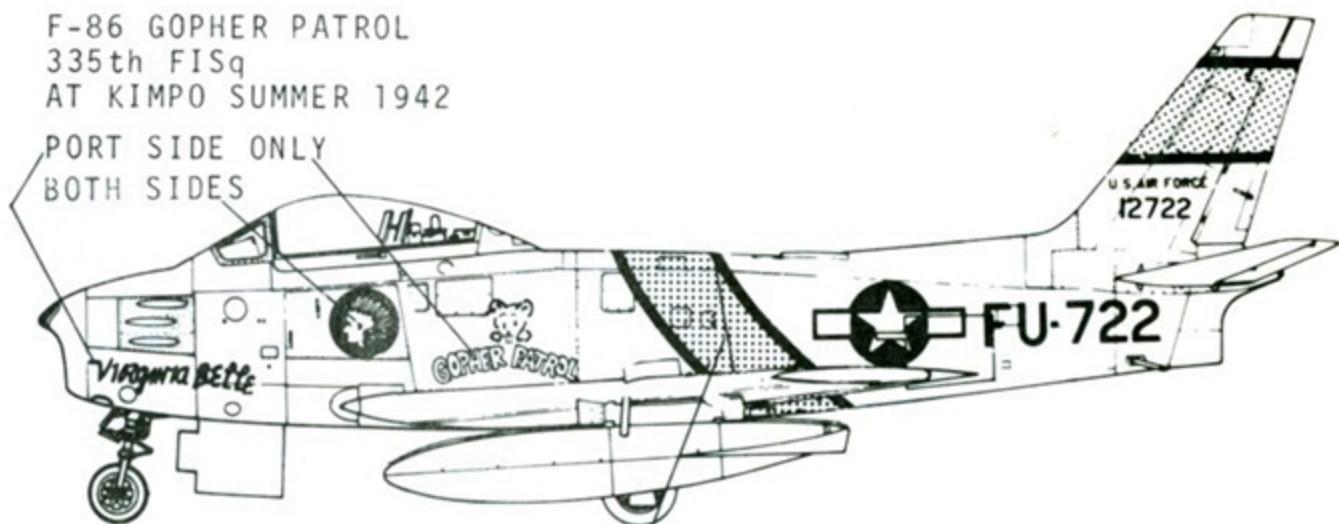

PAINT YELLOW BEFORE DECALING

F-86 WAM BAM
FLOWN BY LT. MARTIN BAMBRICK
WITH THE 336th FISq IN SUMMER 1952

PORT SIDE ONLY

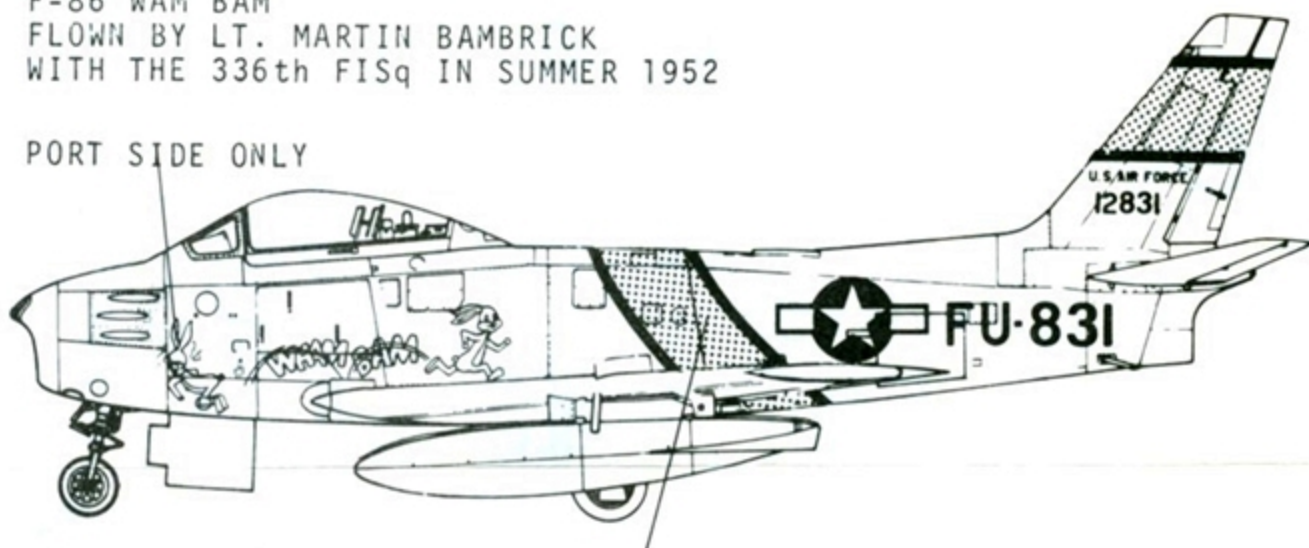

PAINT YELLOW BEFORE DECALING

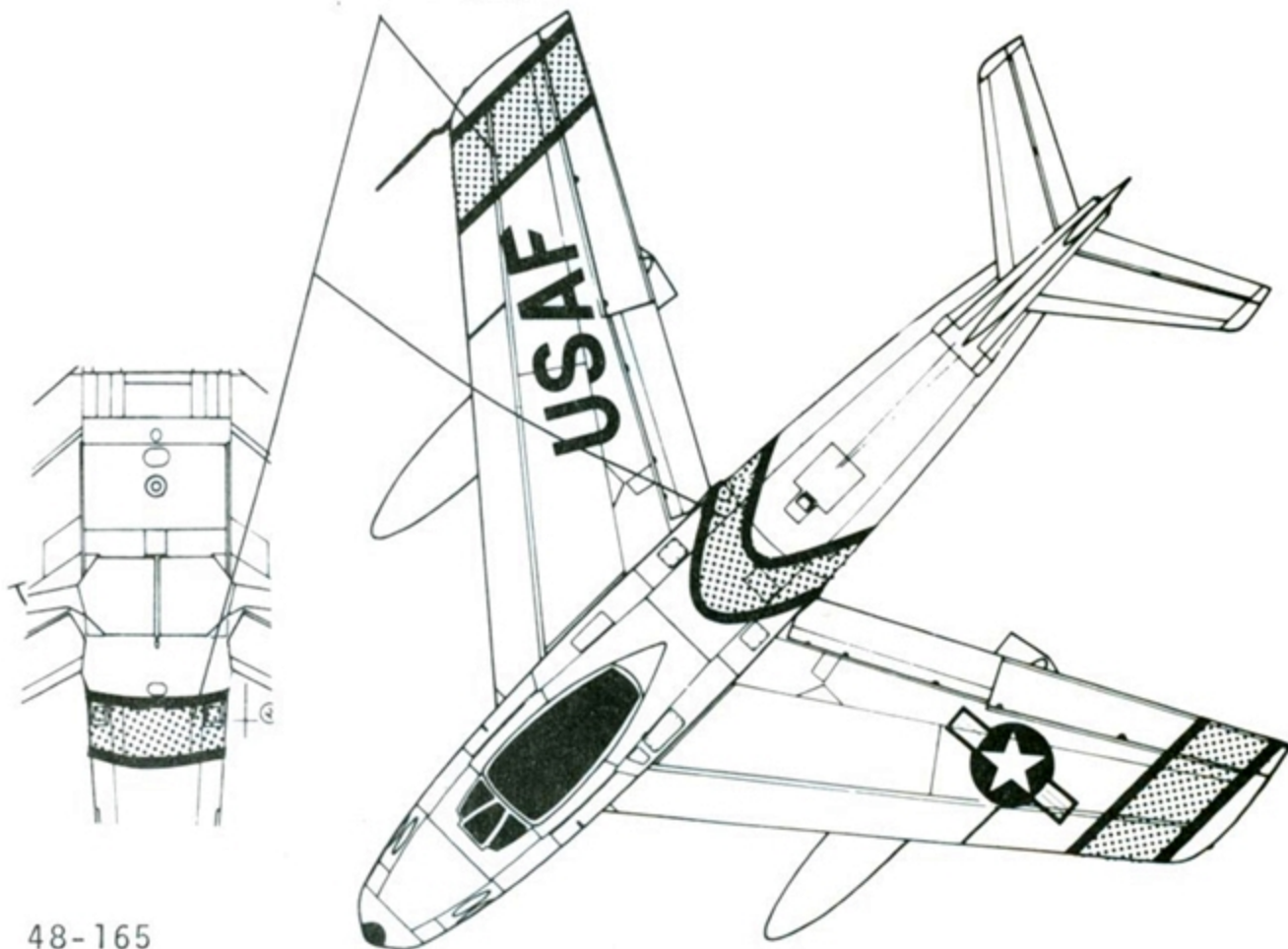

OVERALL AIRCRAFT IS NATURAL METAL ALL VERSIONS

U.S. AIR FORCE F-86F-30-NA
A.F. SERIAL NO. 12345678910
SERVICE THIS AIRPLANE WITH GRADE #4 FUEL

WARNING

THIS AIRPLANE CONTAINS A SEAT EJECTION CATAPULT CONTAINING AN EXPLOSIVE CHARGE SEE T.O. 11-1-88 FOR COMPLETE INSTRUCTIONS

WARNING

THIS AIRPLANE CONTAINS A SEAT EJECTION CATAPULT CONTAINING AN EXPLOSIVE CHARGE SEE T.O. 11-1-88 FOR COMPLETE INSTRUCTIONS



USE AN F-32 GRADE #4 FUEL
FIRST - FILL FWD FUSE & CENTER WING CELLS
SECOND - FILL OUTER WING CELLS
LAST - FILL AFT FUSE CELLS
CAUTION - DO NOT OVERFLOW

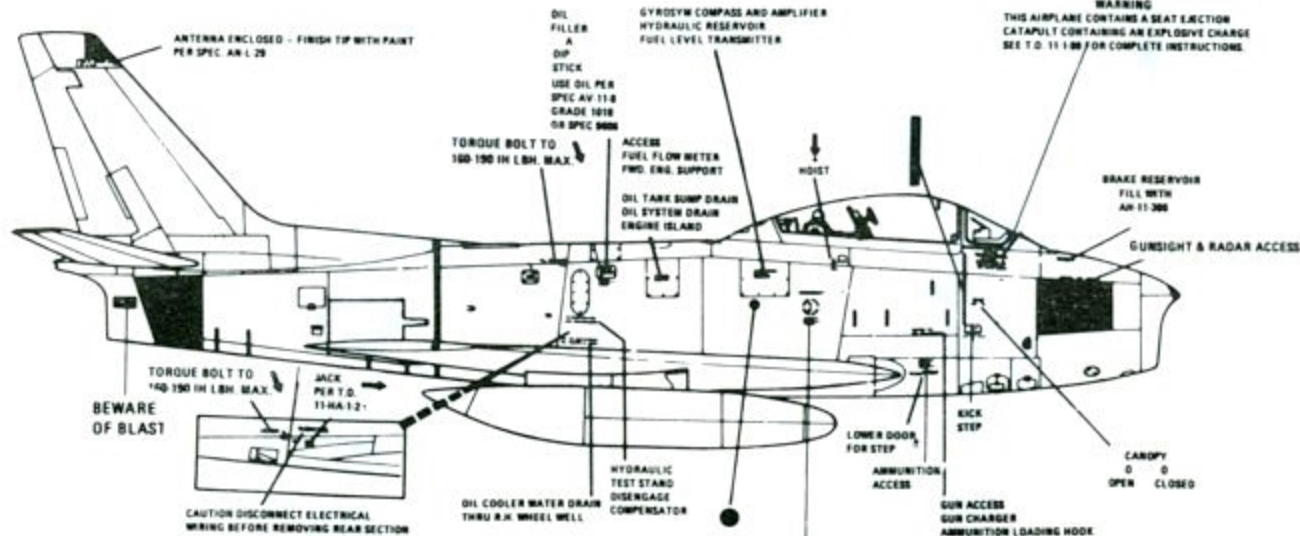
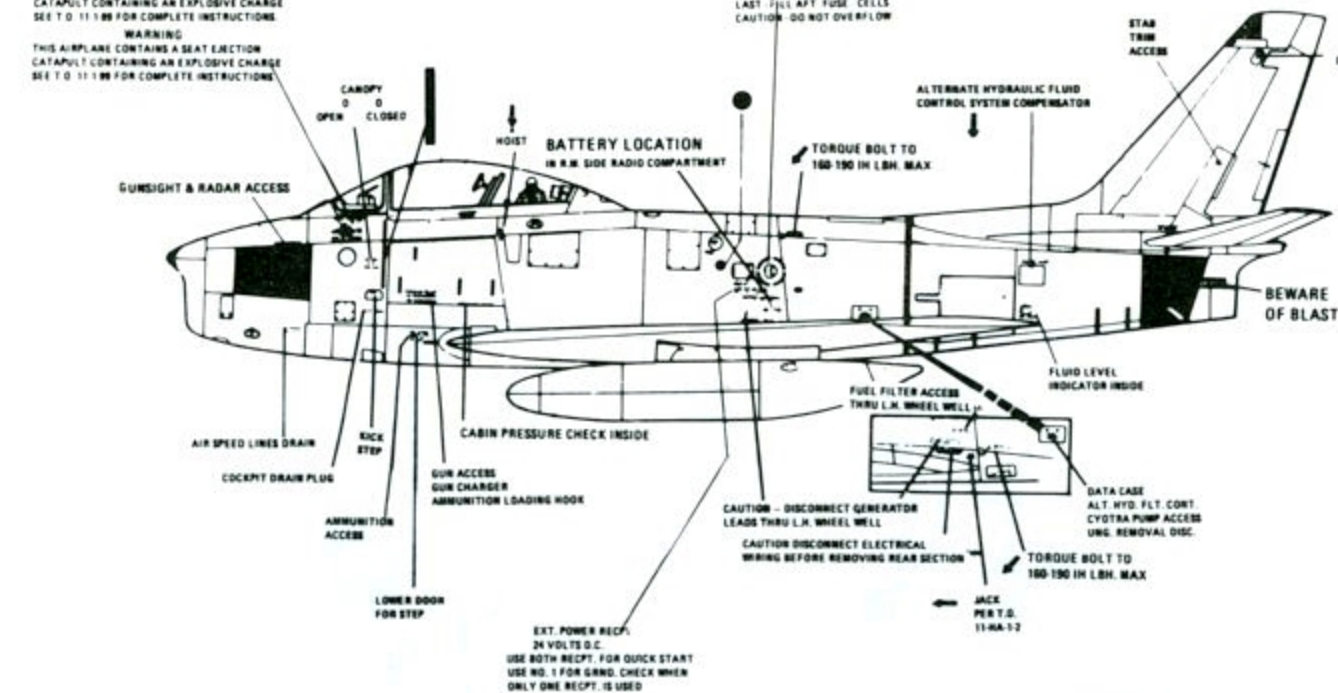

USE AN F-32 GRADE #4 FUEL
FIRST - FILL FWD FUSE & CENTER WING CELLS
SECOND - FILL OUTER WING CELLS
LAST - FILL AFT FUSE CELLS
CAUTION - DO NOT OVERFLOW

WARNING
THIS AIRPLANE CONTAINS A SEAT EJECTION CATAPULT CONTAINING AN EXPLOSIVE CHARGE SEE T.O. 11-1-88 FOR COMPLETE INSTRUCTIONS

WARNING
THIS AIRPLANE CONTAINS A SEAT EJECTION CATAPULT CONTAINING AN EXPLOSIVE CHARGE SEE T.O. 11-1-88 FOR COMPLETE INSTRUCTIONS

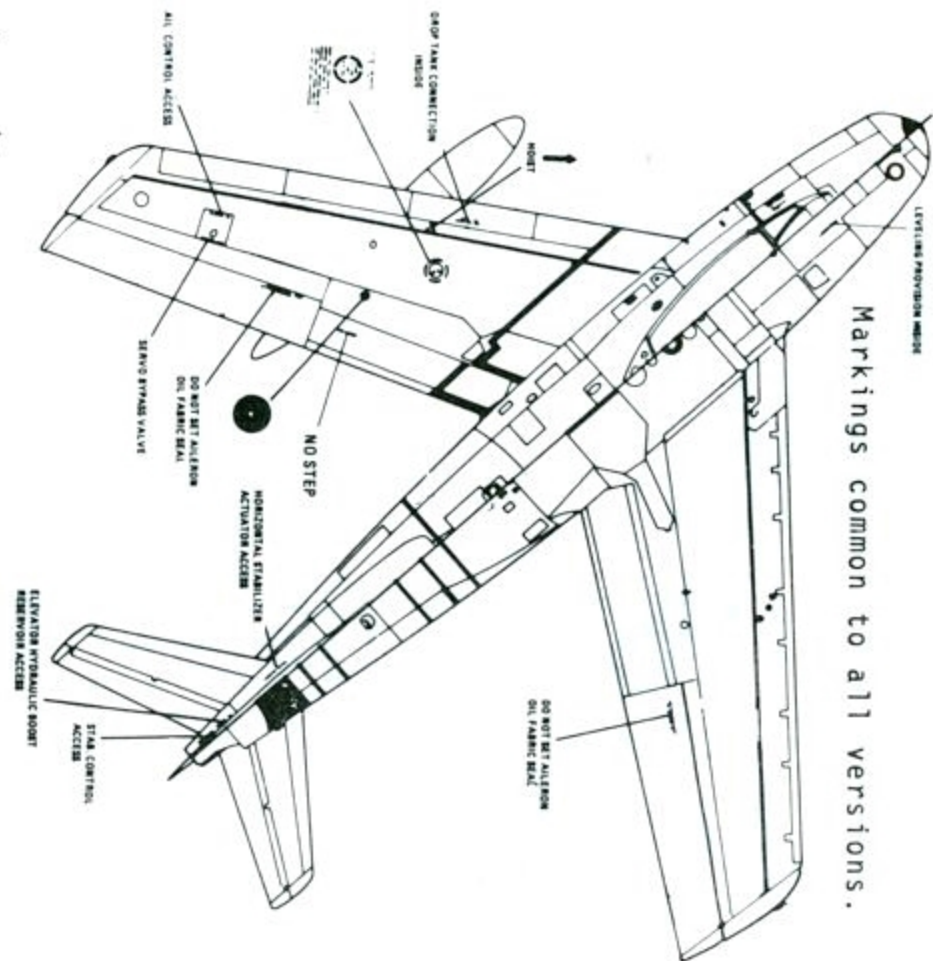

Markings common to all versions.